

DRUM MOTOR

DL SERIES

DL 0113



A lightweight motor for light-duty applications. The DL 0113 is a cost-efficient belt drive for small to medium, dynamic belt conveyor applications and is ideal for small infeed conveyors, packaging equipment, and transfer conveyors. Its application range stretches from classic conveying applications in the dry logistics area up to applications in food production in dry to humid environments with occasional cleaning.

The proven and nearly maintenance-free design, as well as a planetary gear box made of technopolymer result in a lightweight, low-noise and at the same time powerful drum motor for applications for which the weight of the belt drive plays a role. Lightweight, friction-driven conveyor belts with a moderate belt expansion factor are particularly well suited for use with a DL 0113 drum motor.

The speed of the DL 0113 with three-phase motor winding can be adjusted by means of a frequency inverter. In addition to the three-phase motor variant, the DL 0113 is also available with a single-phase motor winding. This also allows operating the drum motor directly on a single-phase network, such as a grounded household power outlet, without additional power electronics.



Technical data

	Asynchronous squirrel cage motor, IEC 34 (VDE 0530)
Insulation class of motor windings	Class F, IEC 34 (VDE 0530)
Voltage	230/400 V \pm 5 % (IEC 34/38)
Frequency	50 Hz
Shaft seal, internal	NBR
Shaft seal, external	Deflection seal, NBR
Protection rate	IP66 (with grease nipple)
Thermal protection	Bi-metal switch
Operating mode	S1
Ambient temperature, 3-phase motor	+5 to +40 °C Low temperature ranges on request
Ambient temperature, 1-phase motor	+5 to +40 °C

Design variants and accessories

Lagging	Lagging for friction drive belts
Oils	Food-grade oils (EU, FDA)
Certificate	cULus safety certificates
Accessories	Idler pulleys; conveyor rollers; mounting brackets; cables; inverters

DRUM MOTOR

DL SERIES

DL 0113

Material variants

Component	Version	Aluminum	Mild steel	Stainless steel	Brass/nickel	Technopolymer
Shell	Crowned		●	●		
	Cylindrical		●	●		
End housing	Standard	●		●		
Shaft cap	Standard	●				
	With cable protection	●				
	Regreasable			●		
Gear boxes	Planetary gear box					●
Electrical connector	Straight connector			●	●	
	Elbow connector			●		
	Terminal box	●		●		
Motor winding	Asynchronous motor					
External seal	NBR					

DRUM MOTOR DL SERIES DL 0113

Motor variants

Mechanical data for 3-phase asynchronous motor

P_N [W]	n_p	gs	i	v [m/s]	n_A [min ⁻¹]	M_A [Nm]	F_N [N]	FW_{MIN} [mm]	SL_{MIN} [mm]
40	8	3	63.00	0.068	11.4	28.6	505	282	260
40	8	3	49.29	0.087	14.6	22.4	395	282	260
40	8	3	38.51	38.51	0.111	18.7	17.5	331	309
110	4	3	63.00	0.129	21.7	41.6	734	262	240
110	4	3	49.29	0.164	27.7	32.5	574	262	240
110	4	3	44.09	0.184	31.0	29.1	514	262	240
110	4	3	38.51	0.210	35.4	25.4	449	262	240
110	4	3	30.77	0.263	44.4	20.3	359	262	240
110	4	3	26.84	0.302	50.9	17.7	313	262	240
110	4	3	23.96	0.338	57.0	15.8	279	262	240
110	4	2	15.00	0.540	91.0	10.4	184	262	240
110	4	2	11.57	0.700	118.0	8.0	142	262	240
110	4	2	10.27	0.788	132.9	7.1	126	262	240
110	4	2	8.88	0.912	153.8	6.2	109	262	240
110	4	2	7.86	1.031	173.7	5.5	96	262	240
160	4	3	44.09	0.182	30.6	42.7	754	282	260
180	4	3	38.51	0.209	35.2	41.9	470	297	275
180	4	3	30.77	0.261	44.0	33.5	591	297	275
180	4	3	26.84	0.300	50.5	29.2	516	297	275
180	4	3	23.96	0.335	56.6	26.1	461	297	275
180	4	2	15.00	0.536	90.3	17.2	303	297	275
180	4	2	11.57	0.695	117.1	13.3	234	297	275
180	4	2	10.27	0.782	131.9	11.8	208	297	275
180	4	2	8.88	0.905	152.6	10.2	180	297	275
180	4	2	7.86	1.023	172.5	9.0	159	297	275

DRUM MOTOR

DL SERIES

DL 0113

P_N [W]	n_p	gs	i	v [m/s]	n_A [min ⁻¹]	M_A [Nm]	F_N [N]	FW_{MIN} [mm]	SL_{MIN} [mm]
330	2	3	44.09	0.377	63.5	42.7	754	297	275
330	2	3	38.51	0.431	72.7	37.3	659	297	275
330	2	3	30.77	0.540	91.0	29.8	526	297	275
330	2	3	26.84	0.619	104.3	26.0	459	297	275
330	2	3	23.96	0.693	116.9	23.2	410	297	275
330	2	2	15.00	1.107	186.7	15.3	270	297	275

P_N	= Rated power	n_A	= Shell rated speed
n_p	= Number of poles	M_A	= Drum motor rated torque
gs	= Gear stages	F_N	= Drum motor rated belt pull
i	= Speed ratio	FW_{MIN}	= Minimum drum width
v	= Speed	SL_{MIN}	= Minimum shell length

Electrical data for 3-phase asynchronous motor

P_N [W]	n_p	n_N [min ⁻¹]	f_N [Hz]	U_N [V]	I_N [A]	cos φ	η [%]	J_R [kgcm ²]	I_s/I_N	M_s/M_N	M_B/M_N	M_P/M_N	M_N [Nm]	R_M [Ω]	$U_{SH\Delta}$ [V]	U_{SHY} [V]
40	8	720	50	230	0.64	0.58	0.27	3.9	1.53	1.59	1.59	1.49	0.53	187.5	35	–
40	8	720	50	400	0.37	0.58	0.27	3.9	1.53	1.59	1.59	1.49	0.53	187.5	–	60
110	4	1365	50	230	0.8	0.73	0.47	2.3	3.65	3.38	3.39	3.38	0.77	84	25	–
110	6	865	50	400	0.62	0.62	0.41	4	2.03	3.14	3.35	3.14	1.21	92	–	53
110	4	1365	50	400	0.45	0.75	0.47	2.3	3.64	3.41	3.42	3.41	0.77	84	–	43
160	4	1350	50	230	0.98	0.76	0.54	3.3	4.02	3.22	3.33	3.22	1.13	59.2	22	–
160	4	1350	50	400	0.57	0.75	0.54	3.3	3.98	3.25	3.35	3.25	1.13	59.2	–	38
180	4	1355	50	230	1	0.77	0.59	4	4.37	3.54	3.74	3.54	1.27	45.5	18	–
180	4	1355	50	400	0.62	0.76	0.55	4	4.42	3.6	3.79	3.6	1.27	45.5	–	32
330	2	2800	50	230	1.74	0.76	0.68	3.3	4.5	3.57	3.57	2.62	1.13	21.5	14	–
330	2	2800	50	400	0.93	0.76	0.68	3.3	4.5	3.57	3.57	2.62	1.13	21.5	–	23

P_N	= Rated power	I_s/I_N	= Ratio of startup current – rated current
n_p	= Number of poles	M_s/M_N	= Ratio of startup torque – rated torque
n_N	= Rated speed of rotor	M_B/M_N	= Ratio of pull-out torque – rated torque
f_N	= Rated frequency	M_P/M_N	= Ratio of pull-up torque – rated torque
U_N	= Rated voltage	M_N	= Rated torque of rotor
I_N	= Rated current	R_M	= Branch resistance
cos φ	= Power factor	$U_{SH\Delta}$	= Heater voltage in delta connection
η	= Efficiency	U_{SHY}	= Heater voltage in star connection
J_R	= Rotor moment of inertia		

DRUM MOTOR DL SERIES DL 0113

Mechanical data for 1-phase asynchronous motor

P_N [W]	n_p	gs	i	v [m/s]	n_A [min ⁻¹]	M_A [Nm]	F_N [N]	FW_{MIN} [mm]	SL_{MIN} [mm]
60	4	3	63.00	0.122	20.6	23.8	420	262	240
60	4	3	49.29	0.156	26.4	18.6	328	262	240
60	4	3	44.09	0.175	29.5	16.6	294	262	240
60	4	3	38.51	0.200	33.8	14.5	256	262	240
60	4	3	30.77	0.251	42.3	11.6	205	262	240
60	4	3	26.84	0.287	48.4	10.1	179	262	240
60	4	3	23.96	0.322	54.3	9.0	160	262	240
60	4	2	15.00	0.514	86.7	6.0	105	262	240
80	6	2	15.00	0.352	59.3	11.6	206	297	275
80	6	2	11.57	0.456	76.9	9.0	159	297	275
110	4	3	63.00	0.122	20.6	43.8	772	282	260
110	4	3	49.29	0.156	26.4	34.2	604	282	260
110	4	3	44.09	0.175	29.5	30.6	541	282	260
110	4	3	38.51	0.200	33.8	26.7	472	282	260
110	4	3	30.77	0.251	42.3	21.4	377	282	260
110	4	3	26.84	0.287	48.4	18.6	329	282	260
110	4	3	23.96	0.322	54.3	16.6	294	282	260
110	4	2	15.00	0.514	86.7	11.0	194	282	260
110	4	2	11.57	0.666	112.3	8.5	149	282	260

P_N = Rated power
 n_p = Number of poles
 gs = Gear stages
 i = Speed ratio
 v = Speed

n_A = Shell rated speed
 M_A = Drum motor rated torque
 F_N = Drum motor rated belt pull
 FW_{MIN} = Minimum drum width
 SL_{MIN} = Minimum shell length

DRUM MOTOR

DL SERIES

DL 0113

Electrical data for 1-phase asynchronous motor

P_N [W]	n_p	n_N [min ⁻¹]	f_N [Hz]	U_N [V]	I_N [A]	$\cos\varphi$	η [%]	J_R [kgcm ²]	I_s/I_N	M_s/M_N	M_B/M_N	M_P/M_N	M_N [Nm]	R_M [Ω]	U_{SH-} [V DC]	C_R [μF]
60	4	1300	50	230	0.75	0.98	0.36	2.3	2.58	1.29	2.6	1.29	0.44	63.5	35	4
80	6	890	50	230	1.35	0.99	0.26	4	1.88	0.7	1.65	0.7	0.86	45.9	46	8
110	4	1300	50	230	1.13	0.88	0.48	3.3	2.93	1.06	2.31	1.06	0.81	32.5	24	6

P_N	= Rated power	I_s/I_N	= Ratio of startup current – rated current
n_p	= Number of poles	M_s/M_N	= Ratio of startup torque – rated torque
n_N	= Rated speed of rotor	M_B/M_N	= Ratio of pull-out torque – rated torque
f_N	= Rated frequency	M_P/M_N	= Ratio of pull-up torque – rated torque
U_N	= Rated voltage	M_N	= Rated torque of rotor
I_N	= Rated current	R_M	= Branch resistance
$\cos\varphi$	= Power factor	U_{SH-}	= Heater voltage for DC units
η	= Efficiency	C_R	= Capacitor size
J_R	= Rotor moment of inertia		

Belt tension diagrams

Belt tension depending on drum width

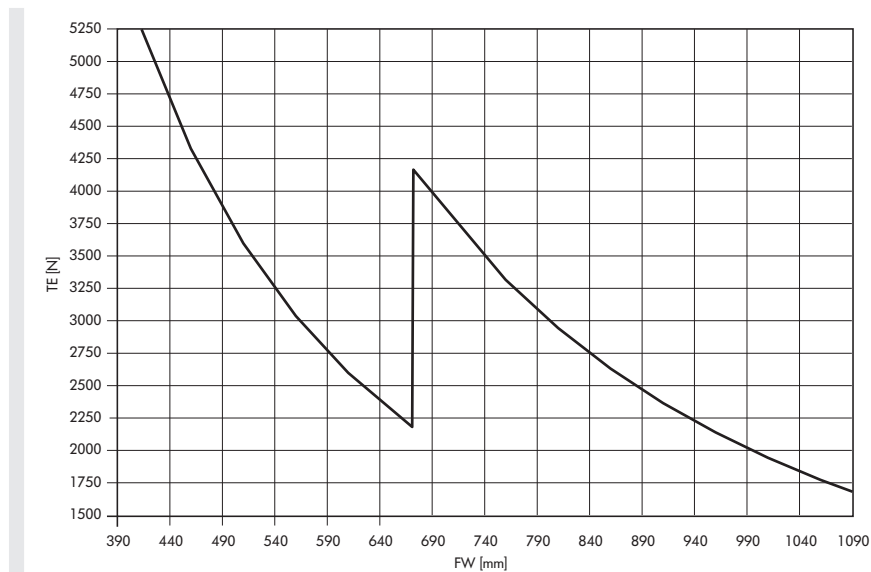

Belt tension depending on rated speed of shell

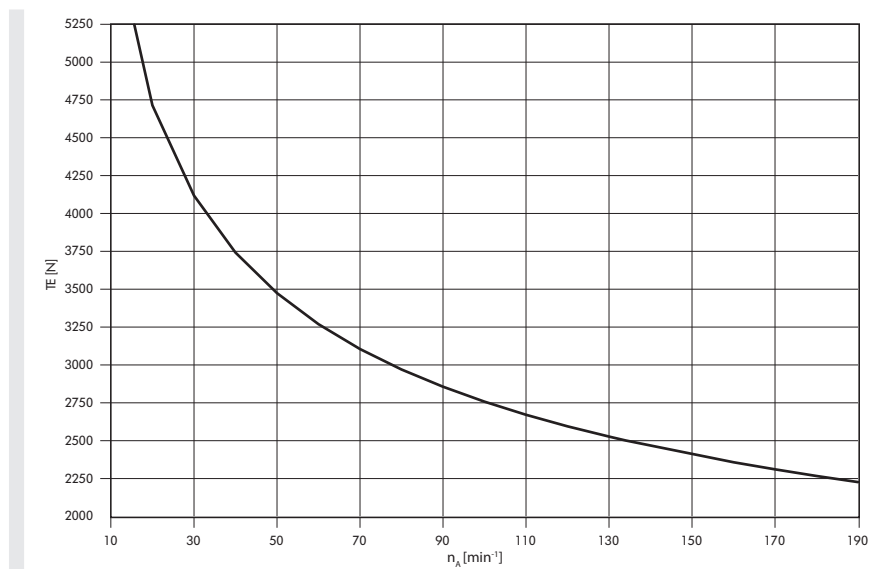

Note: The correct value for the maximum permissible belt tension is determined from the maximum permissible TE value for the speed of the drum motor. For motors with shell length $FW > 400$ mm, check whether the maximum permissible TE value for the jacket length is lower. In this case, use the lower value as maximum permissible TE value.

- TE = Belt tension
- n_A = Shell rated speed
- FW = Drum width

DRUM MOTOR

DL SERIES

DL 0113

Dimensions

Drum motor

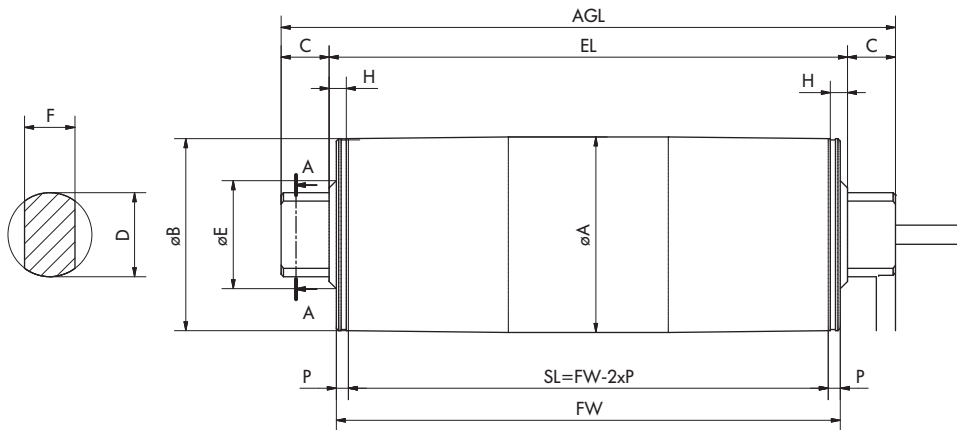

Type	A [mm]	B [mm]	C [mm]	D [mm]	F [mm]	H [mm]	P [mm]	SL [mm]	EL [mm]	AGL [mm]
DL 0113 crowned	113.3	112.4	20	35	21	14	11	FW - 22	FW + 6	FW + 46
DL 0113 cylindrical	113.0	113.0	20	35	21	14	11	FW - 22	FW + 6	FW + 46