



Practice-oriented, scalable and thought out in detail: The new drum motor DM 0138 makes it easy to build a completely individual conveyor system and is dimensioned for the higher requirements for permissible belt tension from industry and belt manufacturers.

With a broader speed spectrum, the DM 0138 covers all possible applications. The clever plug-and-play connection significantly simplifies the installation. Each motor is approved, tested, and modularized so that it can be produced and delivered around the world in the shortest amount of time.

The modular design of the DM 0138 allows a free combination of individual module groups, such as shaft, end cover, shell or steel gear, to perfectly meet the requirements of an application. In addition, various options, such as encoder, brake, backstop, rubber laggings, etc., as well as different accessories are available.

With the platform concept of the DM 0138, it is possible to cover all internal logistics applications in the food processing sector, as well as in industry, distribution and airports.



Technical data

Asynchronous squirrel cage motor	
Insulation class of motor windings	Class F, IEC 34 (VDE 0530)
Voltage	230/400 V ± 5 % (IEC 34/38) Most of the common international voltages and frequencies are available upon request
Frequency	50 Hz
Shaft seal, internal	NBR
Protection rate Motor*	IP69K
Thermal protection	Bi-metal switch
Operating mode	S1
Ambient temperature, 3-phase motor	+2 to +40 °C Low temperature ranges on request
Ambient temperature, 3-phase motor for applications with positive driven belts or no belt	+2 to +25 °C

* The protection rate of the cable connector may deviate.

Design variants and accessories

Laggings	Lagging for friction drive belts Lagging for modular plastic belts Lagging for positive drive solid homogeneous belts
Sprockets	Sprockets only on request
Options	Backstop Electromagnetic holding brake and rectifier* Encoder* Balancing Plug connection
Oils	Food-grade oils (EU, FDA)
Certificate	cULus safety certificates (starting Q1/2019)
Accessories	Idler pulleys; conveyor rollers; mounting brackets; cables; inverters

A combination of encoder and safety holding brake is not possible. In addition, the use of a backstop with a synchronous motor is technically not meaningful.

* Depending on the output and speed, the motor extends by 50–70 mm.

Material variants

The following components can be selected for the drum motor and the electrical connection.
The combination of components depends on the material used.

Component	Version	Aluminum	Mild steel	Stainless steel	Brass/nickel	Technopolymer
Shell	Crowned		●	●		
	Cylindrical		●	●		
	Cylindrical + key for sprockets		●	●		
End housing	Standard	●		●		
Shaft	Standard			●		
	Cross-drilled thread			●		
Gear boxes	Planetary gear box		●			
Electrical connector	Straight connector			●	●	●
	Straight hygienic connector			●		
	Elbow connector			●		●
	Terminal box	●		●		●
	Straight plug connection			●		
	90° plug connection			●		
	90° hygienic connector			●		
Motor winding	Asynchronous motor					
	Synchronous motor					
External seal	PTFE					

Motor variants

Mechanical data for 3-phase asynchronous motor with steel gear

P _N [W]	n _p	g _s	i	v [m/s]	n _A [min ⁻¹]	M _A [Nm]	F _N [N]	FW _{MIN} [mm]	SL _{MIN} [mm]
160	4	3	252	0.04	5.5	238	3454	307	300
160	4	3	150	0.07	9.2	142	2056	307	300
160	4	3	120	0.08	11.5	113	1645	307	300
160	4	3	100	0.1	13.9	95	1371	307	300
370	4	2	73.8	0.14	18.8	169	2452	307	300
370	4	2	63	0.16	22.0	144	2093	307	300
370	4	2	49.2	0.2	28.2	113	1635	307	300
370	4	2	42	0.24	33.1	96	1395	307	300
370	4	2	36	0.28	38.6	83	1196	307	300
370	4	2	30	0.33	46.3	69	997	307	300
370	4	2	27	0.37	51.4	62	897	307	300
370	4	2	24	0.42	57.9	55	797	307	300
370	4	2	20	0.5	69.5	46	664	307	300
370	4	2	16	0.63	86.8	37	532	307	300
370	4	2	12	0.84	115.8	28	399	307	300
370	4	1	9	1.11	154.3	22	315	307	300
550	2	2	73.8	0.28	38.7	123	1776	307	300
550	2	2	63	0.33	45.3	105	1516	307	300
550	2	2	49.2	0.42	58.0	82	1184	307	300
550	2	2	42	0.49	68.0	70	1011	307	300
550	2	2	36	0.57	79.3	60	866	307	300
550	2	2	30	0.69	95.2	50	722	307	300
550	2	2	27	0.76	105.7	45	650	307	300
550	2	2	24	0.86	119.0	40	578	307	300
550	2	2	20	1.03	142.8	33	481	307	300
550	2	2	16	1.29	178.4	27	385	307	300
550	2	2	12	1.72	237.9	20	289	307	300
550	2	1	9	2.29	317.2	16	228	307	300

P_N [W]	np	gs	i	v [m/s]	n_A [min ⁻¹]	M_A [Nm]	F_N [N]	FW_{MIN} [mm]	SL_{MIN} [mm]
750	4	2	42	0.24	33.3	194	2807	357	350
750	4	2	36	0.28	38.9	166	2406	357	350
750	4	2	30	0.34	46.7	138	2005	357	350
750	4	2	27	0.37	51.9	125	1805	357	350
750	4	2	20	0.51	70.0	92	1337	357	350
750	4	2	16	0.63	87.5	74	1069	357	350
750	4	2	12	0.84	116.7	55	802	357	350
750	4	1	9	1.12	155.6	44	633	357	350
1000	2	2	49.2	0.42	57.9	150	2169	357	350
1000	2	2	42	0.49	67.9	128	1851	357	350
1000	2	2	36	0.57	79.2	109	1587	357	350
1000	2	2	30	0.69	95.0	91	1322	357	350
1000	2	2	27	0.76	105.6	82	1190	357	350
1000	2	2	24	0.86	118.8	73	1058	357	350
1000	2	2	20	1.03	142.6	61	882	357	350
1000	2	2	16	1.29	178.2	49	705	357	350
1000	2	2	12	1.72	237.6	36	529	357	350
1000	2	1	9	2.29	316.8	29	418	357	350

Partial load-compliant motors are available on request.

P_N = Rated power	n_A = Shell rated speed
np = Number of poles	M_A = Drum motor rated torque
gs = Gear stages	F_N = Drum motor rated belt pull
i = Speed ratio	FW_{MIN} = Minimum drum width
v = Speed	SL_{MIN} = Minimum shell length

Electrical data for 3-phase asynchronous motor

P_N [W]	np	n_N [min ⁻¹]	f_N [Hz]	U_N [V]	I_N [A]	cosφ	η [%]	J_R [kgcm ²]	I_S/I_N	M_S/M_N	M_P/M_N	M_B/M_N	M_N [Nm]	R_M [Ω]	$U_{SHΔ}$ [V]	U_{SHY} [V]
160	4	1390	50	400	0.46	0.76	0.67	3.98	3.5	1.86	1.86	2.13	1.1	60.2		30.7
160	4	1390	50	230	0.79	0.76	0.67	3.98	3.5	1.86	1.86	2.13	1.1	60.2	18.2	
370	4	1389	50	400	1.01	0.75	0.71	6.48	4.07	2.24	2.00	2.28	2.5	21.1		23.7
370	4	1389	50	230	1.74	0.75	0.71	6.48	4.07	2.24	2.00	2.28	2.5	21.1	13.7	
550	2	2855	50	400	1.28	0.77	0.80	4.21	5.49	2.82	2.82	3.26	1.8	11.8		17.4
550	2	2855	50	230	2.21	0.77	0.80	4.21	5.49	2.82	2.82	3.26	1.8	11.8	10.1	
750	4	1400	50	400	1.86	0.77	0.77	11.45	4.47	2.29	2.07	2.41	5.1	9.1		19.4
750	4	1400	50	230	3.22	0.77	0.77	11.45	4.47	2.29	2.07	2.41	5.1	9.1	11.2	
1000	2	2851	50	400	2.03	0.84	0.84	7.45	6.25	2.91	2.91	3.12	3.4	5.7		14.7
1000	2	2851	50	230	3.52	0.84	0.84	7.45	6.25	2.91	2.91	3.12	3.4	5.7	8.5	

P_N = Rated power	I_S/I_N = Ratio of startup current - rated current
np = Number of poles	M_S/M_N = Ratio of startup torque - rated torque
n_N = Rated speed of rotor	M_B/M_N = Ratio of pull-out torque - rated torque
f_N = Rated frequency	M_P/M_N = Ratio of pull-up torque - rated torque
U_N = Rated voltage	M_N = Rated torque of rotor
I_N = Rated current	R_M = Branch resistance
cosφ = Power factor	$U_{SHΔ}$ = Heater voltage in delta connection
η = Efficiency	U_{SHY} = Heater voltage in star connection
J_R = Rotor moment of inertia	

Belt tension diagrams

Belt tension depending on drum width

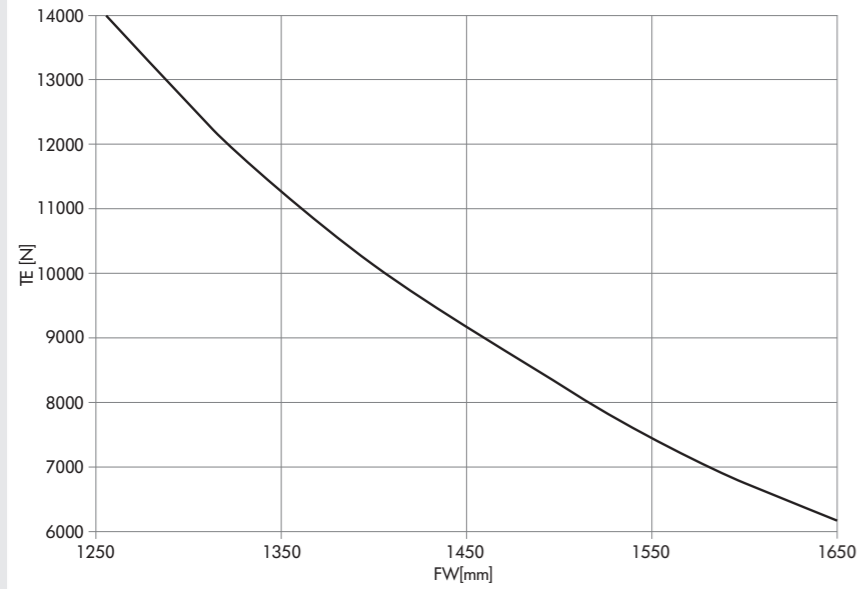

Belt tension depending on rated speed of shell

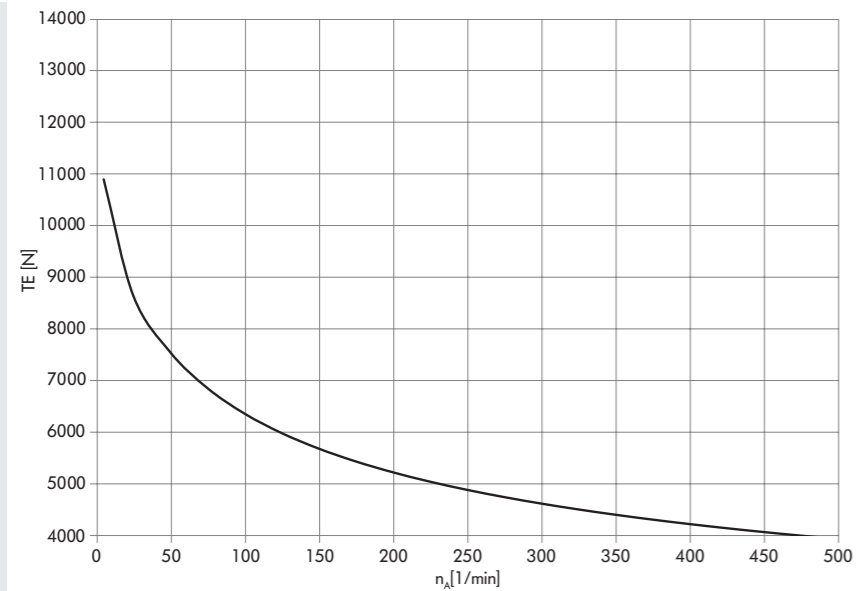

Note: The correct value for the maximum permissible belt tension is determined from the speed of the drum motor. When selecting the motor, also check whether the maximum permissible TE value fits the desired drum width (FW).

- TE = Belt tension
- n_A = Shell rated speed
- FW = Drum width

Dimensions

Drum motor

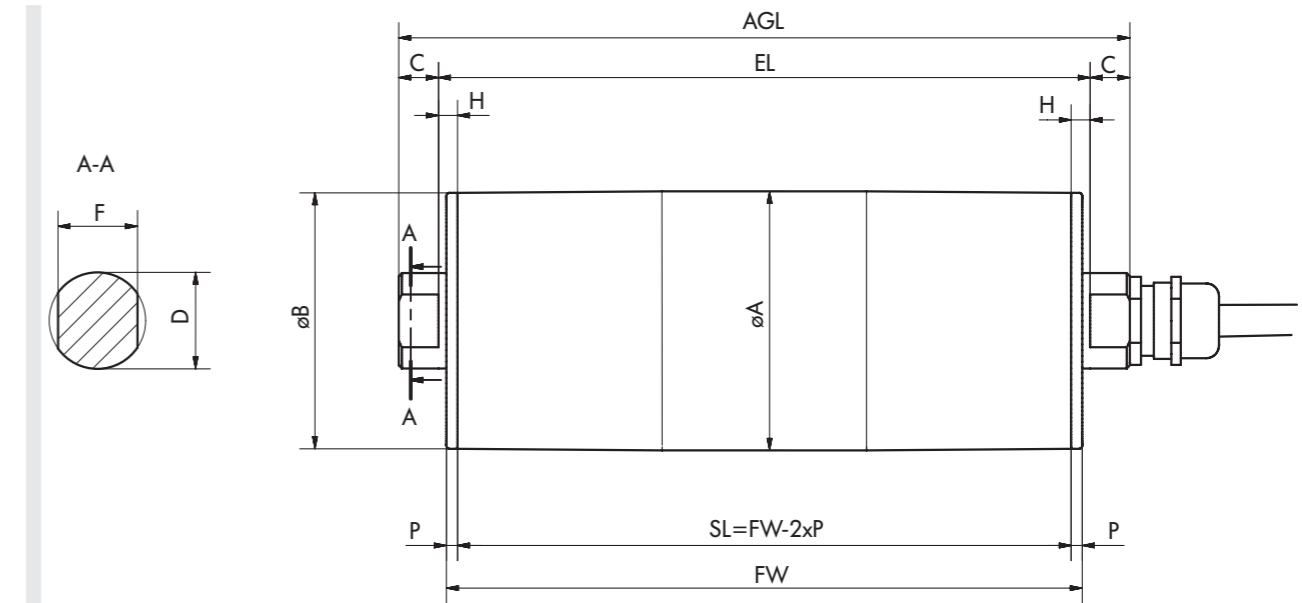

Type	A [mm]	B [mm]	C [mm]	D [mm]	F [mm]	H [mm]	P [mm]	SL [mm]	EL [mm]	AGL [mm]
DM 0138 crowned	138	136	25	30	25	15	3.5	FW - 7	FW + 23	FW + 73
	138	136	25	30	20*	15	3.5	FW - 7	FW + 23	FW + 73
DM 0138 cylindrical	136	136	25	30	25	15	3.5	FW - 7	FW + 23	FW + 73
	136	136	25	30	20*	15	3.5	FW - 7	FW + 23	FW + 73
DM 0138 cylindrical + key	137	137	25	30	25	15	3.5	FW - 7	FW + 23	FW + 73
	137	137	25	30	20*	15	3.5	FW - 7	FW + 23	FW + 73

* Available from Q1/2019

Cable overview

Cable connections

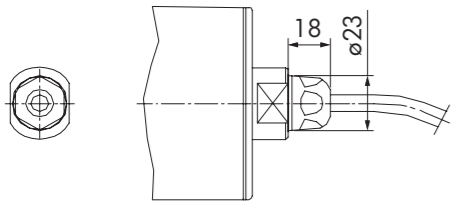

Fig.: Straight hygienic connector, IP69k stainless steel

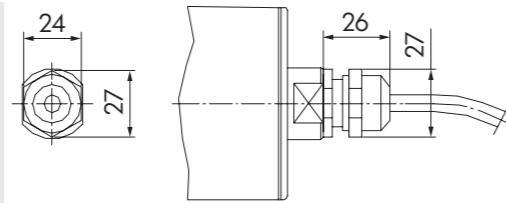

Fig.: Straight connector, brass or stainless steel

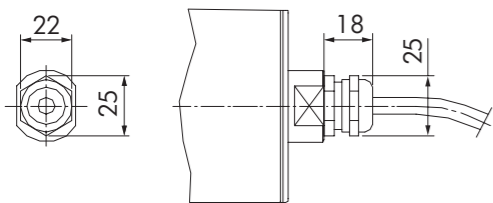

Fig.: Straight EMC connector, brass or stainless steel

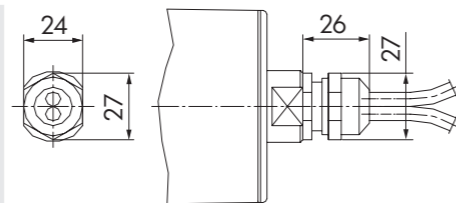

Fig.: Straight connector for encoder, brass or stainless steel

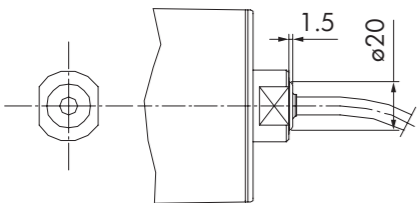

Fig.: Protective cap made of PU

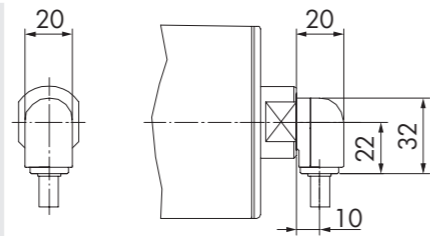

Fig.: Elbow connector, technopolymer

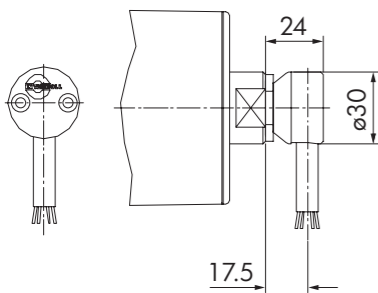

Fig.: Elbow connector, stainless steel, also for encoders

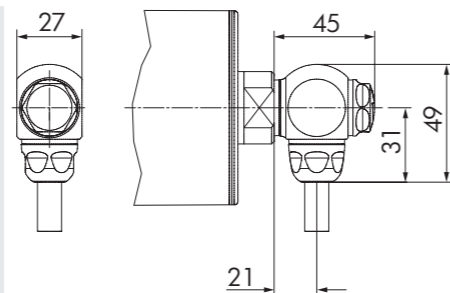

Fig.: 90° hygienic connector

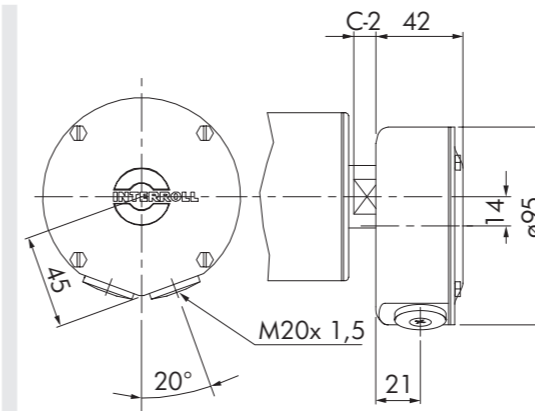

Fig.: Terminal box, stainless steel

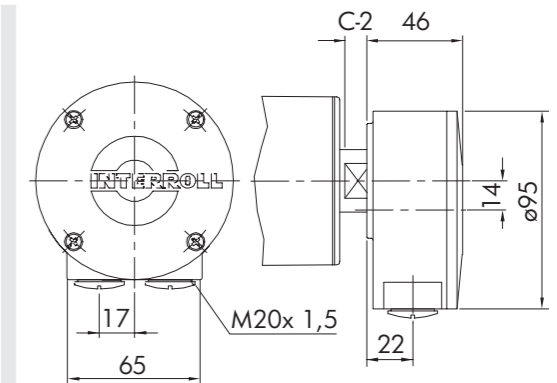

Fig.: Terminal box, aluminum

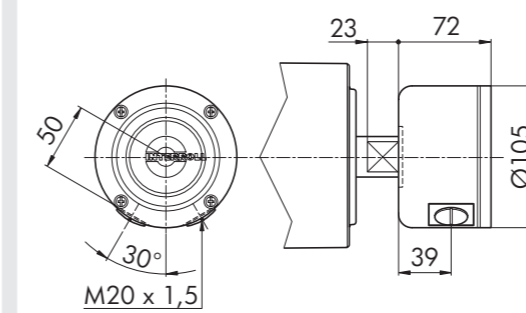

Fig.: Terminal box, techno-polymer

Cable specification: page 51
Available cable lengths: 1 m, 3 m, 5 m, 10 m

All cable connection dimensions are approximate.