



Conveyor Components

Issue 16

CONVEYOR COMPONENTS

- Chain Guide Components Page S002
- Product Handling Components Page S045
- Frame Support Components Page S140
- Miscellaneous Components Page S156

S001 - S189



SUPPORTING AND LEVELLING ELEMENTS

- Articulated Feet in Reinforced Polyamide Page R08
- Articulated Feet Gripper Page R21
- Articulated Feet in Steel Page R34
- Fixed Feet in Steel Page R41
- Threaded Bushings Page R42

R00 - R43



SELF-ALIGNING BEARINGS

- Square Flange Bearing Units Page B04
- Oval Flange Bearing Units Page B14
- Pillow Block Type Bearing Units Page B22
- Compact Pillow Block Type Bearing Units Page B26
- Side Flange Bearing Units Page B28
- Take-up Bearing Units Page B36
- Round Flange Bearing Units Page B38

B00 - B59



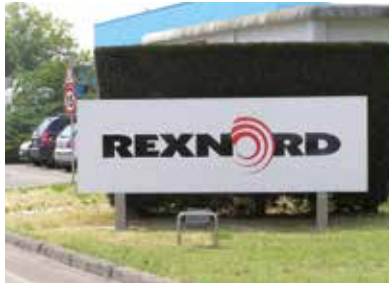

The company

Rexnord is a global company supplying many industries with power transmission and conveying components. The product offering ranges from roller chains, couplings and geared products to conveyor chains, belts and components.

The head office is based in the United States, with several divisions all over the world. The Rexnord FlatTop division is manufacturing conveyor chains, belts and components.

Rexnord is fully committed to meet customer expectations; huge knowledge of the business reduces maintenance costs, eliminates redundant inventories and prevents downtime, all in close co-operation with OEMs and end users. This is a result of Rexnord's focus on product development, application engineering, operations and customer service.

Rexnord FlatTop Europe represents 3 strong brands: Rexnord, MCC and Marbett.

With production facilities in 's-Gravenzande and Correggio, sales offices in The Netherlands and Italy, a large sales group for local service in many countries and distributors all over the world, Rexnord is always close to its customers. In this way a fast and reliable delivery is guaranteed.

Rexnord chains and belts are being used to convey a wide variety of products: bottles, cans, boxes, crates, tires, loose food, glass jars, PET containers, trays; shortly every transport in production halls in virtually any industry.

The product range has been split up over two catalogues, one for Rexnord/MCC Table Top/MatTop chains and one for Marbett conveyor components.

The industries served

As the handling specialist in the field of conveying, the Rexnord product portfolio is providing solutions for complete lines in several industries in order to improve productivity.

In beverage industry palletizers, depalletizers, washers, labelers, fillers, pasteurizers, inliners, outfeeds, elevators and accumulation tables are equipped with slatband chains, curves, sprockets, belts, bearings, leveling elements and many more conveyor components.



For the container manufacturing industry special products and materials are available, such as abrasion resistant polyamide for glass plants, vacuum chains for can making and gripper chains for vertical transport.



A wide range of products is also offered for blanchers, cookers, washers, coolers and processing lines in fruit, vegetables, bakery, confectionary etc. And many more products are available for the handling of packed food.



In automotive industry the products are engineered to meet the most demanding applications, such as rubber processing and tire handling.

This is just a short selection of the applications in which Rexnord products are being used. Among others they have also found their way into pharmaceutical production lines, battery manufacture, paper and cardboard production.

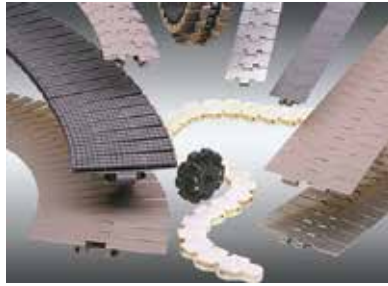
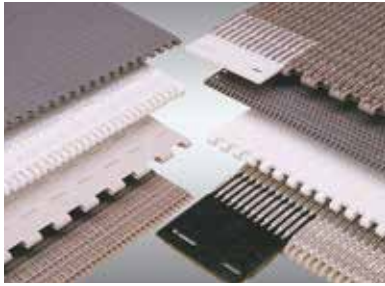

Rexnord and MCC TableTop chains and MatTop belts

The product line can be split up into:



- Steel slatband chains
In various materials ranging from carbon steel to special stainless steel with better wear and sliding properties; types straight running, sideflexing tab, bevel and Magnetflex, with

and without rubber top.

- Plastic slatband chains
Wide range of materials and various executions; single hinge, double hinge, heavy duty, vacuum, lbp rollers and rubber top.



- Plate Top and Gripper chains
Based on the Rexnord roller chains in both stainless and carbon steel; Plate Top chains have steel or plastic top plates; Gripper chains have different types of rubber inserts.

- Case conveyor and Multiflex chains
Different types of acetal for both straight running and sideflexing transport of products varying from heavy crates to small juice packs.



- Curves
Magnetflex, Tab and bevel, as well as straight tracks to support the chain in all parts of the line; there are many standard versions besides the ability to make any special curve needed

in your applications with short delivery times.

- Modular belts
Pitches differ from 0.5 to 2.25 inch to suit any application. Most series have both closed and open top executions; some also available with rubber top for inclined conveying.

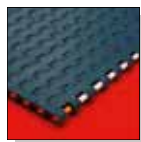

Marbett conveyor components

The product line can be split up into:

- Chain guide components
Profiles, corner tracks, straight tracks, return rollers, serpentine, plugs for connections.



- Product handling components
Guide rails, roller guides, guide rail clamps, guide rail brackets and connecting clamps in plastic or stainless steel.

- Frame support components
Side mounting top brackets, bearing heads, support bases and connecting joints, stainless steel components.



- Supporting and leveling elements
Different versions in steel and plastic, articulated and fixed, with and without gripper bottom and vibration absorbing feet.

- Self-aligning bearings
Square, oval, pillow block, side flange, take-up, round, and other executions, all with open and closed unit. Lubricated for life versions are also available.

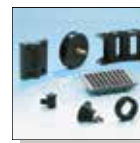

- Miscellaneous components
Line control elements, hinges, locks, knobs, modular transfer roller plates, rollers, tensioners, nozzles, cable carriage chains, shaft collars and nose-over bars.

CHAIN GUIDE COMPONENTS

Chain Guide Profiles Page S002

Roller Guides for Chain Return Page S027

Serpentine Guides for Chain Return Page S036

Plugs for Connection Page S042



PRODUCT HANDLING COMPONENTS

Product-Guides Page S043

Guide-Rail Clamps Page S086

Guide-Rail Brackets Page S102

Connecting Clamps Page S118



FRAME SUPPORT COMPONENTS

Side Mounting top Brackets Page S122

Bearing Heads Page S124

Support Bases Page S126

Connecting Joints Page S180

Support Heads (Stainless steel) Page S130

Connecting Joints (Stainless steel) Page S134



MISCELLANEOUS COMPONENTS

Line Control Elements Page S136

Hinges Page S140

Locks Page S142

Tightening Elements Page S143

Modular transfer roller plate Page S146

Modular Nose-Over Bar Page S150

Shaft collars Page S152

Winding Tensioners Page S154

Side Guide Adjustment Page S156



TECHNICAL INFORMATION

Technical information Page S162

Chain Guide Profiles



Part. S0262 - Pag. S002
Chain guide profile.



Part. S0241 - Pag. S003
Chain guide profile.

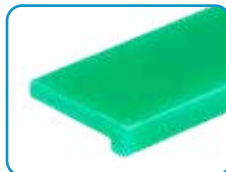

Part. S0243 - Pag. S003
Chain guide profile.



Part. S0822 - Pag. S004
Chain guide profile.



Part. S0825 - Pag. S004
Chain guide profile.



Part. S0251 - Pag. S005
Chain guide profile.



Part. S0261 - Pag. S005
Chain guide profile.



Part. S0840 - Pag. S006
Chain guide profile.

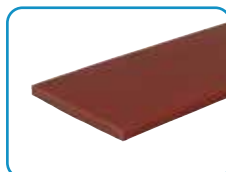

Part. S0244 - Pag. S006
Chain guide profile.

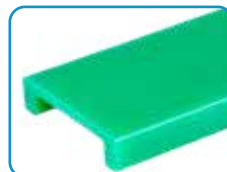

Part. S0784 - Pag. S007
Chain guide profile.



Part. S0362 - Pag. S007
Chain guide profile.



Part. S0387 - Pag. S008
Chain guide profile.



Part. S0634 - Pag. S010
Chain guide profile.



Part. S0814 - Pag. S010
Chain guide profile.



Part. S0674 - Pag. S011
Chain guide profile.



Part. S0422 - Pag. S012
Chain guide profile.



Part. S0369 - Pag. S012
Connecting bar for Part. S0422.



Part. S0885 - Pag. S013
Chain guide profile.



Part. S0366 - Pag. S014
Chain guide profile.



Part. S0367 - Pag. S014
Chain guide profile.



Part. S0368 - Pag. S015
Chain guide profile.



Part. S0885 - Pag. S015
Chain guide profile.



Part. S0858 - Pag. S016
Hinge Joint.



Part. S0371 - Pag. S017
Mounting block for Part. S0366-S0367-S0368.



Part. S0550 - Pag. S018
Chain inlet guide for Part. S0367.



Part. S0768 - Pag. S020
Chain guide profile.



Part. S0767 - Pag. S020
Chain guide profile.



Part. S0356 - Pag. S021
Chain guide profile.



Part. S0765 - Pag. S021
Chain guide profile.



Part. S0766 - Pag. S022
Chain guide profile for modular chains.



Part. S0223 - Pag. S023
Chain guide profile for roller chain ANSI 60.



Part. S0903 - Pag. S024
ViseClamp™.



Part. S0902 - Pag. S024
ViseSplice™.



Part. S0215 - Pag. S025
Clamp.



Part. S0275 - Pag. S025
Clamp.

Roller for Chain Return



Part. S0153 - Pag. S027
Snap-on wear shoe.

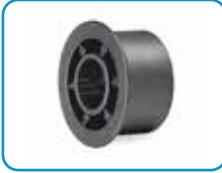

Part. S0073 - Pag. S028
Roller \varnothing 42,5 mm. For K82,5.
For K82,5/pitch 83,5-88.



Part. S0126 - Pag. S028
Distance gear.



Part. S0421 - Pag. S029
Roller \varnothing 42,5 mm. Multiple strands K82,5 / pitch 83,5.



Part. S0826 - Pag. S031
Roller.



Part. S0827 - Pag. S031
Guide flange.



Part. S0782 - Pag. S030
Double roller.
 \varnothing 50 mm.



Part. S0556 - Pag. S032
Roller \varnothing 60 mm. For K82,5. Multiple strand K82,5 / pitch 83,5-88.



Part. S0554 - Pag. S032
Roller \varnothing 60 mm. Multiple strands K82,5/pich 83,5-85.



Part. S0614 - Pag. S033
Roller \varnothing 60 mm. For K82,5. Multiple strand K82,5 / pitch 83,5-88.



Part. S0613 - Pag. S033
Roller \varnothing 60 mm. Multiple strand K82,5/pitch 83,5-85.



Part. S0758 - Pag. S034
Double roller.
 \varnothing 60 mm.



Part. S0555 - Pag. S034
Guiding flange for part. S0554-S0613-S0657-S0758.



Part. S0657 - Pag. S035
Roller \varnothing 60 mm. Multiple strand K82,5 / pitch 85.

Serpentine Guides for Chain Return



Part. S0729 - Pag. S036
Chain return guide.



Part. S0524 - Pag. S036
Sliding profile.



Part. S0523 - Pag. S037
Spacer.



Part. S0533 - Pag. S039
Striker.

Expansion Plugs



Part. S0565 - Pag. S042
Expansion plug for tubes
ø 18-20 mm.

Product Guides



Part. S0771 - Pag. S043
Overhead transport PET bottles.



Part. S0594 - Pag. S045
Overhead transport PET bottles.



Part. S0654 - Pag. S045
Overhead transport PET bottles.



Part. S0715 - Pag. S045
Side guide. Delicate containers (PET empty).



Part. S0308 - Pag. S046
Overhead transport PET bottles.



Part. S0317 - Pag. S048
Half-round guide rail. Delicate containers (PET empty).



Part. S0223 - Pag. S048
Flat guide rail. Middle delicate containers (PET full).

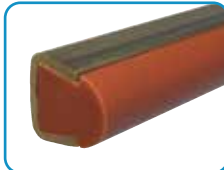

Part. S0219 - Pag. S049
Round guide rail. Middle strong containers (glass).



Part. S0247 - Pag. S049
Round guide rail. Middle strong containers (glass).



Part. S0346 - Pag. S050
Half-round guide rail. Low side load (brick).



Part. S0770 - Pag. S051
Flat guide rail. Rugged containers.



Part. S0768 - Pag. S052
Flat guide rail. Rugged containers.



Part. S0767 - Pag. S052
Flat guide rail. Rugged containers.



Part. S0273 - Pag. S053
Flat guide rail. Rugged containers.



Part. S0765 - Pag. S053
Extra flat guide rail.



Part. S0422 - Pag. S054
Extra flat guide rail. Rugged containers.

Product Range



Part. S0369 - Pag. S054
Connecting bar for
Part.S0754-S0755-S0756-
S0757-S0656.



Part. S0643 - Pag. S056
Metal profile for
Part. S0642.
In aluminium



Part. S0645 - Pag. S057
Profile for round steel rods.

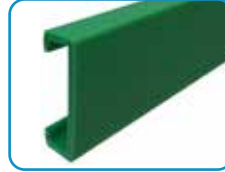

Part. S0539 - Pag. S057
Extra flat guide rail. Assembly
with 40x8 mm plate.



Part. S0191-S0296 - Pag. S058
Extra large guide rail.
Assembly with 60x6 mm plate.



Part. S0378-S0379 - Pag. S059
Joint clamp for
Part. S0191-S0296.



Part. S0581 - Pag. S060
Roller side guide.
Thin-walled containers.



Part. S0581 - Pag. S061
Roller side guide.
Thin-walled containers.



Part. S0580 - Pag. S062
Roller side guide.
Medium strength containers.



Part. S0557 - Pag. S062
Roller centre guide.
Medium strength containers.



Part. S0570 - Pag. S063
Divider module for
Part. S0557.



Part. S0580 - Pag. S064
Roller side guide.
Medium strength containers.



Part. S0537 - Pag. S065
Metal profile 40x8.



Part. S0535 - Pag. S065
Bolts set for Part. S0537.



Part. S0757 - Pag. S066
Roller side guides with
cylinder rollers, in aluminium.



Part. S0755 - Pag. S067
Centre guides with cylinder rollers, in aluminium.



Part. S0757 - Pag. S068
Roller side guides with cylinder rollers, in aluminium.



Part. S0755 - Pag. S069
Centre guides with cylinder rollers, in aluminium.



Part. S0868 - Pag. S070
Roller side guides with cylinder rollers, in aluminium.



Part. S0869 - Pag. S071
Centre guides with cylinder rollers, in aluminium.



Part. S0868 - Pag. S072
Roller side guides with cylinder rollers, in aluminium.



Part. S0869 - Pag. S073
Centre guides with cylinder rollers, in aluminium.



Part. S0756 - Pag. S074
Pearl™ roller side guide in aluminium.



Part. S0754 - Pag. S075
Pearl™ roller centre guide in aluminium.



Part. S0756 - Pag. S076
Pearl™ roller side guide in aluminium.



Part. S0856 - Pag. S078
Roller side guides in aluminium.



Part. S0857 - Pag. S079
Roller centre guides in aluminium.



Part. S0852 - Pag. S081
Separation Block.



Part. S0854 - Pag. S081
Separation Block.



Part. S0760 - Pag. S080
Separation Block.



Part. S0128S - Pag. S082
Sideflexing Roller side guide. Rugged containers.



Part. S0128 - Pag. S082
Roller side guide. Rugged containers.



Part. S0128 - Pag. S082
Roller side guide. Rugged containers.



Part. S0128 - Pag. S085
Roller side guide. Rugged containers.



Part. S0218 - Pag. S085
Guide rail bending machine (manual).

Guide Rail Clamps



Part. S0210P - Pag. S086
Guide rail clamp.



Part. S0275 - Pag. S087
Guide rail clamp.



Part. S0211 - Pag. S087
Guide rail clamp
(adjustable).



Part. S0213 - Pag. S088
Guide rail clamp
(double).



Part. S0213 - Pag. S088
Guide rail clamp
(double).



Part. S0736-S0737-S0738
Pag. S089
Sliding joint clamp.



Part. S0903 - Pag. S091
ViseClamp™.



Part. S0215 - Pag. S091
Guide rail clamp.



Part. S0694 - Pag. S090
Guide rail clamp
with two fixing screw.



Part. S0217 - Pag. S090
Guide rail clamp
(double).



Part. S0237 - Pag. S092
Guide rail clamp
(adjustable).



Part. S0082P - Pag. S094
Guide rail clamp.



Part. S0159-S0437 - Pag. S095
Guide rail clamp
(adjustable).



Part. S0071 - Pag. S096
Guide rail clamp
(double).



Part. S0070 - Pag. S096
Guide rail clamp
(double).



Part. S0698 - Pag. S097
Guide rail clamp
with two fixing screws.



Part. S0662 - Pag. S097
Guide rail clamp.



Part. S0050 - Pag. S098
Guide rail clamp
(double).



Part. S0190 - Pag. S100
Guide rail clamp.



Part. S0184 - Pag. S100
Guide rail clamp.



Part. S0298 - Pag. S101
Guide rail clamp.



Part. S0298 - Pag. S101
Guide rail clamp.

Guide- Rail Brackets



Part. S0708 - Pag. S102
Bracket with eyebolt.



Part. S0107 - Pag. S103
Bracket with eyebolt.



Part. S0617 - Pag. S103
Bracket with eyebolt.



Part. S0140 - Pag. S104
Bracket with eyebolt.



Part. S0632 - Pag. S105
Adjustable bracket.



Part. S0637 - Pag. S106
Adjustable bracket.



Part. S0862 - Pag. S107
Swivel head.



Part. S0256 - Pag. S107
Swivel head.



Part. S0192 - Pag. S108
Swivel head.



Part. S0061 - Pag. S110
Spacer.



Part. S0725 - Pag. S111
Spacer.



Part. S0226-S0336 - Pag. S112
Drip tray support.
Straight Rod.



Part. S0338 - Pag. S113
Mounting plate for
Part. S0226-S0336.



Part. S0699 - Pag. S115
Side bracket.



Part. S0692 - Pag. S114
Side bracket.



Part. S0661 - Pag. S116
Cross clamp.



Part. S0732 - Pag. S116
Cross clamp
with Quick-Set.



Part. S0763 - Pag. S117
T-clamp with eyebolt,
with knob.

Adjustable Brackets Part.	Fixed Brackets Part.			
S0704+S0192 (S0699+S0192)	-	42,5	35,5	52 (128)
-	S0708	42,5	-	67,5
S0704+S0192 (S0699+S0192)	-	60	53	52 (128)
-	S0081-S0088	-	58	36
-	S0705	61	61	31
-	S0107	-	64,5	45
-	S0708	64,5	-	67,5
S0682-S0677	-	67	-	65
-	S0072-S0089	67	-	42,8
S0635-S0637-S0638 (S0650-S0652-S0653)	-	68	-	64 (48)
-	S0599	68	-	64
S0679	-	70	-	65
S0704+S0192 (S0699+S0192)	-	80	73	52 (128)
-	S0140	81	-	50
-	S0085	84,5	-	42
S0636 (S0651)	-	86	-	64 (48)
-	S0097-S0010	86	-	42
-	S0617	87	-	49
S0679	-	87,5	-	65
S0542-S0543-S0544	-	90	86	51
S0681	-	105,5	-	65
S0679	-	107,5	-	65
S0541	-	108	104	51
S0704+S0192 (S0699+S0192)	-	110	103	52 (128)
S0681	-	123	-	65
S0679	-	137,5	-	65
S0681	-	143	-	65
S0704+S0192 (S0699+S0192)	-	150	143	52 (128)
S0681	-	173	-	65
S0679	-	177,5	-	65
S0681	-	213	-	65

P = to increase the distance use the proper spacer

Connecting Clamps



Part. S0340 - Pag. S118
Cross clamp.
Round and square holes.



Part. S0174 - Pag. S118
Cross clamp. Round hole.



Part. S0339 - Pag. S120
T clamp.



Part. S0786 - Pag. S121
Cross clamp.



Part. S0786 - Pag. S121
Cross Clamp,
with knob.

**Side
Mounting
top Brackets**



Part. S0199 - Pag. S122
Side mounting top bracket for tubes \varnothing 48,3-50,8 square 38-40.



Part. S0685 - Pag. S135
Side mounting top bracket for tubes \varnothing 48,3-50,8-60,3.

**Bearing
Heads**



Part. S0198 - Pag. S124
Bearing head for tubes \varnothing 48,3-50,8 square 38-40.



Part. S0280 - Pag. S125
Bearing head for tubes \varnothing 48,3-50,8-60,3.

**Support
Bases**



Part. S0615 - Pag. S126
Support base for tubes \varnothing 38,1-42,4-48,3-50,8-60,3.



Part. S0618 - Pag. S127
Support base for tubes \varnothing 38,1-42,4-48,3-50,8-60,3.



Part. S0611 - Pag. S127
Support base for tubes square 40-50-60.



Part. S0619 - Pag. S128
Support base for tubes \varnothing 42,4-48,3-50,8-60,3.



Part. S0616 - Pag. S129
Support base for tubes \varnothing 42,4-48,3-50,8-60,3.

**Connecting
Joints**



Part. S0562 - Pag. S130
Connecting joint for tubes \varnothing 33,7-38,1-42,4-48,3.



Part. S0563 - Pag. S130
Connecting joint for tubes \varnothing 50,8-60,3.



Part. S0137 - Pag. S132
Connecting joint for tubes \varnothing 48,3-60,3.



Part. S0686 - Pag. S134
Connecting joint for tubes \varnothing 48,3.

Line Control Elements



Part. S0342 - Pag. S136
Assembly kit for photocells or sensors



Part. S0341 - Pag. S136
Assembly kit for photocells or sensors



Part. S0372 - Pag. S138
Universal clamp for photocells or reflectors.



Part. S0518 - Pag. S139
Control contact lever.

Hinges and Locks



Part. S0337 - Pag. S140
270° hinge.



Part. S0260 - Pag. S140
170° hinge.



Part. S0272 - Pag. S142
Lock.

Tightening Elements



Part. S0303 - Pag. S143
Ratchet handle clamping.



Part. S0182 - Pag. S144
Tightening knob.



Part. S0183 - Pag. S144
Tightening knob.



Part. S0185 - Pag. S145
Tightening knob.

Modular transfer roller plate



Part. S0846 - Pag. S148
End transfer module (with lip).



Part. S0847 - Pag. S148
End transfer module (with lip).



Part. S0848 - Pag. S148
End transfer module (with lip).



Part. S0849 - Pag. S148
End transfer module.



Part. S0850 - Pag. S148
Assembly bar.



Part. S0864 - Pag. S148
L Profile.



Part. S0567 - Pag. S146
End transfer module (with lip).



Part. S0672 - Pag. S146
End transfer module (with lip).



Part. S0569 - Pag. S147
End transfer module.



Part. S0568 - Pag. S147
Centre transfer module.



Part. S0063-S0095
Pag. S083
Roller.

**Modular
Nose-Over
Bar**

Part. S0905 - Pag. S150
Dynamic "Nose-Over"
bar standard profile.



Part. S0905 - Pag. S151
Modular "Nose-Over"
bar standard profile.



Part. S0905 - Pag. S151
Modular "Nose-Over"
bar low profile.

**Shaft
collars**

Part. S0612 - Pag. S152
Split shaft collar
(with round bore).



Part. S0612 - Pag. S153
Split shaft collar
(with square bore).

**Winding
Tensioners**

Part. S0075 - Pag. S154
Winding tensioner.

**Side Guide
Adjustment**

Part. S0837 - Pag. S156
Side Guide Adjustment.

Part. S0262

Chain - guide profile

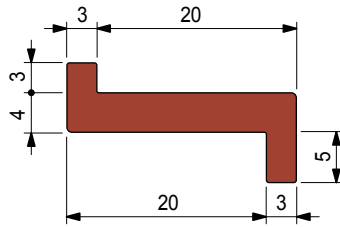

Material UHMWPE	Packaging metres	Code
ULF™ brown red	45	UL640913
Black	45	63651

- Standard packaging: coil.

- **Material:** Polyethylene UHMWPE with molecular density 5.600.000 g/mol.
Characteristics: new material Polyethylene ULF™ brown red (UHMWPE): reduced friction coefficient, higher wear resistance.
- **Linear expansion coefficient:** $2 \times 10^{-4} \text{ } ^\circ\text{C}^{-1}$
Calculation of thermal expansion see Technical information.
- **Operating temperature Green Black:**
In air (- 40 to + 80 °C).
In hot water (+ 70 °C).
- **Operating temperature ULF™ brown red:**
In air (- 40 to + 45 °C).
In hot water (+ 45 °C).
- **Polyethylene ULF™ is FDA approved**
Polyethylene ULF™ complies with the Code of Federal Regulations Title 21, § 177.1520 "Olefin Polymers" of the Food and Drug Administration (FDA) of April 1, 2008.
- **Coefficient of friction between chain POM and wearstrip ULF™:** 0,08.
Note: for calculation of chain pull refer to Technical Support.
- **Position of guides.** See Technical information.

- **TableTop® chains series 812 - 815 - 820 - 831 - 881TAB - 8811TAB - 879TAB - 880TAB**

Chain width 82,5 mm (K 325) / Guide clearance 45 mm

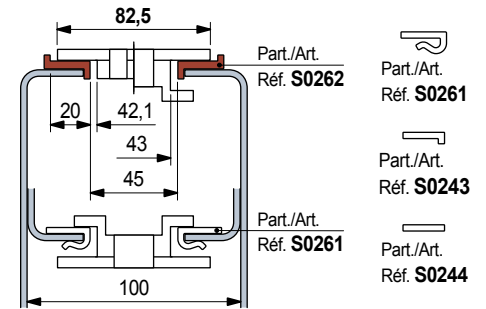

Chain width 114,3 mm (K 450)

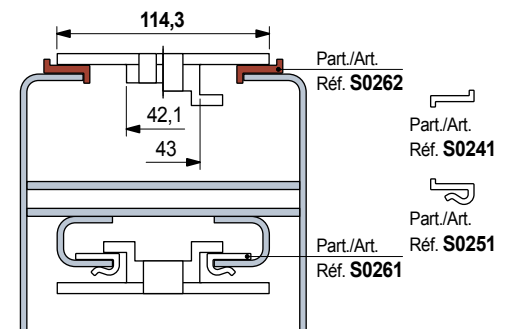

- **Material:** Polyethylene UHMWPE with molecular density 5.600.000 g/mol.
Characteristics: new material Polyethylene ULF™ brown red (UHMWPE): reduced friction coefficient, higher wear resistance.
- **Linear expansion coefficient:** $2 \times 10^{-4} \text{ } ^\circ\text{C}^{-1}$
Calculation of thermal expansion see Technical information.
- **Operating temperature Green Black:**
In air (- 40 to + 80 °C).
In hot water (+ 70 °C).
- **Operating temperature ULF™ brown red:**
In air (- 40 to + 45 °C).
In hot water (+ 45 °C).
- **Polyethylene ULF™ is FDA approved**
Polyethylene ULF™ complies with the Code of Federal Regulations Title 21, § 177.1520 "Olefin Polymers" of the Food and Drug Administration (FDA) of April 1, 2008.
- **Coefficient of friction between chain POM and wearstrip ULF™:** 0,08.
Note: for calculation of chain pull refer to Technical Support.
- **Position of guides.** See Technical information.

• **TableTop®** chains series 812 - 815 - 820 - 831 - 881TAB - 8811TAB - 879TAB - 880TAB

Chain width 82,5 mm (K 325) / Pitch 88 mm

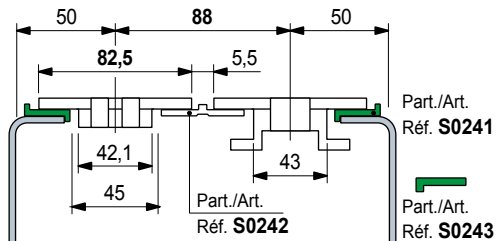

Chain width 82,5 mm (K 325) / Pitch 85 mm

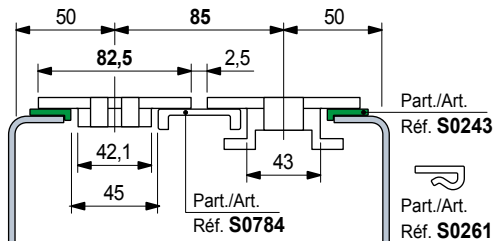

Chain width 114,3 mm (K 450)

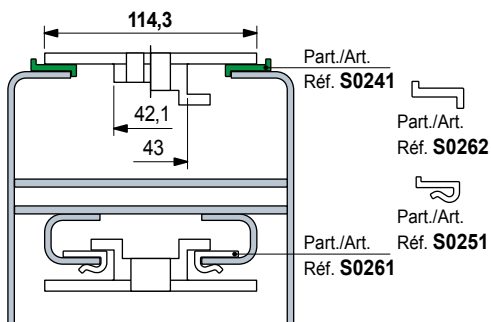

Chain - guide profile

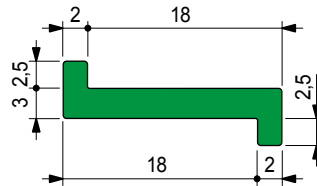

Part. S0241



Material UHMWPE	Packaging metres	Code
Green	80	63641

- Standard packaging: coil.

Chain - guide profile

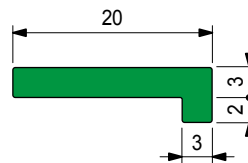

Part. S0243



Material UHMWPE	Packaging metres	Code
Green	90	63701

- Standard packaging: coil.

- Accessories:

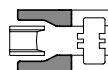

Chain inlet guide shoe side Part. S0551.

Part. S0822



Chain - guide profile

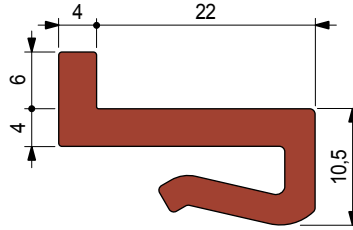

Material UHMWPE	Length metres	Code
ULF™ brown red	6	UL642623
Green	3	632713

- Applicable to 2,5 to 3,5 mm thick sheet metal.
- Can be used in combination with Part. S0362.
- Packaging: 48 metres.

- **Material:** Polyethylene UHMWPE with molecular density 5.600.000 g/mol.
Characteristics: new material Polyethylene ULF™ brown red (UHMWPE): reduced friction coefficient, higher wear resistance.
- **Linear expansion coefficient:** $2 \times 10^{-4} \text{ } ^\circ\text{C}^{-1}$
Calculation of thermal expansion see Technical information.
- **Operating temperature Green Black:**
In air (- 40 to + 80 °C).
In hot water (+ 70 °C).
- **Operating temperature ULF™ brown red:**
In air (- 40 to + 45 °C).
In hot water (+ 45 °C).
- **Polyethylene ULF™ is FDA approved**
Polyethylene ULF™ complies with the Code of Federal Regulations Title 21, § 177.1520 "Olefin Polymers" of the Food and Drug Administration (FDA) of April 1, 2008.
- **Coefficient of friction between chain POM and wearstrip ULF™:** 0,08.
Note: for calculation of chain pull refer to Technical Support.
- **Position of guides.** See Technical information.

Chain width 84 mm Pitch 85 mm

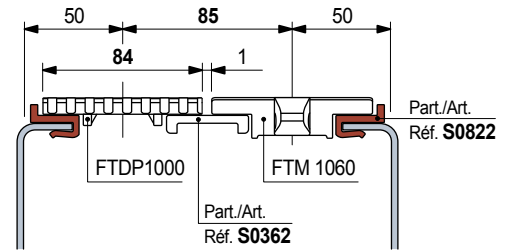

Part. S0825



Chain - guide profile

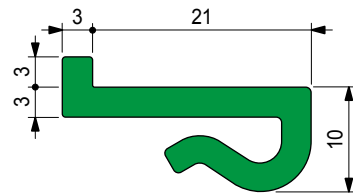

Material UHMWPE	Packaging metres	Code
Green	40	632033
ULF		UL654513U

- Applicable to 2,5 to 3,5 mm thick sheet metal.
- Can be used in combination with Part. S0784.
- Standard packaging: coil.

Chain width 82,5 mm (K 325) / Pitch 85 mm

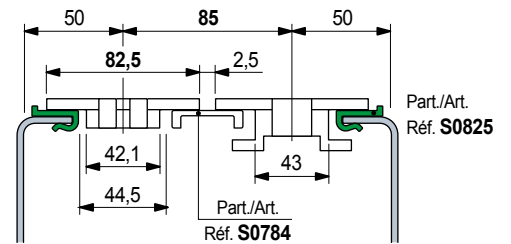

- **Material:** Polyethylene UHMWPE with molecular density 5.600.000 g/mol.
Characteristics: new material Polyethylene ULF™ brown red (UHMWPE): reduced friction coefficient, higher wear resistance.
- **Linear expansion coefficient:** $2 \times 10^{-4} \text{ } ^\circ\text{C}^{-1}$
Calculation of thermal expansion see Technical information.
- **Operating temperature Green Black:**
In air (- 40 to + 80 °C).
In hot water (+ 70 °C).
- **Operating temperature ULF™ brown red:**
In air (- 40 to + 45 °C).
In hot water (+ 45 °C).
- **Polyethylene ULF™ is FDA approved**
Polyethylene ULF™ complies with the Code of Federal Regulations Title 21, § 177.1520 "Olefin Polymers" of the Food and Drug Administration (FDA) of April 1, 2008.
- **Coefficient of friction between chain POM and wearstrip ULF™:** 0,08.
Note: for calculation of chain pull refer to Technical Support.
- **Position of guides.** See Technical information.

Chain width 82,5 mm (K 325) / Guide clearance 45 mm

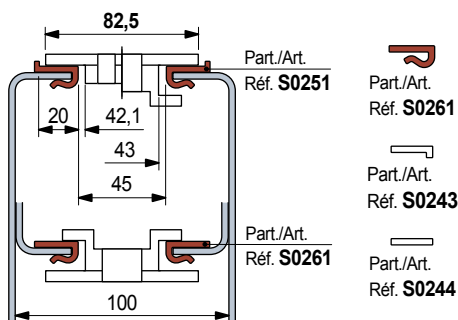

Chain width 82,5 mm (K 325) / Pitch 85 mm

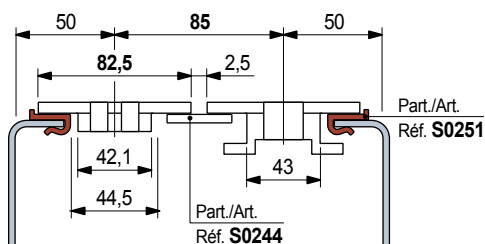

Chain width 114,3 mm (K 450)

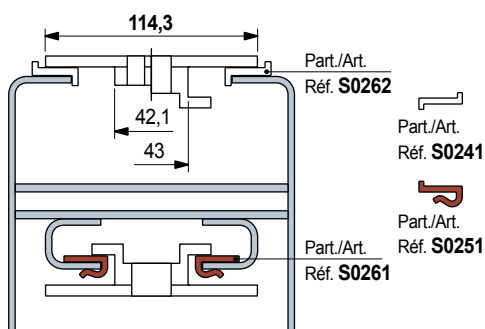

Chain - guide profile

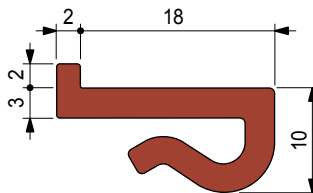

Part. S0251



Material UHMWPE	Packaging metres	Code
ULF™ brown red	40	UL642553
Green	40	63631

- Applicable to 2,5 to 3,5 mm thick sheet metal.
- Standard packaging: coil.

Chain - guide profile

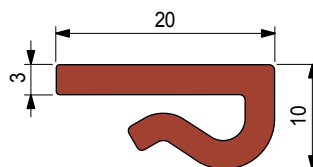

Part. S0261



Material UHMWPE	Packaging metres	Code
ULF™ brown red	40	UL634533N
Green	40	65681

- Applicable to 2,5 to 3,5 mm thick sheet metal.
- Standard packaging: coil.
- Accessories:

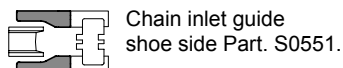

Part. S0840



■ Chain - guide profile

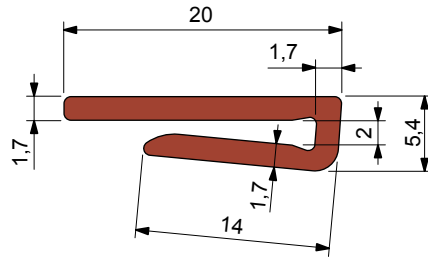

Material	Packaging metres	Code
UHMWPE ULF™ brown red	40	UL642693

- Applicable to 2 mm thick sheet metal.
- Standard packaging: coil.

Part. S0244



■ Chain - guide profile

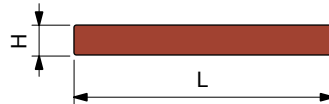

Material	L x H mm	Packaging metres	Code
UHMWPE Green	40 x 3	60	63661

- Standard packaging: coil.
- Accessories:

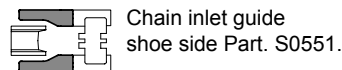

- **Material:** Polyethylene UHMWPE with molecular density 5.600.000 g/mol.
Characteristics: new material Polyethylene ULF™ brown red (UHMWPE): reduced friction coefficient, higher wear resistance.
- **Linear expansion coefficient:** $2 \times 10^{-4} \text{ } ^\circ\text{C}^{-1}$
Calculation of thermal expansion see Technical information.
- **Operating temperature Green Black:**
In air (- 40 to + 80 °C).
In hot water (+ 70 °C).
- **Operating temperature ULF™ brown red:**
In air (- 40 to + 45 °C).
In hot water (+ 45 °C).
- **Polyethylene ULF™ is FDA approved**
Polyethylene ULF™ complies with the Code of Federal Regulations Title 21, § 177.1520 "Olefin Polymers" of the Food and Drug Administration (FDA) of April 1, 2008.
- **Coefficient of friction between chain POM and wearstrip ULF™:** 0,08.
Note: for calculation of chain pull refer to Technical Support.
- **Position of guides.** See Technical information.

- ZeroGap™ chains serie 1775

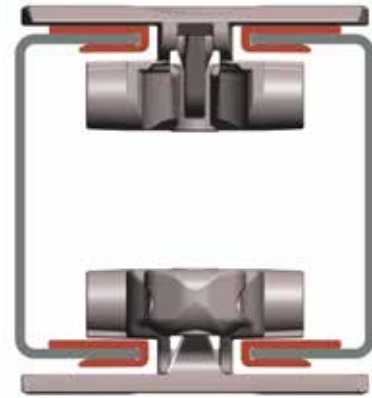

Chain width 82,5 mm (K 325) / Pitch 85 mm

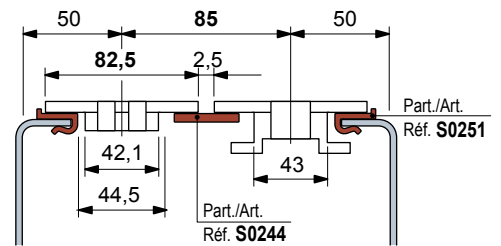

- **Low backline pressure chains series SLBP 882 TAB - SLBP 821**

Chain width 190,5 mm (K 750)

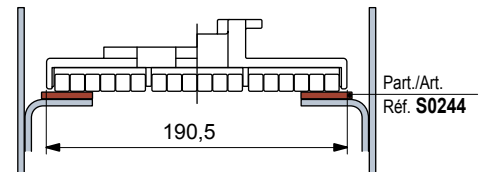

Chain width 95,2 mm (K 375)

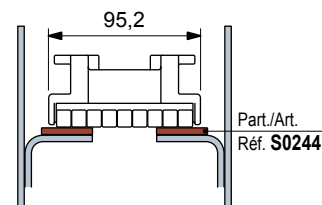

- **Material:** Polyethylene UHMWPE with molecular density 5.600.000 g/mol.
Characteristics: new material Polyethylene ULF™ brown red (UHMWPE): reduced friction coefficient, higher wear resistance.
- **Linear expansion coefficient:** $2 \times 10^{-4} \text{ } ^\circ\text{C}^{-1}$
Calculation of thermal expansion see Technical information.
- **Operating temperature Green Black:**
In air (- 40 to + 80 °C).
In hot water (+ 70 °C).
- **Operating temperature ULF™ brown red:**
In air (- 40 to + 45 °C).
In hot water (+ 45 °C).
- **Polyethylene ULF™ is FDA approved**
Polyethylene ULF™ complies with the Code of Federal Regulations Title 21, § 177.1520 "Olefin Polymers" of the Food and Drug Administration (FDA) of April 1, 2008.
- **Coefficient of friction between chain POM and wearstrip ULF™:** 0,08.
Note: for calculation of chain pull refer to Technical Support.
- **Position of guides.** See Technical information.

Chain width 82,5 mm (K 325) / Pitch 85 mm

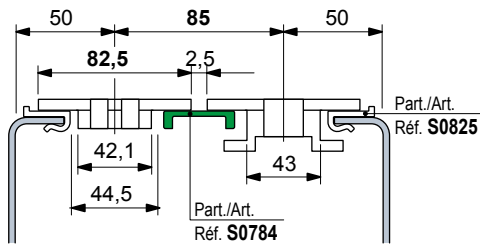

Chain width 82,5 mm (K 325) / Pitch 85 mm

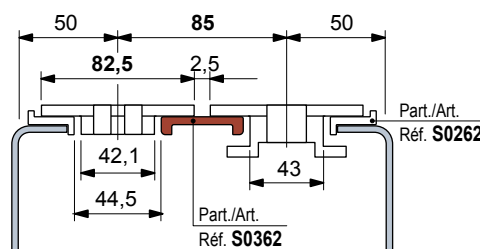

Chain - guide profile

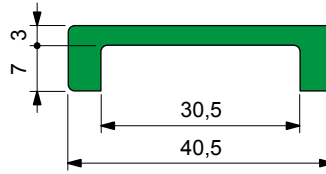

Part. S0784



Material UHMWPE	Length metres	Code
Green	3	620513

- Packaging: 48 metres.

Chain - guide profile

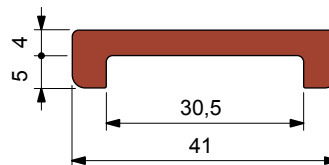

Part. S0362



Material UHMWPE	Length metres	Code
ULF™ brown red	3	UL635293
Green	6	67435

- Packaging: 48 metres.

Part. S0387

■ Chain - guide profile



Reinforced version

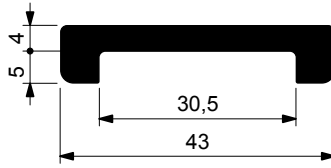

Material	Length metres	Code
UHMWPE		
Black	3	694351

- Can be used in combination with Part. S0386.
- Packaging: 48 metres.

- **Material:** Polyethylene UHMWPE with molecular density 5.600.000 g/mol.
Characteristics: new material Polyethylene ULF™ brown red (UHMWPE): reduced friction coefficient, higher wear resistance.
- **Linear expansion coefficient:** $2 \times 10^{-4} \text{ } ^\circ\text{C}^{-1}$
Calculation of thermal expansion see Technical information.
- **Operating temperature Green Black:**
In air (- 40 to + 80 °C).
In hot water (+ 70 °C).
- **Operating temperature ULF™ brown red:**
In air (- 40 to + 45 °C).
In hot water (+ 45 °C).
- **Polyethylene ULF™ is FDA approved**
Polyethylene ULF™ complies with the Code of Federal Regulations Title 21, § 177.1520 "Olefin Polymers" of the Food and Drug Administration (FDA) of April 1, 2008.
- **Coefficient of friction between chain POM and wearstrip ULF™:** 0,08.
Note: for calculation of chain pull refer to Technical Support.
- **Position of guides.** See Technical information.

• TableTop® chains series 820 - 880TAB

Chain width 87 mm (K 343) / Pitch 88 mm

Multi strand conveyors, with 82,5 mm width chains and pitch 88 mm, can be modified to convey PET bottles with pethal bottom or other unstable products.

Change chains (from 82,5 mm to 87 mm width) and wear strip, in this way the Gap between chains is reduced (from 5,5 mm to 1 mm) while the conveyor frame is unchanged (pitch 88 mm).

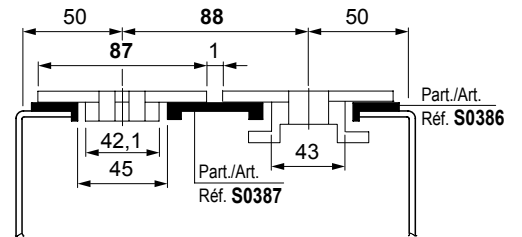

Part. S0634



■ Chain - guide profile

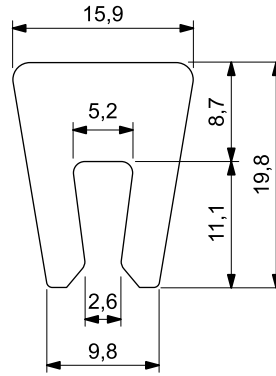

Material UHMWPE	Length metres	Code
White	3	634073
	6	650962

- Applicable to 4 mm thick sheet metal.
- Packaging: 48 metres.

Part. S0814



■ Chain - guide profile

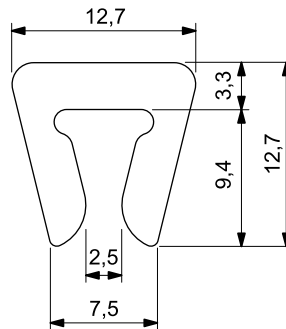

Material UHMWPE	Packaging metres	Code
White	30	629163

- Applicable to 3 to 4 mm thick sheet metal.
- Standard packaging: coil.

- **Material:** Polyethylene UHMWPE with molecular density 5.600.000 g/mol.
Characteristics: new material Polyethylene ULF™ brown red (UHMWPE): reduced friction coefficient, higher wear resistance.
- **Linear expansion coefficient:** $2 \times 10^{-4} \text{ } ^\circ\text{C}^{-1}$
Calculation of thermal expansion see Technical information.
- **Operating temperature Green Black:**
In air (- 40 to + 80 °C).
In hot water (+ 70 °C).
- **Operating temperature ULF™ brown red:**
In air (- 40 to + 45 °C).
In hot water (+ 45 °C).
- **Polyethylene ULF™ is FDA approved**
Polyethylene ULF™ complies with the Code of Federal Regulations Title 21, § 177.1520 "Olefin Polymers" of the Food and Drug Administration (FDA) of April 1, 2008.
- **Coefficient of friction between chain POM and wearstrip ULF™:** 0,08.
Note: for calculation of chain pull refer to Technical Support.
- **Position of guides.** See Technical information.

• **MatTop® modular chains**

Parallel wear strips.
Recommended with mediumlight loads.

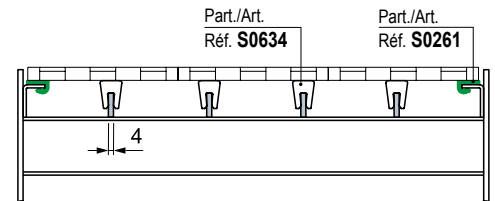

• **MatTop® modular chains**

Parallel wear strips.
Recommended with mediumlight loads.

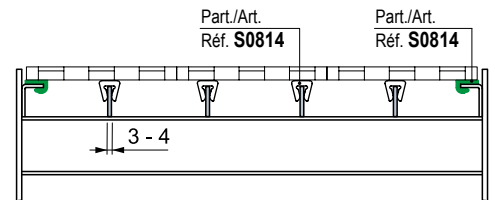

- **Material:** Polyethylene UHMWPE with molecular density 5.600.000 g/mol.
Characteristics: new material Polyethylene ULF™ brown red (UHMWPE): reduced friction coefficient, higher wear resistance.
- **Linear expansion coefficient:** $2 \times 10^{-4} \text{ } ^\circ\text{C}^{-1}$
Calculation of thermal expansion see Technical information.
- **Operating temperature Green Black:**
In air (- 40 to + 80 °C).
In hot water (+ 70 °C).
- **Operating temperature ULF™ brown red:**
In air (- 40 to + 45 °C).
In hot water (+ 45 °C).
- **Polyethylene ULF™ is FDA approved**
Polyethylene ULF™ complies with the Code of Federal Regulations Title 21, § 177.1520 "Olefin Polymers" of the Food and Drug Administration (FDA) of April 1, 2008.
- **Coefficient of friction between chain POM and wearstrip ULF™:** 0,08.
Note: for calculation of chain pull refer to Technical Support.
- **Position of guides.** See Technical information.

- **Use of part. S0742**
Ideal with TableTop® chains width 114,3 mm (K450).

Chain width 114,3 mm (K 450).

- **Use of part. S0674**
Ideal as intermediate support for wide chains.

TableTop® chains series 820 width 190,5 (K750).

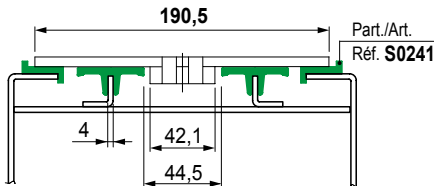

TableTop® double hinge chains series 821 width 304,8 (K1200).

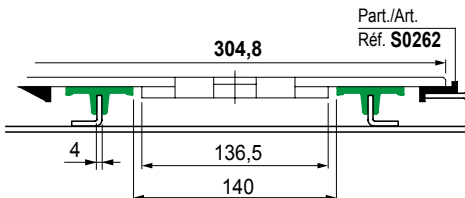

Chain - guide profile

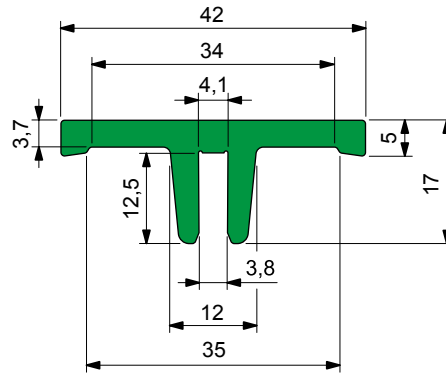

Part. S0674



Material	Length metres	Code
UHMWPE		
Green	3	675792

- Applicable to 4 mm thick sheet metal.
- Packaging: 24 metres.

Part. S0422



Chain - guide profile

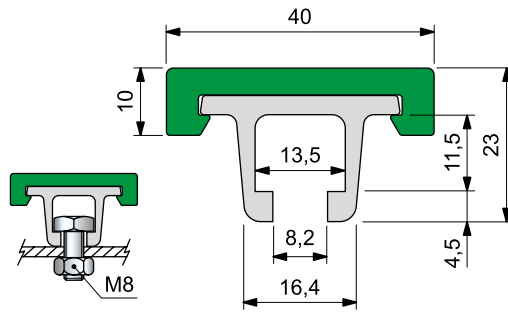

Assembly with M8 hexagon bolt

Metal profile material	Length metres	Code	Weight kg/m
Anodized aluminium	3	65248M	0,70
	6	65258M	

- Colour: green.
- Standard packaging: the plastic and metal profiles are supplied assembled.
- Packaging: 24 metres.

Part. S0369



Connecting bar

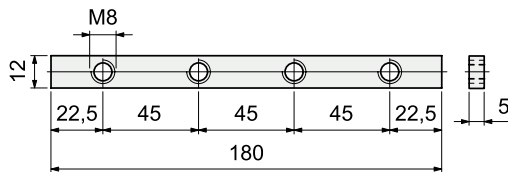

Material	Code	Weight kg
Zinc plated steel	69995	0,10

- Packaging: 8 pieces.

- **Material:** Polyethylene UHMWPE with molecular density 5.600.000 g/mol.
Characteristics: new material Polyethylene ULF™ brown red (UHMWPE): reduced friction coefficient, higher wear resistance.
- **Linear expansion coefficient:** $2 \times 10^{-4} \text{ } ^\circ\text{C}^{-1}$
Calculation of thermal expansion see Technical information.
- **Operating temperature Green Black:**
In air (- 40 to + 80 °C).
In hot water (+ 70 °C).
- **Operating temperature ULF™ brown red:**
In air (- 40 to + 45 °C).
In hot water (+ 45 °C).
- **Polyethylene ULF™ is FDA approved**
Polyethylene ULF™ complies with the Code of Federal Regulations Title 21, § 177.1520 "Olefin Polymers" of the Food and Drug Administration (FDA) of April 1, 2008.
- **Coefficient of friction between chain POM and wearstrip ULF™:** 0,08.
Note: for calculation of chain pull refer to Technical Support.
- **Position of guides.** See Technical information.

Deflection

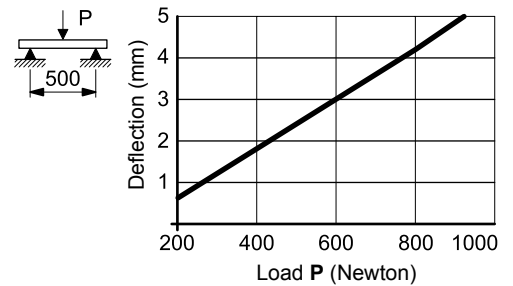

- **TableTop® chains** series 812 - 815 - 820 - 831 - 881TAB - 8811TAB - 879TAB - 880TAB

Chain width 82,5 mm (K 325) / Pitch 85 mm

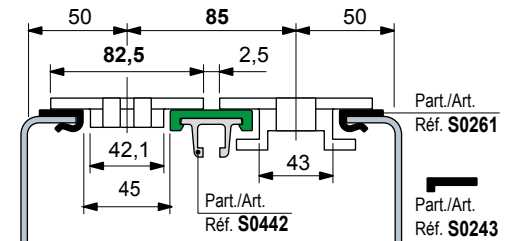

Chain width 82,5 mm (K 325) / Pitch 83,5 mm

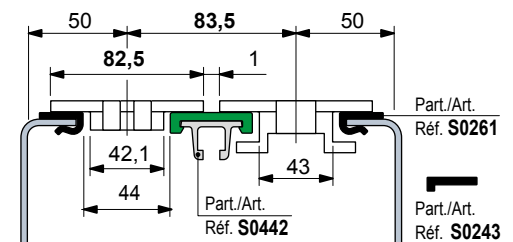

- **Assembly of Part. S0369**
Insert the guides and tighten the set screws.

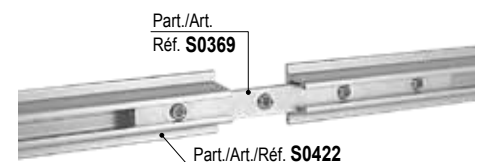

- **Material:** Polyethylene UHMWPE with molecular density 5.600.000 g/mol.
Characteristics: new material Polyethylene ULF™ brown red (UHMWPE): reduced friction coefficient, higher wear resistance.
- **Linear expansion coefficient:** $2 \times 10^{-4} \text{ } ^\circ\text{C}^{-1}$
Calculation of thermal expansion see Technical information.
- **Operating temperature Green Black:**
In air (- 40 to + 80 °C).
In hot water (+ 70 °C).
- **Operating temperature ULF™ brown red:**
In air (- 40 to + 45 °C).
In hot water (+ 45 °C).
- **Polyethylene ULF™ is FDA approved**
Polyethylene ULF™ complies with the Code of Federal Regulations Title 21, § 177.1520 "Olefin Polymers" of the Food and Drug Administration (FDA) of April 1, 2008.
- **Coefficient of friction between chain POM and wearstrip ULF™:** 0,08.
Note: for calculation of chain pull refer to Technical Support.
- **Position of guides.** See Technical information.

Chain - guide profile

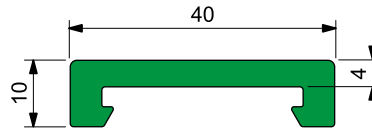

Part. S0885

Material	Length metres	Code
UHMWPE		
Green	6	68309

- Can be used in combination with Part. S0884 - S0368.
- Packaging: 48 metres.

Part. S0366



Chain - guide profile

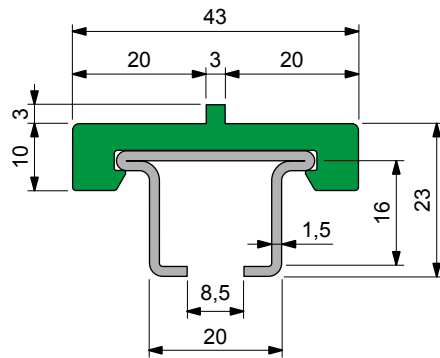

Metal profile material	Length metres	Code	Weight kg/m
Austenitic stainless steel	3	64056M	1,10

- Colour: green.
- Standard packaging: the plastic and metal profiles are supplied assembled.
- Packaging: 12 metres.

Part. S0367



Chain - guide profile

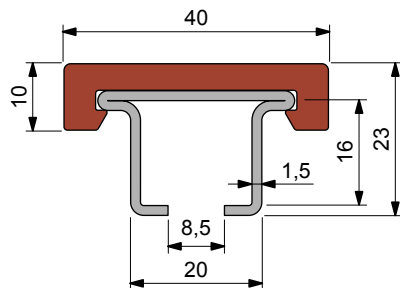

Metal profile material	Material UHMWPE	Length metres	Code	Weight kg/m
Austenitic stainless steel	Green	3	64046M	1,10
		6	69615M	
Ferritic stainless steel	Green	3	693272M	1,10
		6	693282M	

- Standard packaging: the plastic and metal profiles are supplied assembled.
- Packaging: 6 metres.
- Packaging: 3 metres.

- **Material:** Polyethylene UHMWPE with molecular density 5.600.000 g/mol.
Characteristics: new material Polyethylene ULF™ brown red (UHMWPE): reduced friction coefficient, higher wear resistance.
- **Linear expansion coefficient:** $2 \times 10^{-4} \text{ } ^\circ\text{C}^{-1}$
Calculation of thermal expansion see Technical information.
- **Operating temperature Green Black:**
In air (- 40 to + 80 °C).
In hot water (+ 70 °C).
- **Operating temperature ULF™ brown red:**
In air (- 40 to + 45 °C).
In hot water (+ 45 °C).
- **Polyethylene ULF™ is FDA approved**
Polyethylene ULF™ complies with the Code of Federal Regulations Title 21, § 177.1520 "Olefin Polymers" of the Food and Drug Administration (FDA) of April 1, 2008.
- **Coefficient of friction between chain POM and wearstrip ULF™:** 0,08.
Note: for calculation of chain pull refer to Technical Support.
- **Position of guides.** See Technical information.

Deflection of Part. S0366 - S0367 - S0368

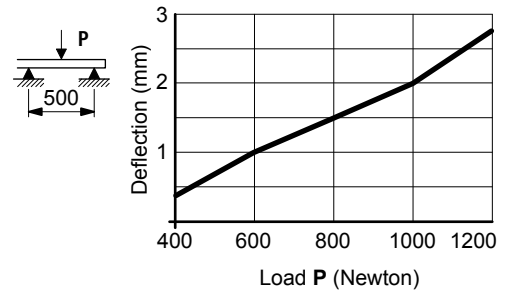

TableTop® chains series 812 - 815 - 820 - 831 - 881TAB - 8811TAB - 879TAB - 880TAB

Chain width 82,5 mm (K 325) / Pitch 88 mm

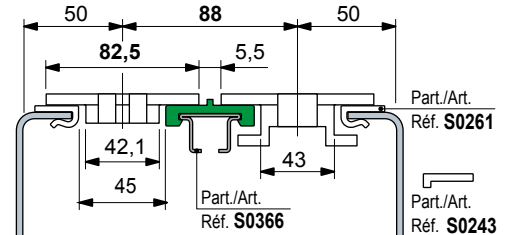

Chain width 82,5 mm (K 325) / Pitch 85 mm

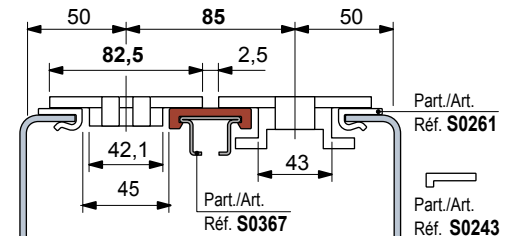

Chain width 82,5 mm (K 325) / Pitch 83,5 mm

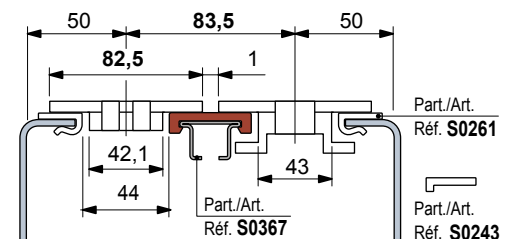

- **Material:** Polyethylene UHMWPE with molecular density 5.600.000 g/mol.
Characteristics: new material Polyethylene ULF™ brown red (UHMWPE): reduced friction coefficient, higher wear resistance.
- **Linear expansion coefficient:** $2 \times 10^{-4} \text{ } ^\circ\text{C}^{-1}$
Calculation of thermal expansion see Technical information.
- **Operating temperature Green Black:**
In air (- 40 to + 80 °C).
In hot water (+ 70 °C).
- **Operating temperature ULF™ brown red:**
In air (- 40 to + 45 °C).
In hot water (+ 45 °C).
- **Polyethylene ULF™ is FDA approved**
Polyethylene ULF™ complies with the Code of Federal Regulations Title 21, § 177.1520 "Olefin Polymers" of the Food and Drug Administration (FDA) of April 1, 2008.
- **Coefficient of friction between chain POM and wearstrip ULF™:** 0,08.
Note: for calculation of chain pull refer to Technical Support.
- **Position of guides.** See Technical information.

Chain - guide profile

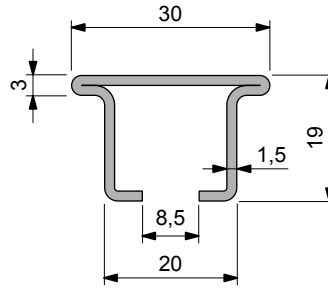

Metal profile material	Length metres	Code	Weight kg/m
Austenitic stainless steel	3	64066	0,90
Austenitic stainless steel	6	69645	
Ferritic stainless steel	3	693292	
Ferritic stainless steel	6	693302	

- Use: recommended with MatTop® chains in abrasive environment / high speed / high temperature.
- Packaging: 18 metres (in 6 m length)
- Packaging: 12 metres (in 3 m length)

Part. S0368



Chain - guide profile

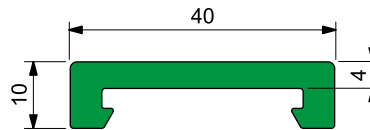

Material UHMWPE	Length metres	Code
Green	6	68309

- Can be used in combination with Part. S0368 - S0884.
- Packaging: 48 metres.

Part. S0885



Part. S0858

■ Hinge Joint

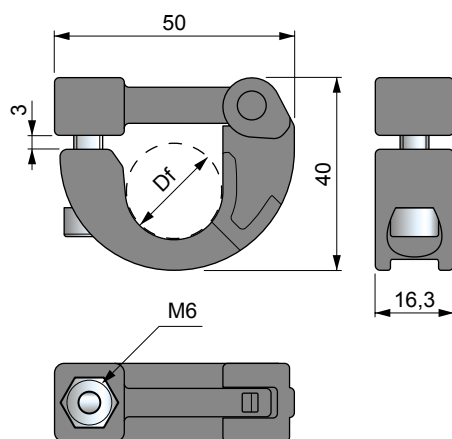

Bore dia. mm	Code	Weight kg
ø 20	645493	0,03

- Use: easy assembly of wear strips on tubes rods dia. 20 mm.
- Material: clamp in reinforced polyamide PA FV (black). Bolts and nuts in austenitic stainless steel.
- Packaging: 50 pieces.

• Use of Part S0858

Assembly the chain guide profiles Part. S0366 - S0367 - S0368 on rods dia. 20 mm.



No more drilling holes to assemble the profile, possibility to easily adjust the position of the guide, standardization of the 20 mm rod already used for the chain return section (with rollers).



Part. S0371



■ Mounting block

Chain width 114,3 mm (K 450) / Pitch 120 mm

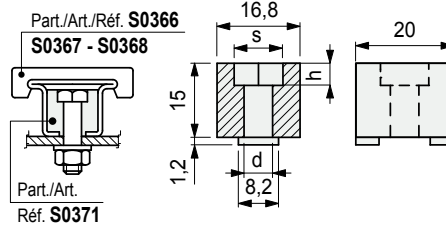
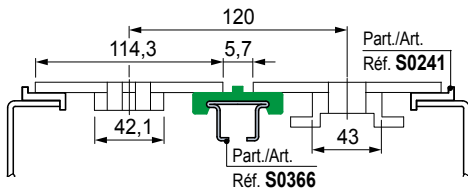

d mm	h mm	Hexagon s mm	Code
6,2 (for screws M6)	4,5	10,2	64026
8,1 (for screws M8)	6	13,2	61056

- Use: easy assembly of wear strips on frame. Assembly with M6 or M8 hexagon bolt.
- Material: reinforced polyamide PA FV (black).
- Packaging: 50 pieces.

Chain width 152,4 mm (K 600) / Pitch 158 mm

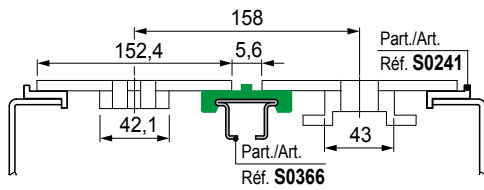

• MatTop® modular chains

Parallel wear strips.
Recommended with medium light loads.

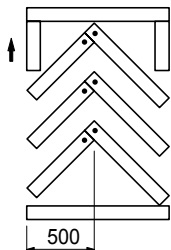
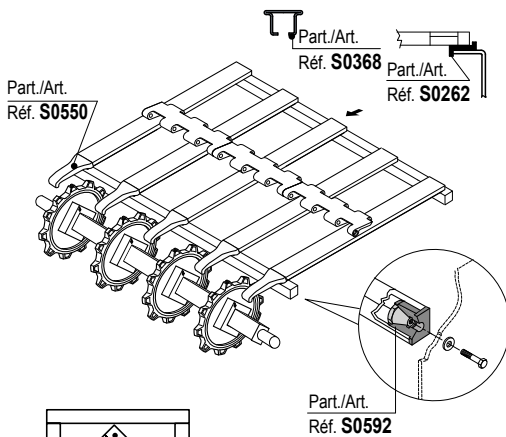
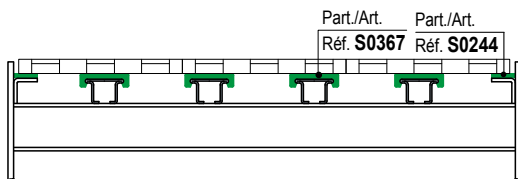

CHEVRON pattern.
Recommended with high loads
(accumulation tables).
Chain wear is evenly distributed
throughout the width.

Part. S0550



Chain inlet guide shoe (centre)

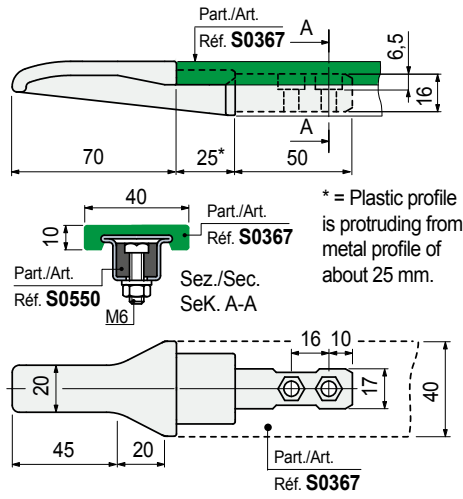

Code	Weight kg
689491	0,042

- Use: can be used in combination with Part. S0367.
- Material: polyamide PA (black).
- Packaging: 50 pieces.

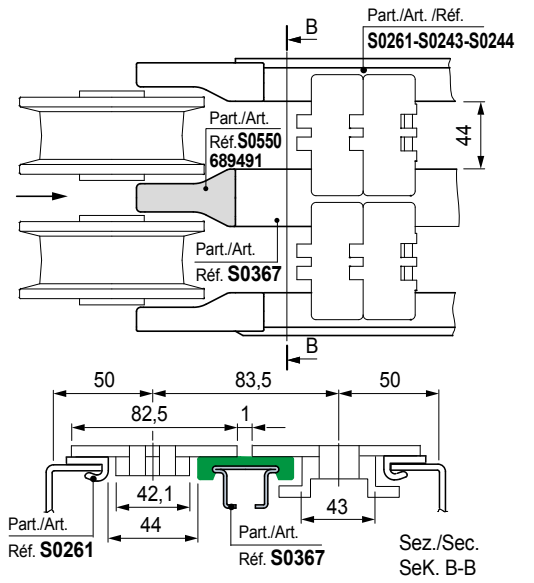

- Example of use of Part. 550 in a MatTop® conveyor.

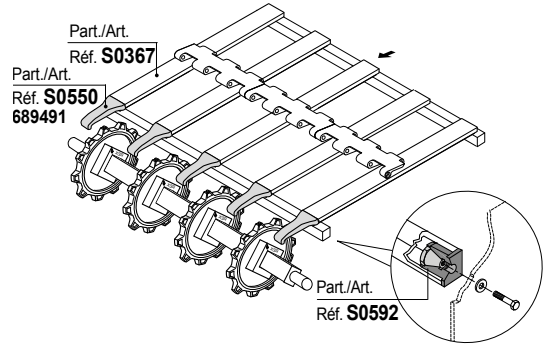

Positioning

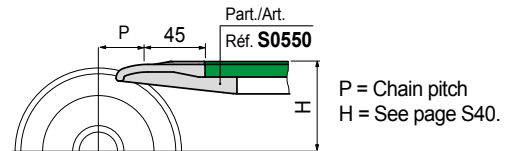

Part. S0768



Chain - guide profile

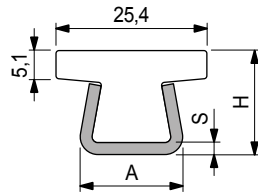

S	H	A
mm	mm	mm
1,5	17	16
2	17,5	17

Thickness S mm	Metal profile material	Length metres	Code	Weight kg/m
1,5	Austenitic stainless steel	3	609083N	0,63
2	Austenitic stainless steel	3	609113N	0,74

- Colour: white.
- Min. curvature radius: 160 mm.
- Linear expansion coefficient: $4 \times 10^{-5} \text{ } ^\circ\text{C}^{-1}$.
- Calculation of thermal expansion see Technical information.
- Packaging: 24 metres.

Part. S0767



Chain - guide profile

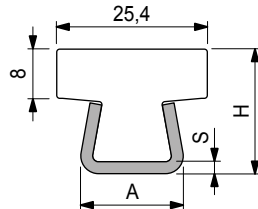

S	H	A
mm	mm	mm
1,5	20,5	16
2	21	17

Thickness S mm	Metal profile material	Length metres	Code	Weight kg/m
2	Austenitic stainless steel	3	609063N	0,82

- Colour: white.
- Min. curvature radius: 160 mm.
- Linear expansion coefficient: $4 \times 10^{-5} \text{ } ^\circ\text{C}^{-1}$.
- Calculation of thermal expansion see Technical information.
- Packaging: 24 metres.

- **Material:** Polyethylene UHMWPE with molecular density 5.600.000 g/mol.
Characteristics: new material Polyethylene ULF™ brown red (UHMWPE): reduced friction coefficient, higher wear resistance.
- **Operating temperature White:**
In air (- 40 to + 80 °C).
In hot water (+ 70 °C).
- **Operating temperature ULF™ brown red:**
In air (- 40 to + 45 °C).
In hot water (+ 45 °C).
- **Polyethylene ULF™ is FDA approved**
Polyethylene ULF™ complies with the Code of Federal Regulations Title 21, § 177.1520 "Olefin Polymers" of the Food and Drug Administration (FDA) of April 1, 2008.
- **Coefficient of friction between chain POM and wearstrip ULF™:** 0,08.
Note: for calculation of chain pull refer to Technical Support.
- **Position of guides.** See Technical information.

Deflection of Part. S0223 - S0310 - S0356

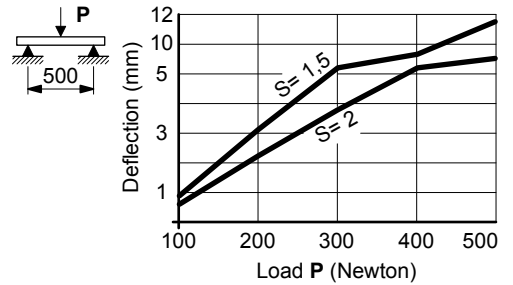

TableTop® chains series 812 - 815 - 820 - 831 - 881TAB - 8811TAB - 879TAB - 880TAB

Chain width 82,5 mm (K 325) / Pitch 88 mm

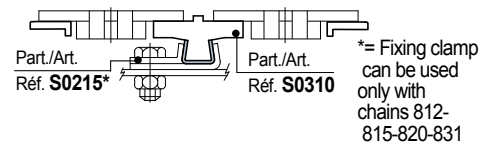
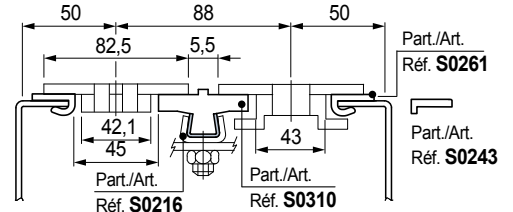

Chain width 82,5 mm (K 325) / Pitch 85 mm

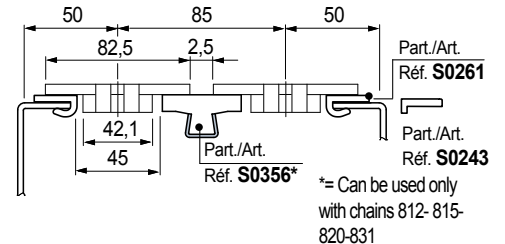

Chain width 82,5 mm (K 325) / Pitch 83,5 mm

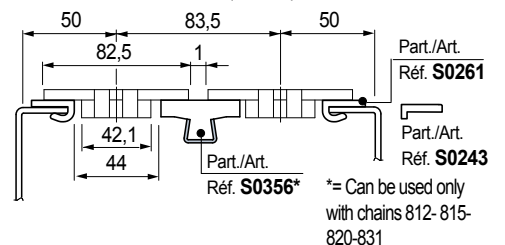

- **Material:** Polyethylene UHMWPE with molecular density 5.600.000 g/mol.
Characteristics: new material Polyethylene ULF™ brown red (UHMWPE): reduced friction coefficient, higher wear resistance.
- **Operating temperature White:**
In air (- 40 to + 80 °C).
In hot water (+ 70 °C).
- **Operating temperature ULF™ brown red:**
In air (- 40 to + 45 °C).
In hot water (+ 45 °C).
- **Polyethylene ULF™ is FDA approved**
Polyethylene ULF™ complies with the Code of Federal Regulations Title 21, § 177.1520 "Olefin Polymers" of the Food and Drug Administration (FDA) of April 1, 2008.
- **Coefficient of friction between chain POM and wearstrip ULF™:** 0,08.
Note: for calculation of chain pull refer to Technical Support.
- **Position of guides.** See Technical information.

- **Head joint**
Head joint shall be made with a 45° cut to avoid steps and guarantee chain smooth movement. With temperature increase it is necessary to leave a gap wide enough to allow for thermal elongation of plastic parts.

• MatTop® modular chain

Parallel wear strip.
Recommended with medium-light loads.

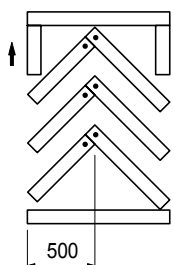
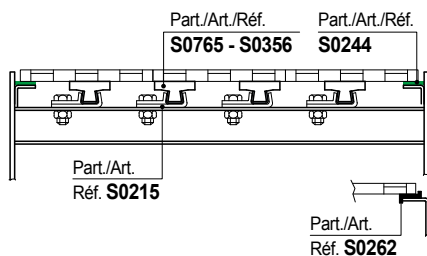

CHEVRON pattern.
Recommended with high loads (accumulation tables)
Chain wear is evenly distributed throughout the width.

■ Chain - guide profile

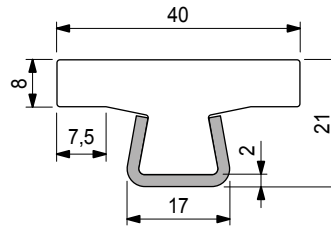

Colour	Length metres	Code	Weight kg/m
White	3	61605	0,89
	6	61615	

- Material: metal profile austenitic stainless steel.
- Linear expansion coefficient: $4 \times 10^{-5} \text{ } ^\circ\text{C}^{-1}$.
- Calculation of thermal expansion see Technical information.
- Packaging: 24 metres.

Part. S0356



Chain - guide profile

S	H	A
mm	mm	mm
1,5	20,5	16
2	21	17

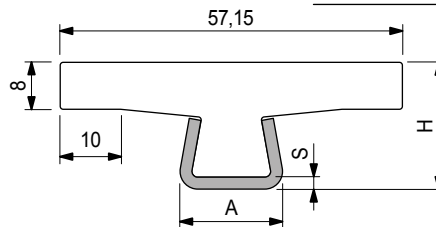

Thickness S mm	Metal profile material	Length metres	Code	Weight kg/m
1,5	Austenitic stainless steel	3	608943N	0,95
2	Austenitic stainless steel	6	608983N	1,06

- Colour: white.
- Min. curvature radius: 200 mm.
- Linear expansion coefficient: $4 \times 10^{-5} \text{ } ^\circ\text{C}^{-1}$.
- Calculation of thermal expansion see Technical information.
- Packaging: 24 metres.

Part. S0765



Part. S0766



Chain - guide profile

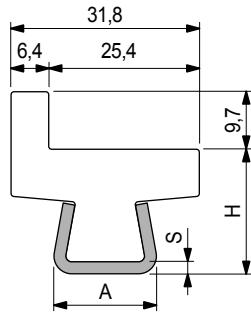

S	H	A
mm	mm	mm
1,5	20,5	16
2	21	17

Thickness S mm	Metal profile material	Length metres	Code	Weight kg/m
2	Austenitic stainless steel	3	609013N	0,93

- Colour: white.
- Linear expansion coefficient: $4 \times 10^{-5} \text{ } ^\circ\text{C}^{-1}$.
- Calculation of thermal expansion see Technical information.
- Packaging: 24 metres.

- **Material:** Polyethylene UHMWPE with molecular density 5.600.000 g/mol.
Characteristics: new material Polyethylene ULF™ brown red (UHMWPE): reduced friction coefficient, higher wear resistance.
- **Operating temperature White:**
In air (- 40 to + 80 °C).
In hot water (+ 70 °C).
- **Operating temperature ULF™ brown red:**
In air (- 40 to + 45 °C).
In hot water (+ 45 °C).
- **Polyethylene ULF™ is FDA approved**
Polyethylene ULF™ complies with the Code of Federal Regulations Title 21, § 177.1520 "Olefin Polymers" of the Food and Drug Administration (FDA) of April 1, 2008.
- **Coefficient of friction between chain POM and wearstrip ULF™:** 0,08.
Note: for calculation of chain pull refer to Technical Support.
- **Position of guides.** See Technical information.

- **Head joint**
Head joint shall be made with a 45° cut to avoid steps and guarantee chain smooth movement. With temperature encrease it is necessary to leave a gap wide enough to allow for thermal elongation of plastic parts.

MatTop® modular chain

Parallel wear strip.
Recommended with medium-light loads.

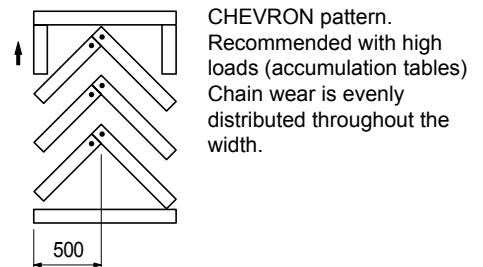
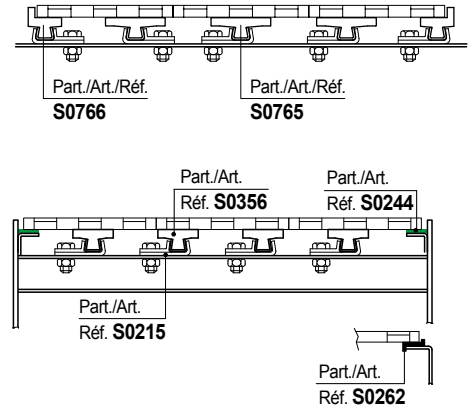

CHEVRON pattern.
Recommended with high loads (accumulation tables)
Chain wear is evenly distributed throughout the width.

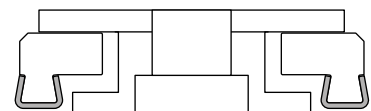

Part. S0223

- **Material:** Polyethylene UHMWPE with molecular density 5.600.000 g/mol.
Characteristics: new material Polyethylene ULF™ brown red (UHMWPE): reduced friction coefficient, higher wear resistance.
- **Operating temperature White:**
In air (- 40 to + 80 °C).
In hot water (+ 70 °C).
- **Operating temperature ULF™ brown red:**
In air (- 40 to + 45 °C).
In hot water (+ 45 °C).
- **Polyethylene ULF™ is FDA approved**
Polyethylene ULF™ complies with the Code of Federal Regulations Title 21, § 177.1520 "Olefin Polymers" of the Food and Drug Administration (FDA) of April 1, 2008.
- **Coefficient of friction between chain POM and wearstrip ULF™:** 0,08.
Note: for calculation of chain pull refer to Technical Support.
- **Position of guides.** See Technical information.

• Use of Part. S0223

ANSI 60 American series roller chain (pitch 19,05 mm, roller Dia. 11,91 mm, internal width 12,7 mm).

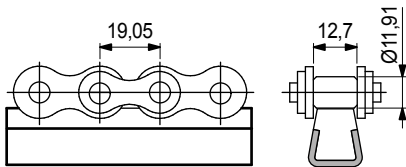

• PlateTop chain series 1874 - 4874 - 1873

Chain width 82,5 mm (K325), 114,3 mm (K450), 152,4 mm (K600)

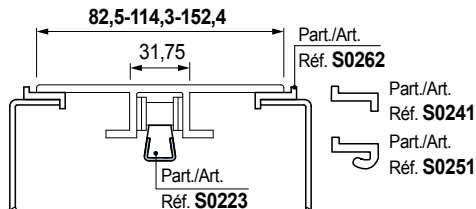

Chain width 254 mm (K1000), 304,8 mm (K1200)

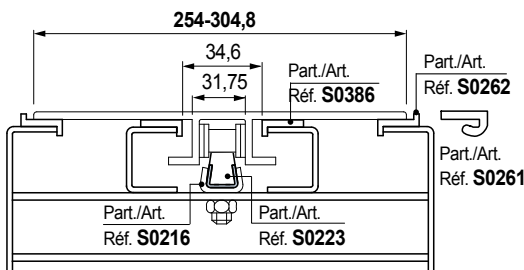

■ Chain - guide profile

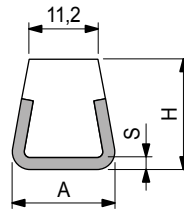

S	H	A
mm	mm	mm
1,5	17,5	16
2	18	17



Thickness S mm	Metal profile material	Length metres	Code	Weight kg/m
1,5	Austenitic stainless steel	3	61031	0,54
	Zinc plated steel	3	63971	

- Colour: white.
- Linear expansion coefficient: $4 \times 10^{-5} \text{ } ^\circ\text{C}^{-1}$.
- Calculation of thermal expansion see Technical information.
- Packaging: 24 metres

Part. S0903



■ **ViseClamp™**

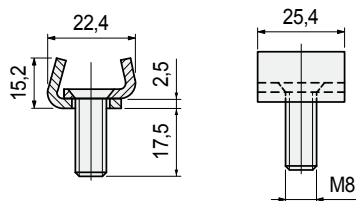

Use	Code
For guides width S = 2	656001N

- Material: austenitic stainless steel.
- Packaging: 50 pieces.

• **Assembly of Part. S0903**

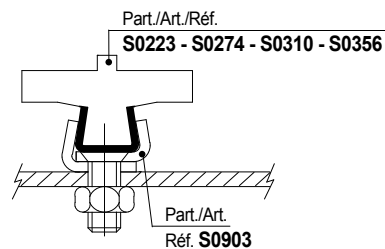

Part. S0902



■ **ViseSplice™**

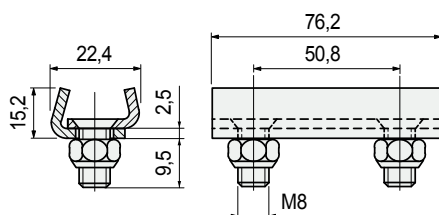

Use	Code
For guides width S = 2	656041N

- Material: austenitic stainless steel.
- Self-locking nut.
- Packaging: 50 pieces.

• **Assembly of Part. S0902**

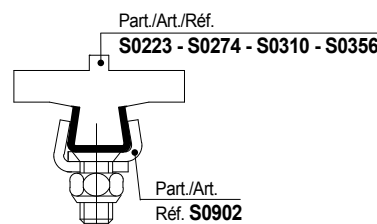

Chain - Guide Profiles

for Part. S0223 - S0274 - S0310 - S0356

• Assembly of Part. S0215

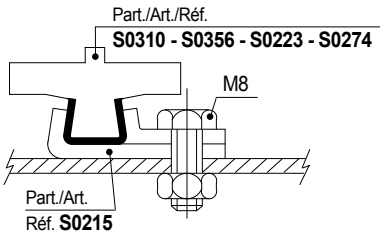

■ Clamp

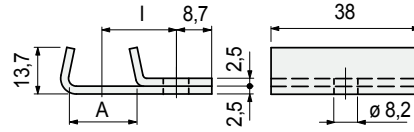

Use	A mm	I mm	Code
For guides width S = 1,5	16	20,5	60121N
For guides width S = 2	17	20	65976N

- Use: easy assembly of guide profiles Part. S0310 - S0356 - S0223 - S0274.
- Material: austenitic stainless steel.
- Packaging: 50 pieces.

Part. S0215



• Assembly of Part. S0275

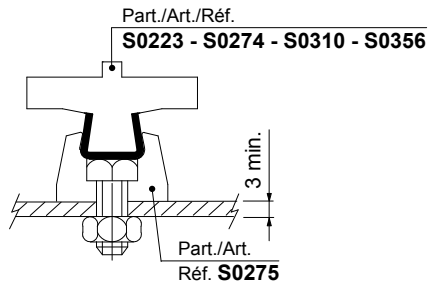

■ Clamp

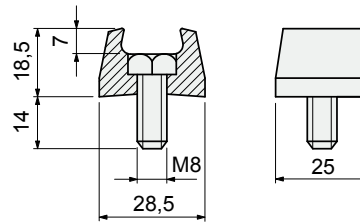

Use	Code
For Part. S0223 (width S = 1,5 e 2) S0274 - S0310 - S0356	66811

- Use: easy assembly of guide profiles Part. S0310 - S0356 - S0223 - S0274.
- Material: body in acetal resin POM (black), bolt in austenitic stainless steel.
- Packaging: 50 pieces.

Part. S0275



• Positioning

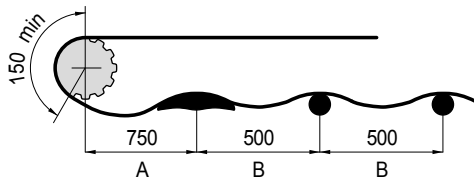

$$A = 1,5 \cdot B$$

• Assembly

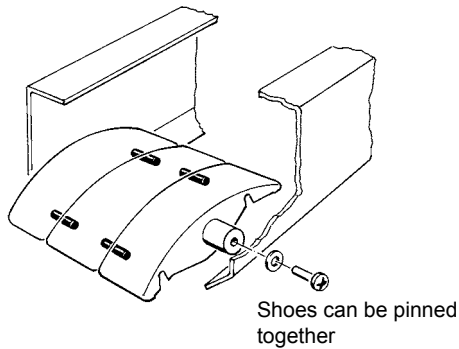
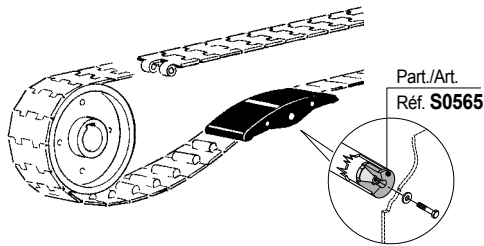

• TableTop® chains / PlateTop chains

Chain width 82,5 mm (K 325)

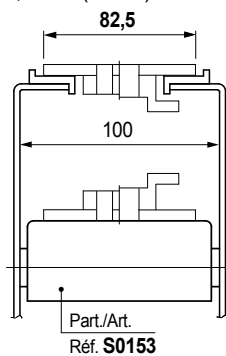

Chain width 82,5mm (K 325) / Pitch 88mm

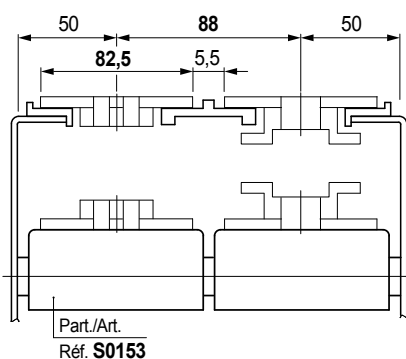

■ Wear shoe

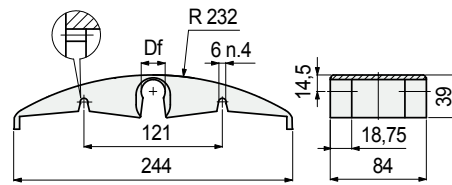

Shaft dia. mm	Bore dia. Df mm	Materiale	Code
18	18,5	Polyethylene PE (green)	608692N1
20	20,5	Polyethylene PE (green)	684231N1

- New UNL™ low noise material is recommended only with LBP chains.
- PE polyethylene (green) version is recommended with plastic chains and metal chains.
- PA polyamide (black) version is recommended only with metal chains.
- The use of only one wear shoe after the catenary is recommended, with the exception of LBP chains that can run on more wear shoes.
- Packaging: 15 pieces.

Part. S0153



Snap-on assembly

Chain width 82,5mm (K 325) / Pitch 85mm

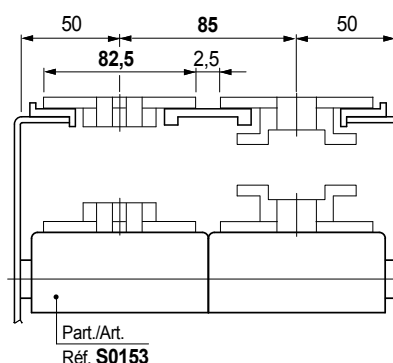

Part. S0073



Dia. 42,5 mm

Roller

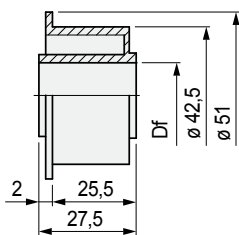

Shaft dia. mm	Bore dia. Df mm	Code
20	20,5	50680

- Material: polyethylene PE (black).
- Packaging: 48 metres.

Part. S0126



Separator

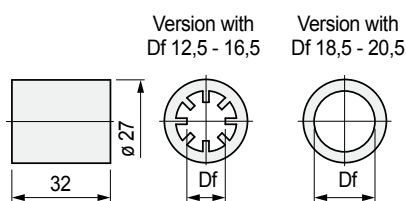

Shaft dia. mm	Bore dia. Df mm	Code
20	20,5	62520

- Material: polyethylene PE (black).
- Packaging: 48 metres.

TableTop® chains/PlateTop chains

Chain width 82,5 mm (K 325)

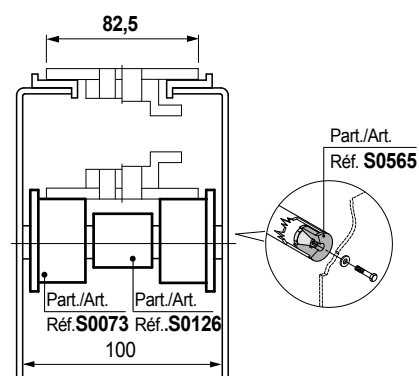

Chain width 114,3 mm (K 450)

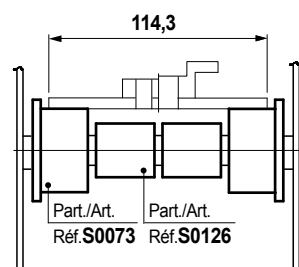

Chain width 82,5 mm (K 325) / Pitch 88 mm

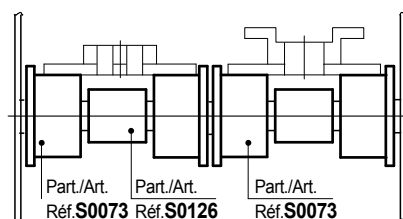
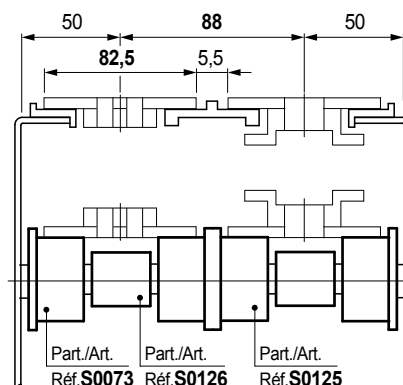

Chain width 114,3 mm (K 450) / Pitch 120 mm

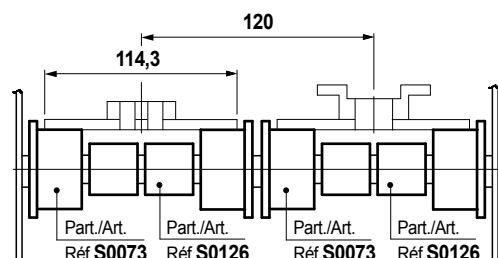

Chain width 82,5 mm (K 325) / Pitch 85 mm

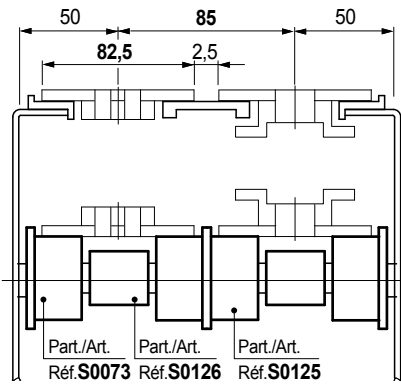

Chain width 82,5 mm (K 325) / Pitch 83,5 mm

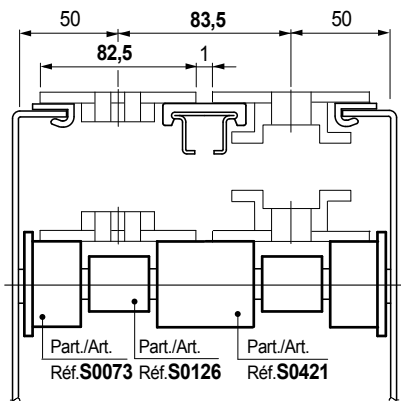

Chain width 87 mm (K 343) / Pitch 88 mm

Roller

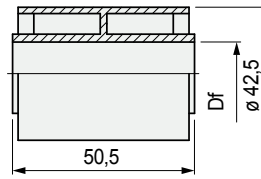

Shaft dia. mm	Bore dia. Df mm	Code
20	20,5	63888

- Material: polyethylene PE (black).
- Packaging: 48 metres.

Part. S0421



Dia. 42,5 mm

Part. S0782



Dia. 50 mm

Double roller

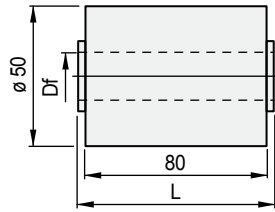

shaft dia.		Bore dia.		Code	
mm	inch	Df	mm	L = 82	L = 84,5
20	3/4	20,5		620613	620633

Version PE (Black)

20	3/4	20,5	620613	620633
----	-----	------	--------	--------

- Characteristics: completely closed design.
- Version in UNL™ low noise material.
- Colour: UNL™ (aubergine), polyethylene PE (black).
- Packaging: 48 pieces.

Part. S0787



For Part. S0782

Guide flange

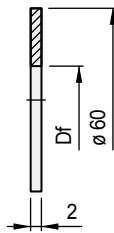

Material	shaft dia.		Bore dia.		Code
	mm	inch	Df	mm	
Polyethylene PE (black)	20	3/4	20,2		620673

- Assembly: to be applied to roller Part. S0782.
- Packaging: 100 pieces.

Chain width 82,5 mm (K325)

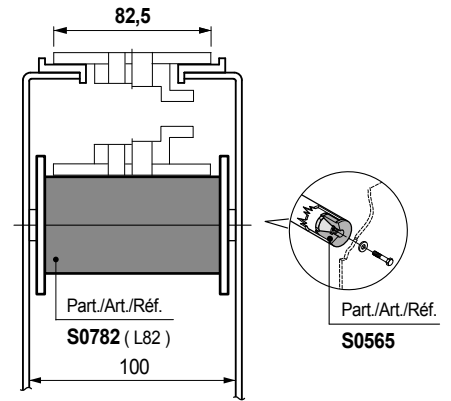

Chain width 82,5 mm (K325) / Pitch 85 mm

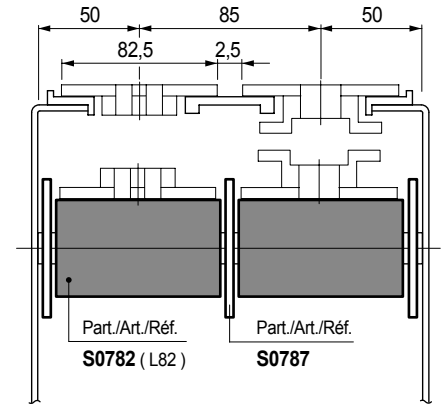

Chain width 84 mm pitch 85 mm

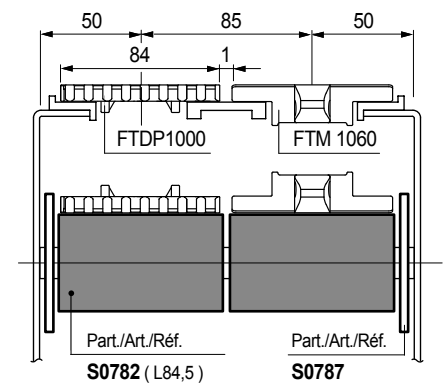

MatTop® modular chains

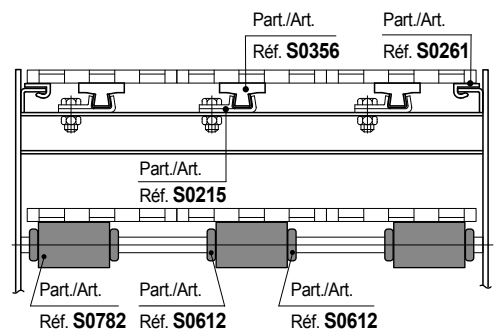

Part. S0826



Dia. 45 mm

Double roller (with rubber surface)

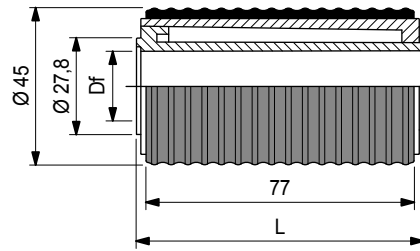

Shaft dia. mm	Bore dia. Df mm	Code	
		L = 82,5	L = 84,5
16	16,5	632063	632083
20	20,5	632073	632093

- Characteristics: completely closed design. Rubber surface for less noise even in high speed conveyors. Hub in acetal for low friction.
- Material: roller in polyethylene PE (white). Surface in thermoplastic rubber (grey). 70 shore hardness.
- Packaging: 48 pieces.

Part. S0827



Guide flange

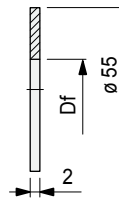

Shaft dia. mm	inch	Bore dia. Df mm	Code
			16
20	3/4	20,2	632113

- Material: polyethylene PE (black).
- Packaging: 100 pieces.

Chain width 82,5 mm (K325)

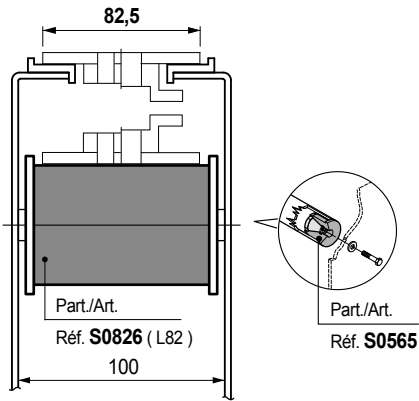

Chain width 82,5 mm (K325) / Pitch 85 mm

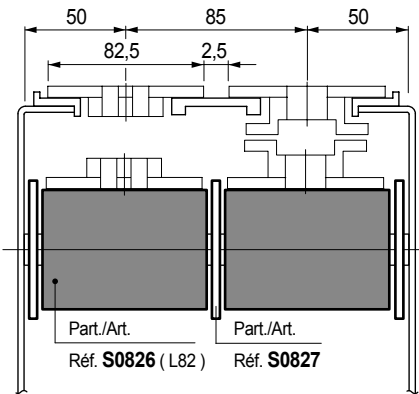

Chain width 84 mm pitch 85 mm

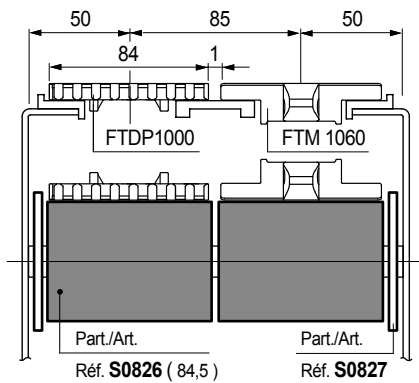

MatTop® modular chains

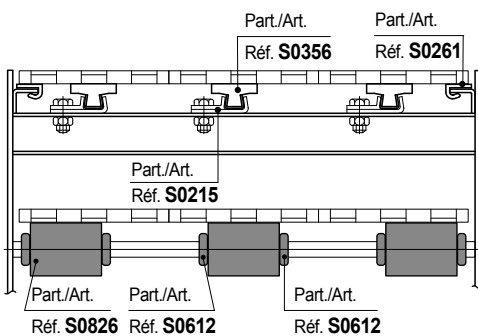

Part. **S0556**



Dia. 60 mm

Roller

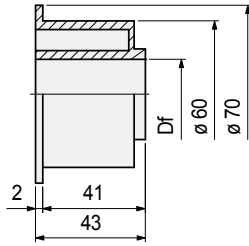

Shaft dia. mm	Bore dia. Df mm	Code
20	20,5	695251

- Material: polyethylene PE (black).
- Packaging: 48 pieces.

Part. **S0554**



Dia. 60 mm

Roller

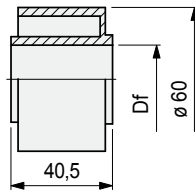

Shaft dia. mm	Bore dia. Df mm	Code
20	20,5	695171

- Material: polyethylene PE (black).
- Packaging: 48 pieces.

• TableTop® chains / PlateTop chains

Chain width 82,5 mm (K 325)

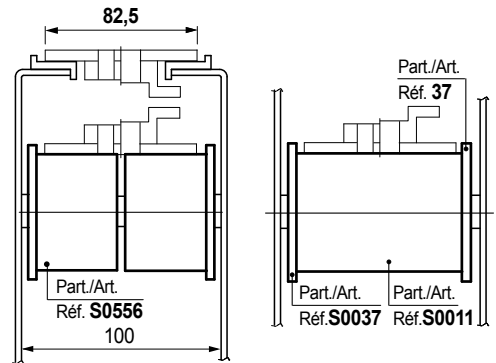

Chain width 82,5 mm (K325) - 101,6 mm (K400)

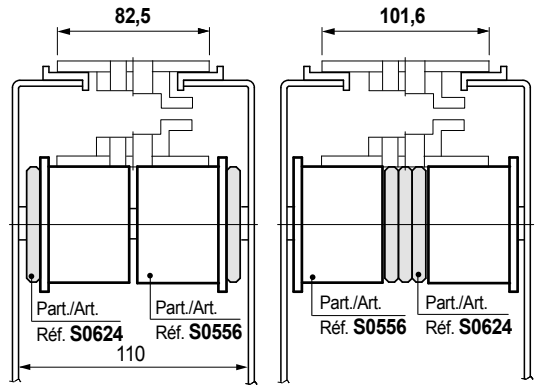

Chain width 114,3 mm (K 450)

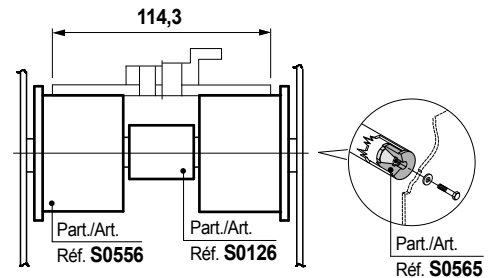

Chain width 82,5 mm (K 325) / Pitch 88 mm

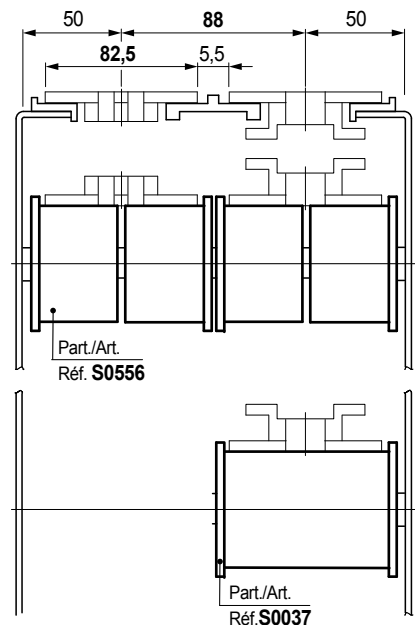

• TableTop® chains / PlateTop chains

Chain width 82,5 mm (K 325)

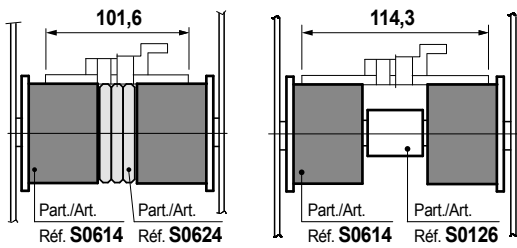
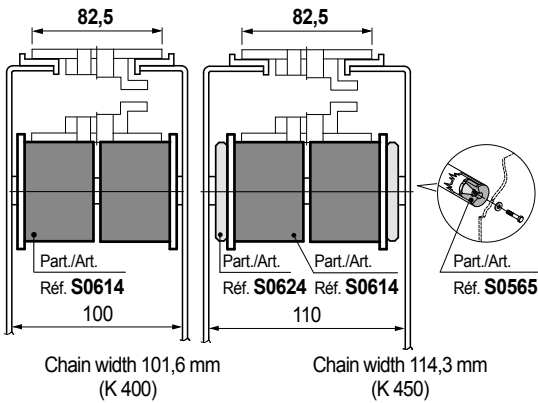

Chain width 82,5 mm (K 325) / Pitch 85 mm

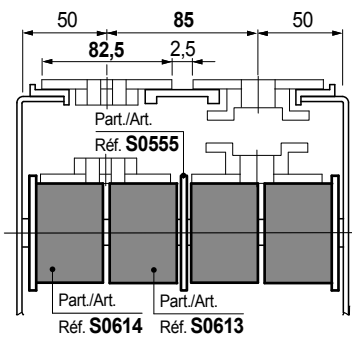

Chain width 82,5 mm (K 325) / Pitch 83,5 mm

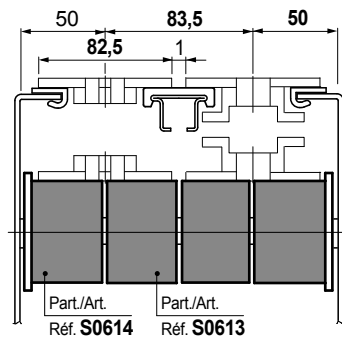

Chain width 114,3 mm (K 450) / Pitch 120 mm

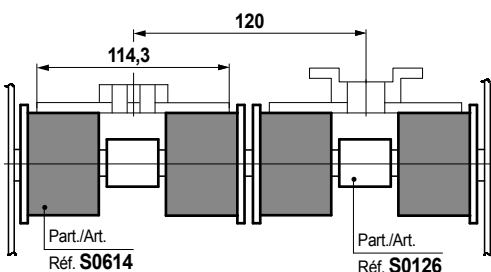

■ Roller (with rubber surface)

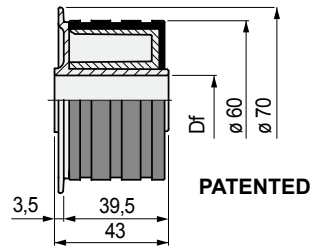

Shaft dia.		Bore dia.		Code
mm	inch	Df	mm	
12,7	1/2	13,2	632482	
16	5/8	16,5	615392	
19,05	3/4	19,5	635152	
20	-	20,5	615412	

- Characteristics: completely closed design. Rubber surface for less noise even in high speed conveyors. Hub in acetal for low friction.
- Material: roller in acetal POM (black). Surface in thermoplastic rubber (grey).
- Packaging: 48 pieces.

Part. S0614



Dia. 60 mm

■ Roller (with rubber surface)

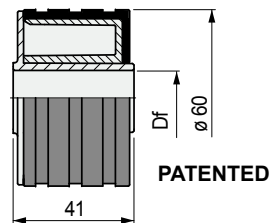

Shaft dia.		Bore dia.		Code
mm	inch	Df	mm	
12,7	1/2	13,2	632472	
16	5/8	16,5	615352	
19,05	3/4	19,5	635142	
20	-	20,5	615372	

- Characteristics: completely closed design. Rubber surface for less noise even in high speed conveyors. Hub in acetal for low friction.
- Material: roller in acetal POM (black). Surface in thermoplastic rubber (grey).
- Packaging: 48 pieces.

Part. S0613



Dia. 60 mm

Part. S0758



Dia. 60 mm

Double roller

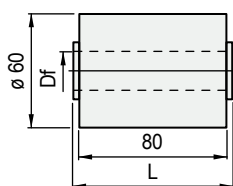

shaft dia.		Bore dia.		Code	
mm	inch	Df	mm	L = 82	L = 84,5
Version PE (Black)					
20	-	20,5		620713	620343

- Characteristics: completely closed design.
- Polyethylene PE (black).
- Packaging: 48 pieces.

Part. S0555

For Part. S0554
Part. S0613
Part. S0758



Guide flange

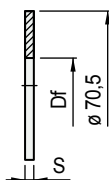

Shaft dia.		Bore dia.		Code	
mm	inch	Df	mm	S = 2	
20	3/4	20,2		695211	

- Material: Polyethylene PE (black).
- Packaging: 100 pieces.

Chain width 82,5 mm (K 325)

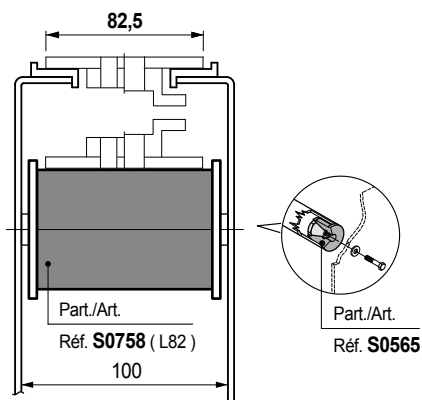

Chain width 82,5 mm (K 325) / Pitch 85 mm

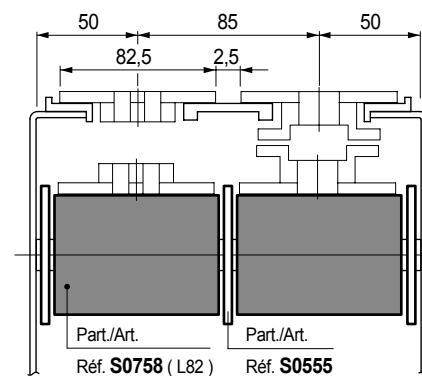

Chain width 84 mm (K 325) / Pitch 85 mm

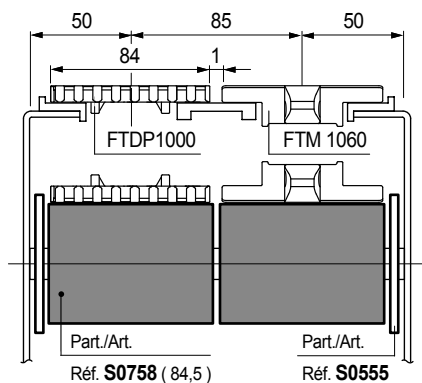

MatTop® modular chains

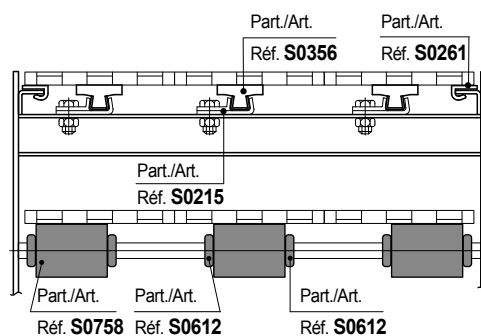

Part. S0657



Dia. 60 mm

Double roller (with rubber surface)

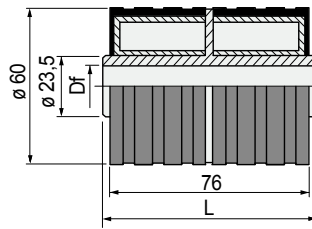

PATENTED

Shaft dia. mm	inch	Bore dia. Df mm	Code	
			L = 82	L = 84,5
12,7	1/2	13,2	656982	-
16	5/8	16,5	657002	-
18	-	18,5	657012	-
19,05	3/4	19,5	656692	-
20	-	20,5	657022	608283

- Characteristics: completely closed design. Rubber surface for less noise even in high speed conveyors. Hub in acetal for low friction.
- Material: roller in acetal POM. Surface in thermoplastic rubber (black). 70 shore hardness
- Packaging: 48 pieces.

Chain width 82,5 mm (K 325)

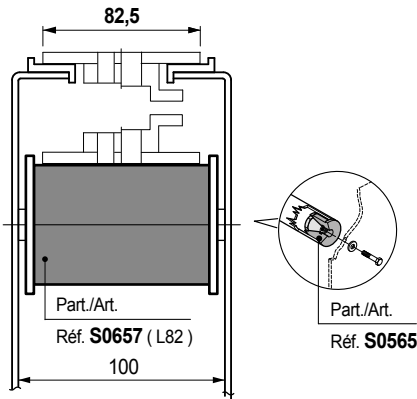

Chain width 82,5 mm (K 325) / Pitch 85 mm

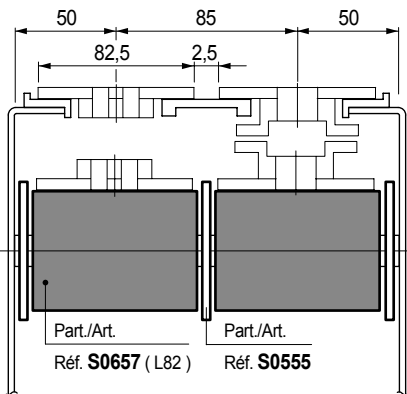

Chain width 84 mm (K 325) / Pitch 85 mm

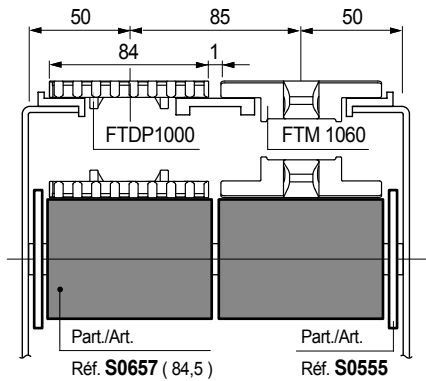

MatTop® modular chains

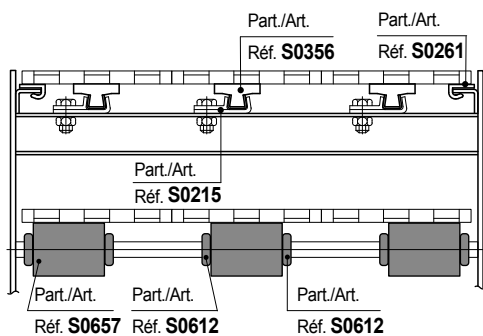

Part. S0729



Chain return guide

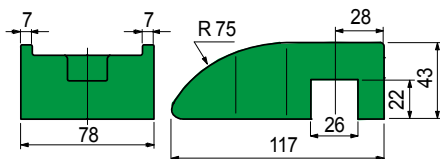

Material	Code	Weight kg
Polyethylene PE (green)	697662	0,10

- New design offers less and more uniform wear of chains and better cleanability.
- PE polyethylene (green) version is recommended with plastic chains and metal chains.
- PA polyamide (black) version is recommended only with metal chains.
- Packaging: 25 pieces.

Part. S0524



Sliding profile

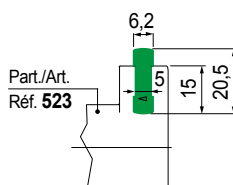

Material	Code
Polyethylene PE (green) 1.000.000	643501

- Assembly: Applicable to spacers Part. S0523. Snap-on assembly.
- Standard packaging: coil.
- Packaging: 70 metres.

Assembly Part. S0729

Assembly: press-fit. Interference fixed.
For assembly schemes see page S40.

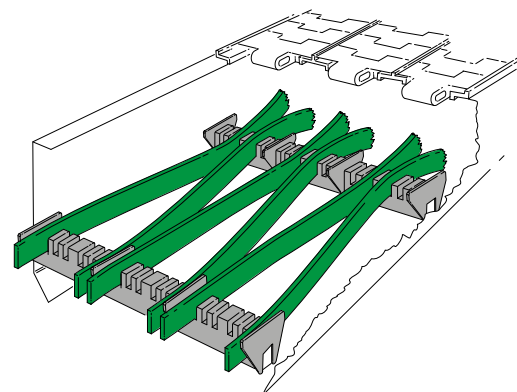
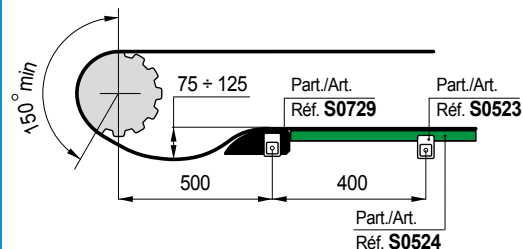
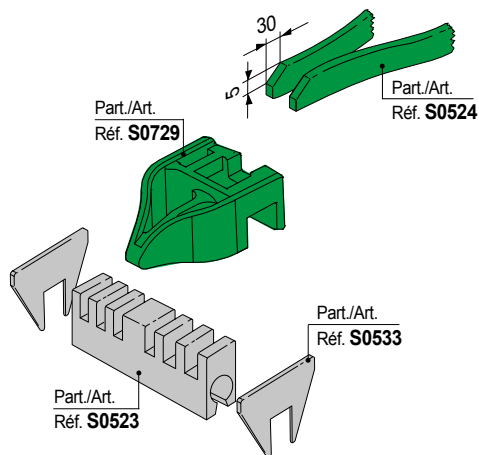

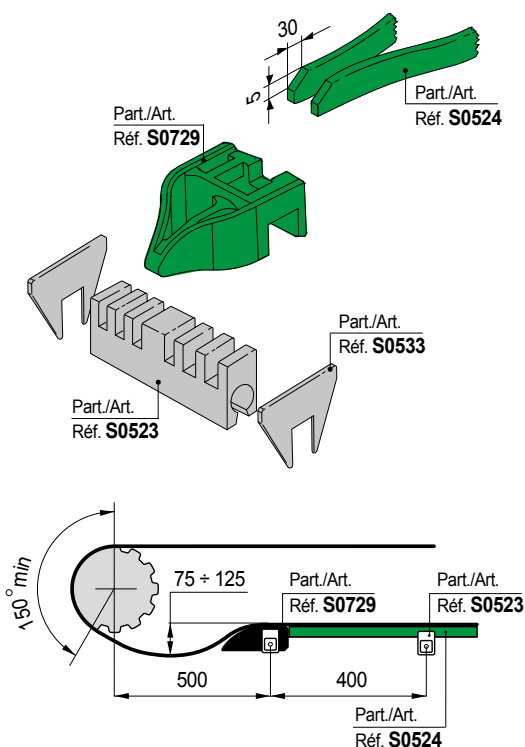

■ Spacer for square profiles

Version width L 84 mm

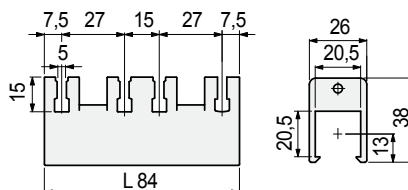

Quare shaft mm	Width L mm	Code	Weight Kg
20 x 20	L 84	643451	0,03

- Material: Polyamide PA (black).
- Packaging: 50 pieces.

Part. S0523



■ Spacer for round profile

Version width L 84 mm

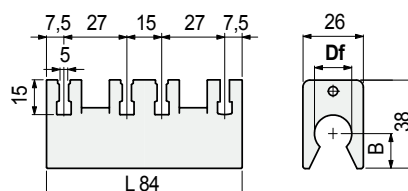

Version width L 116 mm

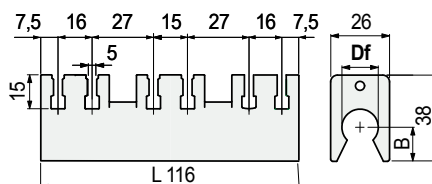

Width L mm	Bore dia. Df mm	inch	Code	B mm	Weight Kg
L 84	20	-	643491	13	0,04
L 116	20	-	692132	13	0,05

- Material: Polyamide PA (black).
- Packaging: 50 pieces.

Part. S0523



Serpentine Guides for Chain Return

for Part. S0523

Part. S0533

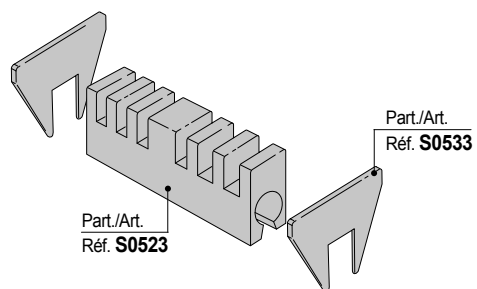

■ Striker

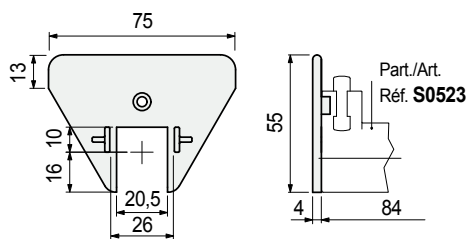

Code

Weight
kg

672801

0,01

- Assembly: Applicable to spacers Part. S0523. Snap-on assembly.
- Material: polyamide PA (black).
- Packaging: 100 pieces.

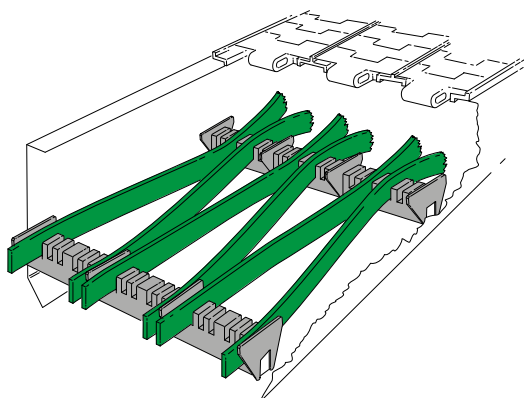

Assembly schemes for

Part: S0729
S0523
S0533
S0524

• Chain width 82,5 mm (K325)

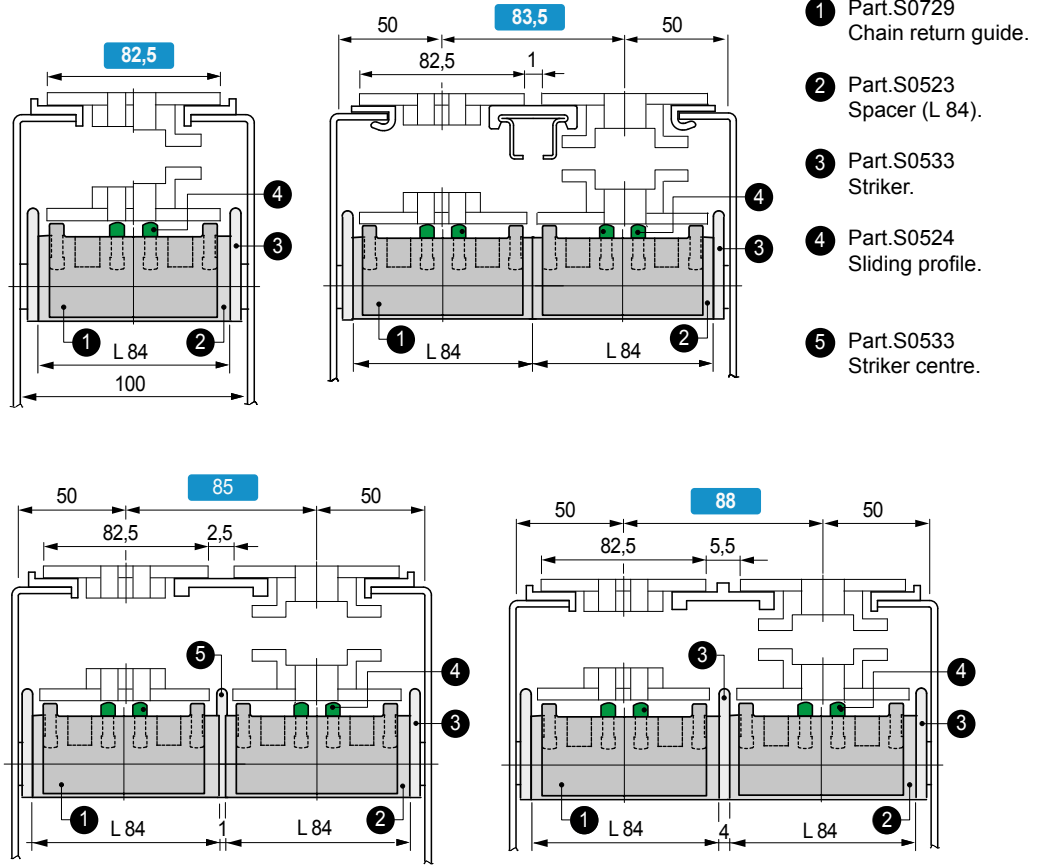

• Chain width 114,3 mm (K450)

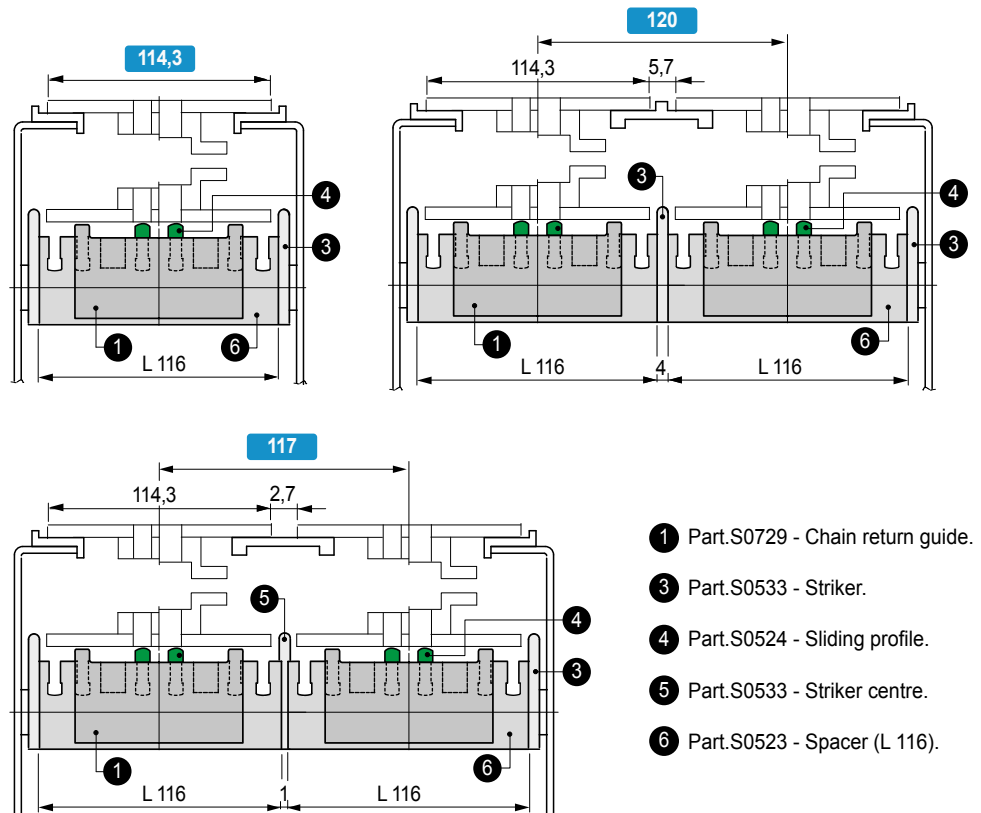

- 1 Part.S0729 - Chain return guide.
- 3 Part.S0533 - Striker.
- 4 Part.S0524 - Sliding profile.
- 5 Part.S0533 - Striker centre.
- 6 Part.S0523 - Spacer (L 116).

Part. S0565



for round tubes Dia. 18 - 20 mm

Expansion plugs

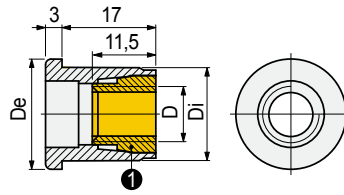

Tube dimensions ① Expansion cone

Outside mm	Thickness mm	Inside mm	Thread D	De mm	Di mm	Code
Ø 20	1,5	17	M8	20	17	698681

- Material: plug in polyamide PA (black), expansion cone in brass.
- Standard packaging: expansion cone is supplied separated from the plug.
- Weight: 0,01Kg.
- Packaging: 100 pieces.
- Max recommended tightening torque: 1 Kgm.

• Assembly Part. S0565

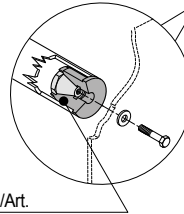
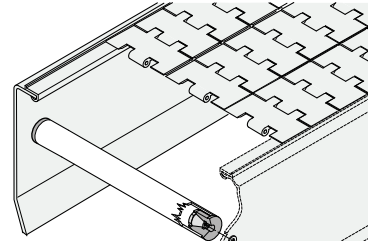

Part./Art.
Réf. S0565

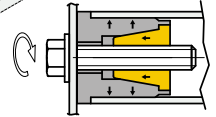

Tightening the bolt, the plug expands and stays firmly in the tube.

• Application example of Part. S0565 for return chain rollers

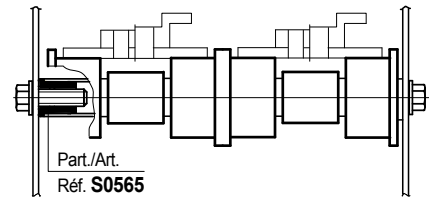

Part./Art.
Réf. S0565

• Application example of Part. S0565 for serpentine return

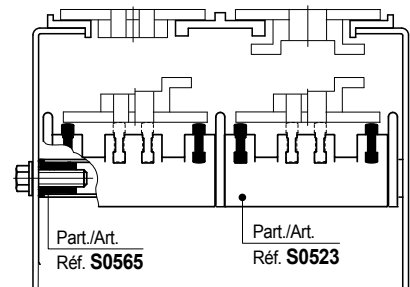

Part./Art.
Réf. S0565

Part./Art.
Réf. S0523

- **Material:** Polyethylene UHMWPE with molecular density 5.600.000 g/mol.
Characteristics: new material Polyethylene ULF brown red (UHMWPE): reduced friction coefficient, higher wear resistance.
- **Linear expansion coefficient:** $2 \times 10^{-4} \text{ } ^\circ\text{C}^{-1}$
Calculation of thermal expansion see Technical information.
- **Operating temperature ULF - brown red:**
In air (- 40 to + 45 °C).
In hot water (+ 45 °C).
- **Polyethylene ULF is FDA approved**
Polyethylene ULF complies with the Code of Federal Regulations Title 21, § 177.1520 "Olefin Polymers" of the Food and Drug Administration (FDA) of April 1, 2008.

• **Use Part. S0771 - S0776**
Overhead transport of PET bottles.

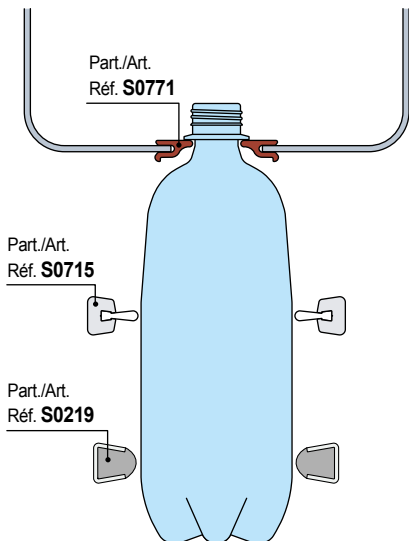

• **Accessories:** see Guide - Rail Clamps

Part./Art./Réf.
S0216 - S0903

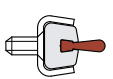

Part./Art./Réf.
S0275

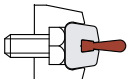

Part./Art./Réf.
S0215

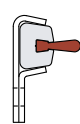

Part./Art./Réf.
S0211 - S0446

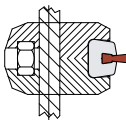

Part./Art./Réf.
S0210 - S0210P

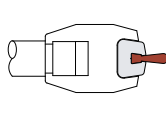

Part./Art./Réf.
S0217

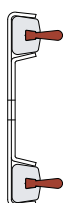

Part./Art./Réf.
S0213

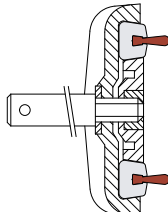

Neck transport guides

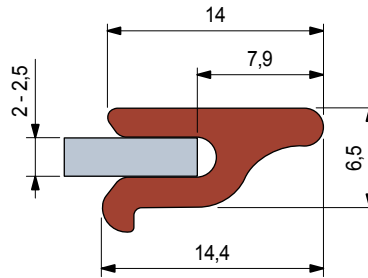

Material	Packaging metres	Code
UHMWPE		
ULF - brown red	40	UL626363N

- Standard packaging: coil.

Guide rail

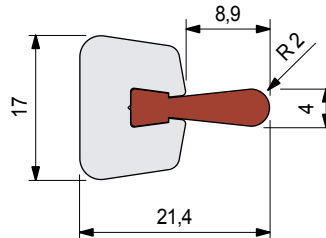

Length metres	Code	Weight kg/m
3	UL691892N	0,59

- Material: metal profile in anodized aluminium.
Plastic profile in Polyethylene ULF (brown red).
- Standard packaging: The plastic and metal profiles are supplied disassembled.
- Min. curvature radius: 500 mm.
- Packaging: 60 metres.

Part. S0771

Part. S0715



- **Material:** Polyethylene UHMWPE with molecular density 5.600.000 g/mol.
Characteristics: new material Polyethylene ULF brown red (UHMWPE): reduced friction coefficient, higher wear resistance.
- **Linear expansion coefficient:** $2 \times 10^{-4} \text{ } ^\circ\text{C}^{-1}$
Calculation of thermal expansion see Technical information.
- **Operating temperature ULF - brown red:**
In air (- 40 to + 45 °C).
In hot water (+ 45 °C).
- **Polyethylene ULF is FDA approved**
Polyethylene ULF complies with the Code of Federal Regulations Title 21, § 177.1520 "Olefin Polymers" of the Food and Drug Administration (FDA) of April 1, 2008.

- **Use Part. S0594 - S0654 - S0835**
Overhead transport of PET bottles.

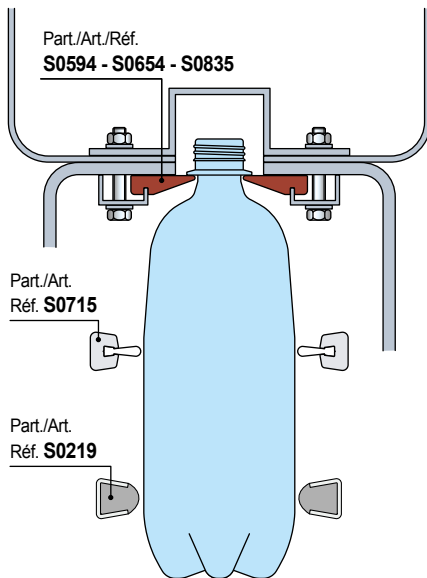

Neck transport guides

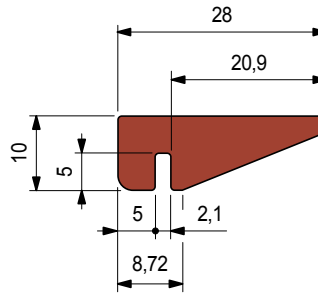

Material	Length metres	Code
UHMWPE		
ULF - brown red	3	UL691702N

- Min. curvature radius: 750 mm.
- Packaging: 45 metres (in 3 m length 10Ft).

Part. S0594



Neck transport guides

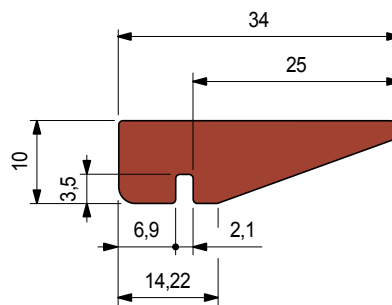

Material	Length metres	Code
UHMWPE		
ULF - brown red	3	UL691722N

- Min. curvature radius: 750 mm.
- Packaging: 24 metres.

Part. S0654



Part. **S0308**



■ Neck transport guide

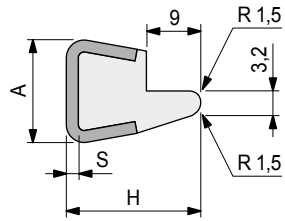

S	H	A
mm	mm	mm
1,5	22,5	16
2	23	17

Thickness S mm	Metal profile material	Length metres	Code	Weight kg/m
Plastic profile in polyethylene UHMWPE (white)				
1,5	Austenitic stainless steel	3	65602	0,65

- Min. curvature radius: 160 mm.
- Linear expansion coefficient: $4 \times 10^{-5} \text{ } ^\circ\text{C}^{-1}$.
- Calculation of thermal expansion see Technical information.
- Packaging: 24 metres (in 3 m length 10Ft).
- Accessories:



Guide - Rail
Clamps.

- **Material:** Polyethylene UHMWPE with molecular density 5.600.000 g/mol.
- **Characteristics:** new material Polyethylene ULF brown red (UHMWPE): reduced friction coefficient, higher wear resistance.
- **Operating temperature White, Green, Black:**
In air (- 40 to + 80 °C).
In hot water (+ 70 °C).

- **Use of Part. S0308**
Overhead trasport of PET bottles.

Part./Art.
Réf. **S0308**

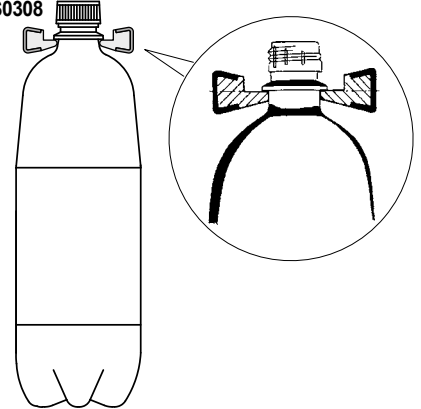

- **Deflection of Part. S0308 - S0393 - S0596**

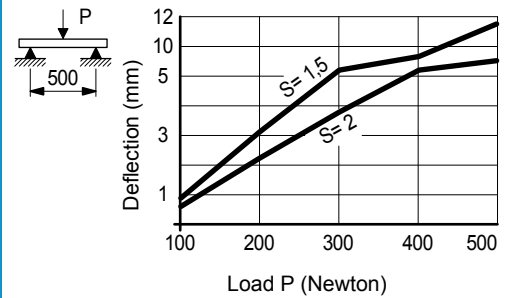

Part. S0393

- **Material:** Polyethylene UHMWPE with molecular density 5.600.000 g/mol.
Characteristics: new material Polyethylene ULF brown red (UHMWPE): reduced friction coefficient, higher wear resistance.
- **Operating temperature White, Green, Black:**
In air (- 40 to + 80 °C).
In hot water (+ 70 °C).

Label protection guide

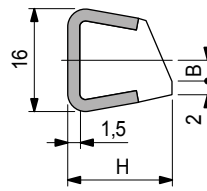

H	B
mm	mm
15	3,9
17	3,6

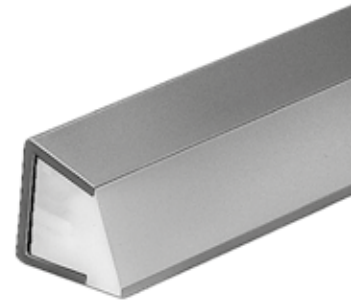

Metal profile material	Length metres	H mm	Code	Weight kg/m
Austenitic stainless steel	3	15	62522	0,50

• Use of Part. S0393

Transport of PET bottles with petaloid bottom.
The guide can be used to stabilize, and protect label from damage.

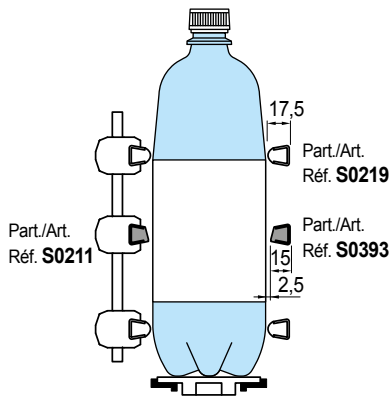

Transport of glass bottles.

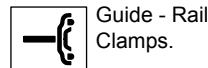
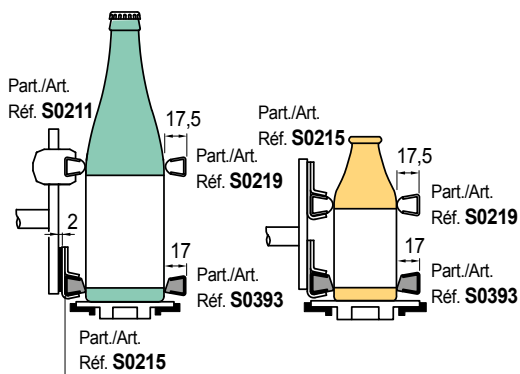

Guide - Rail
Clamps.

- Plastic profile material: polyethylene UHMWPE (white).
- Min. curvature radius: 145 mm.
- Linear expansion coefficient: $4 \times 10^{-5} \text{ } ^\circ\text{C}^{-1}$.
- Calculation of thermal expansion see Technical information.
- Packaging: 24 metres.
- Accessories:

Part. **S0317**



■ Guide rail (half round)

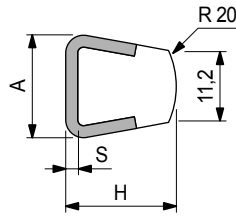

S	H	A
mm	mm	mm
1,5	17,5	16
2	18	17

Thickness S	Metal profile material	Length metres	Code	Weight kg/m
-------------	------------------------	---------------	------	-------------

Plastic profile in polyethylene UHMWPE (white)

1,5	Austenitic stainless steel	3	69072	0,54
		6	69302	

- Min. curvature radius: 145 mm.
- Linear expansion coefficient: $4 \times 10^{-5} \text{ } ^\circ\text{C}^{-1}$.
- Calculation of thermal expansion see Technical information.
- Packaging: 24 metres (in 3 m length 10Ft).
48 metres (in 6 m length).
- Accessories:

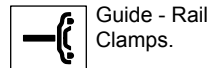

Part. **S0223**



■ Neck transport guide

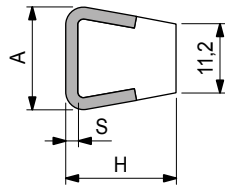

S	H	A
mm	mm	mm
1,5	17,5	16
2	18	17

Thickness S	Metal profile material	Length metres	Code	Weight kg/m
-------------	------------------------	---------------	------	-------------

1,5	Austenitic stainless steel	3	61031	0,54
	Zinc plated steel	3	63971	

- Colour: white.
- Antistatic polyethylene UHMWPE (black) available upon request with minimum quantities.
- Min. curvature radius: 145 mm.
- Linear expansion coefficient: $4 \times 10^{-5} \text{ } ^\circ\text{C}^{-1}$.
- Calculation of thermal expansion see Technical information.
- Packaging: 24 metres (in 3 m length 10Ft).
- Accessories:

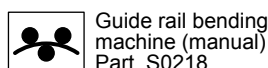
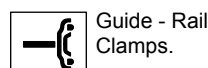

- **Material:** Polyethylene UHMWPE with molecular density 5.600.000 g/mol.
Characteristics: new material Polyethylene ULF brown red (UHMWPE): reduced friction coefficient, higher wear resistance.
- **Operating temperature White, Green, Black:**
In air (- 40 to + 80 °C).
In hot water (+ 70 °C).

- **Use of Part. S0317**
Delicate containers
(ex: empty cans, empty PET).

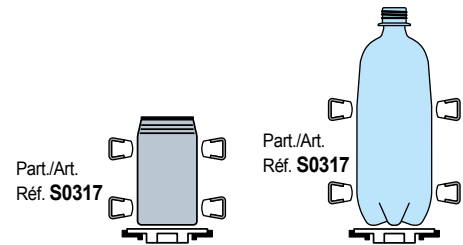

- **Deflection of Part. S0317 - S0223**

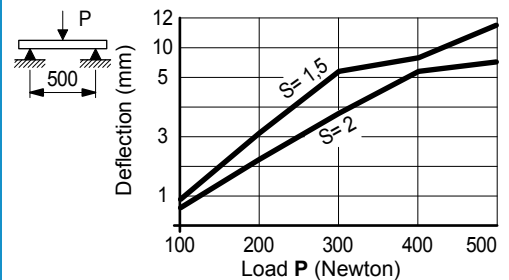

- **Use of Part. S0223**
Middle delicate containers
(ex: full PET).

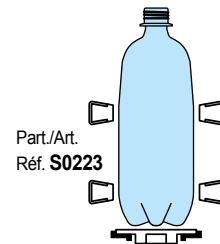

- **Assembly of Part. S0317 - S0223**

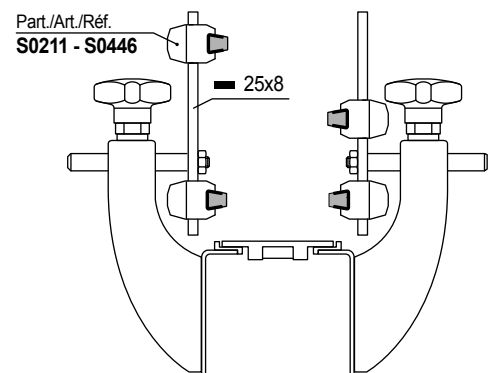

- **Material:** Polyethylene UHMWPE with molecular density 5.600.000 g/mol.
Characteristics: new material Polyethylene ULF brown red (UHMWPE): reduced friction coefficient, higher wear resistance.
- **Operating temperature White, Green, Black:**
In air (- 40 to + 80 °C).
In hot water (+ 70 °C).

- **Use of S0219 - S0247**
Medium strength containers (ex: latten, glass).

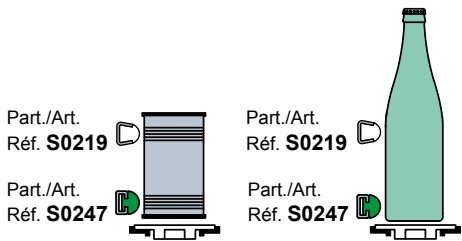

Plastic profile of Part. S0247 can be disassembled.

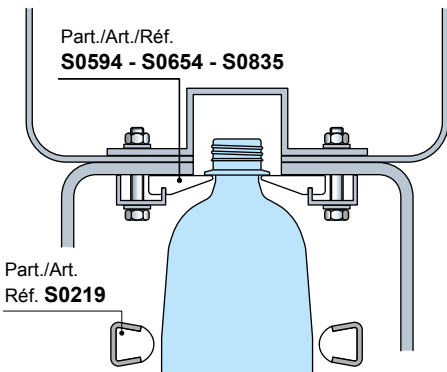

- **Deflection of Part. S0219**

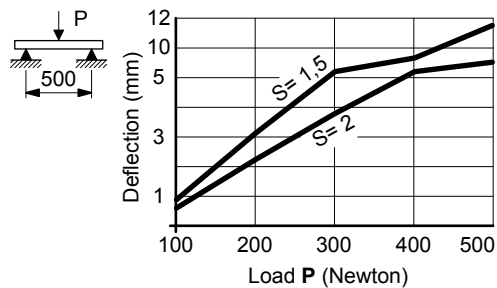

- **Deflection of Part. S0247**

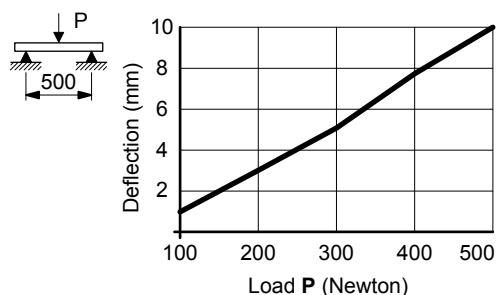

Guide rail (round)

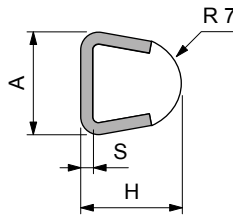

S	H	A
mm	mm	mm
1,5	17,5	16
2	18	17

Thickness S mm	Metal profile material	Length metres	Code	Weight kg/m
----------------	------------------------	---------------	------	-------------

Plastic profile in polyethylene UHMWPE (white)				
1,5	Austenitic stainless steel	3	60161	0,54
	Zinc plated steel	6	69292	
2	Austenitic stainless steel	3	61753	0,54
	Zinc plated steel	6	67113	

Plastic profile in polyethylene ULF (brown red)				
2	Austenitic stainless steel		UL634543N	0,54

- Min. curvature radius: 145 mm.
- Linear expansion coefficient: $4 \times 10^{-5} \text{ } ^\circ\text{C}^{-1}$.
Calculation of thermal expansion see Technical information.
- Packaging: 12 metres (in 3 m length 10Ft).
18 metres (in 6 m length).
- Accessories:

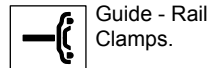

Guide rail (round)

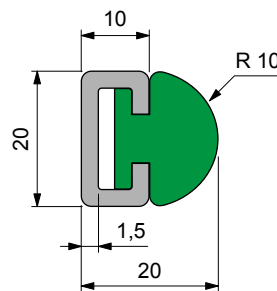

Length metres	Metal profile material	Code	Weight kg/m
---------------	------------------------	------	-------------

Plastic profile material in polyethylene UHMWPE (green)			
3	Austenitic stainless steel	63911	0,67
	Zinc plated steel	63921	

- Min. curvature radius: 145 mm.
- Linear expansion coefficient: $2 \times 10^{-4} \text{ } ^\circ\text{C}^{-1}$.
Calculation of thermal expansion see Technical information.
- Accessories:

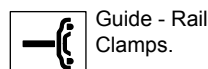

Part. S0219



Part. S0247



Part. **S0346**



In aluminium

■ Guide rail (half round)

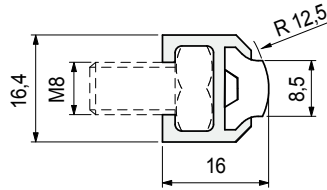

Length metres	Code	Weight kg/m
3	60204	0,24
6	60214	

- Colour: white.
- Metal profile in anodized aluminium.
- Min. curvature radius: 110 mm.
- Linear expansion coefficient: $2 \times 10^{-4} \text{ } ^\circ\text{C}^{-1}$.
- Calculation of thermal expansion see Technical information.
- Packaging: 18 metres (in 3 m length 10Ft).
96 metres (in 6 m length).
- Accessories:



Guide rail bending machine (manual)
Part. S0218.

- **Material:** Polyethylene UHMWPE with molecular density 5.600.000 g/mol.
Characteristics: new material Polyethylene ULF brown red (UHMWPE): reduced friction coefficient, higher wear resistance.
- **Operating temperature White, Green, Black:**
In air (- 40 to + 80 °C).
In hot water (+ 70 °C).

- **Use of Part. S0346**
Conveyors with limited lateral loads (ex brick).

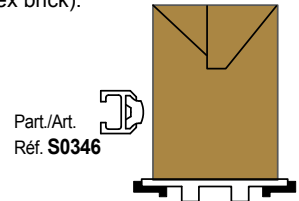

- **Assembly of Part. S0346**

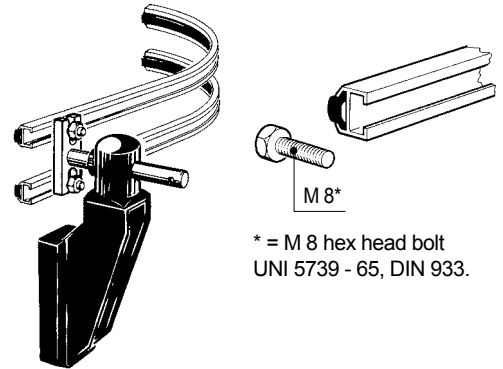

* = M 8 hex head bolt
UNI 5739 - 65, DIN 933.

- **Deflection of Part. S0346**

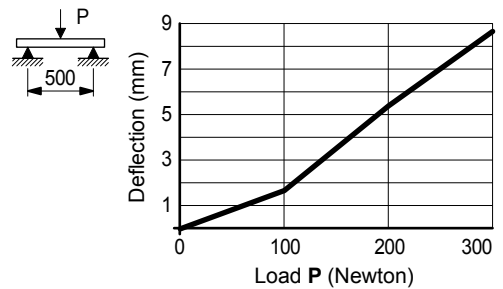

- **Assembly of Part. S0369**
Insert the guides and tighten the set screws.

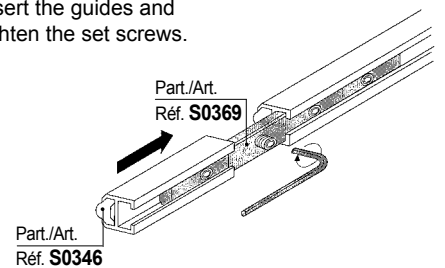

- **Material:** Polyethylene UHMWPE with molecular density 5.600.000 g/mol.
Characteristics: new material Polyethylene ULF brown red (UHMWPE): reduced friction coefficient, higher wear resistance.
- **Operating temperature White, Green, Black:**
In air (- 40 to + 80 °C).
In hot water (+ 70 °C).

- **Use of Part. S0770 - S0769** Medium strength containers. (ex. latten, glass)

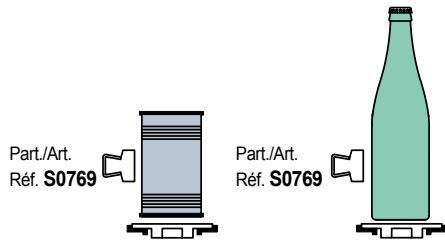

■ Guide rail (flat)

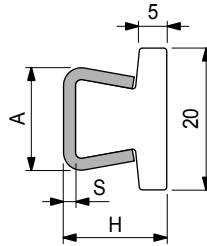

S mm	H mm	A mm
1,5	17	16
2	17,5	17



Part. S0770

Thickness

S mm	Metal profile material	Length metres	Code	Weight kg/m
2	Austenitic stainless steel	3	609213N	0,71

- Colour: white.
- Antistatic polyethylene UHMWPE (black) available upon request with minimum quantities.
- Min. curvature radius: 160 mm.
- Linear expansion coefficient: $4 \times 10^{-5} \text{ } ^\circ\text{C}^{-1}$.
- Calculation of thermal expansion see Technical information.
- Packaging: 24 metres.
- Accessories:



Guide - Rail
Clamps.

Part. **S0768**



■ Guide rail (flat)

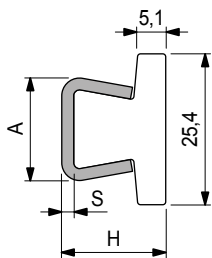

S	H	A
mm	mm	mm
1,5	17	16
2	17,5	17

Thickness	Metal	Length	Code	Weight
S	profile	metres		kg/m
mm	material			
1,5	Austenitic stainless steel	3	609083N	0,63
2	Austenitic stainless steel	3	609113N	0,74

- Colour: white.
- Antistatic polyethylene UHMWPE (black) available upon request with minimum quantities.
- Min. curvature radius: 160 mm.
- Linear expansion coefficient: $4 \times 10^{-5} \text{ } ^\circ\text{C}^{-1}$.
- Calculation of thermal expansion see Technical information.
- Packaging: 24 metres.
- Accessories:

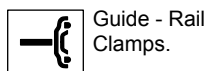

Part. **S0767**



■ Guide rail (flat)

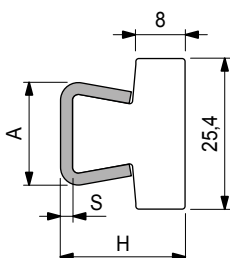

S	H	A
mm	mm	mm
1,5	20,5	16
2	21	17

Thickness	Metal	Length	Code	Weight
S	profile	metres		kg/m
mm	material			
2	Austenitic stainless steel	3	609063N	0,82

- Colour: white.
- Min. curvature radius: 160 mm.
- Linear expansion coefficient: $4 \times 10^{-5} \text{ } ^\circ\text{C}^{-1}$.
- Calculation of thermal expansion see Technical information.
- Packaging: 24 metres.
- Accessories:

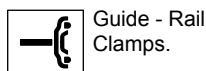

- **Material:** Polyethylene UHMWPE with molecular density 5.600.000 g/mol.
Characteristics: new material Polyethylene ULF brown red (UHMWPE): reduced friction coefficient, higher wear resistance.

• **Operating temperature White, Green, Black:**

- In air (- 40 to + 80 °C).
- In hot water (+ 70 °C).

- **Use of Part. S0770 - S0769** Medium strength containers (ex. latten, glass)

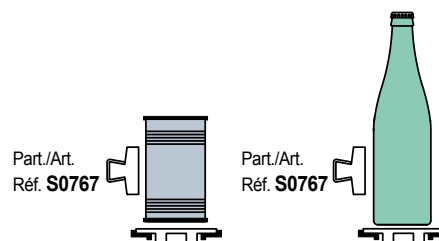

- **Material:** Polyethylene UHMWPE with molecular density 5.600.000 g/mol.
Characteristics: new material Polyethylene ULF brown red (UHMWPE): reduced friction coefficient, higher wear resistance.
- **Operating temperature White, Green, Black:**
In air (- 40 to + 80 °C).
In hot water (+ 70 °C).

- **Use of Part. S0273**
Rugged containers with delicate surface (ex. decorated glass bottles).

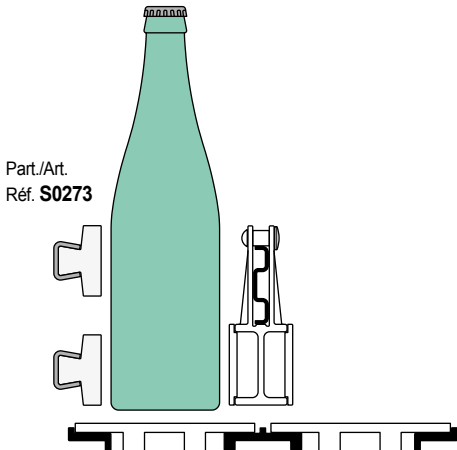

Part./Art.
Réf. **S0273**

- **Deflection of Part. S0273**

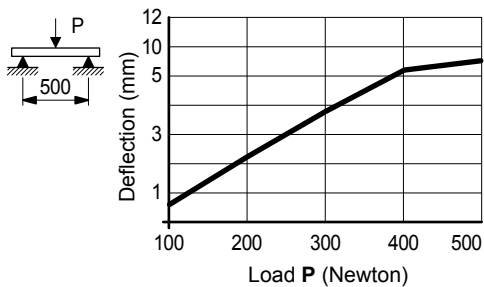

- **Use of Part. S0765**
Rugged containers with delicate surface (ex. decorated glass bottles).

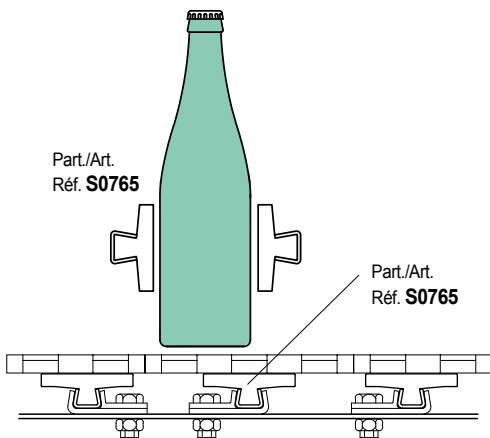

Part./Art.
Réf. **S0765**

Part./Art.
Réf. **S0765**

■ Guide rail (extra-flat)

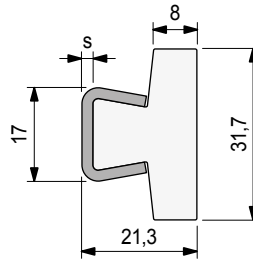

Thickness S mm	Metal profile material	Length metres	Code	Weight kg/m
Plastic profile in polyethylene UHMWPE (white)				
2	Austenitic stainless steel	3	66791	0,76
		6	67602	

- Antistatic polyethylene UHMWPE (black) available upon request with minimum quantities.
- Min. curvature radius: 160 mm.
- Linear expansion coefficient: $4 \times 10^{-5} \text{ } ^\circ\text{C}^{-1}$.
- Calculation of thermal expansion see Technical information.
- Packaging: 12 metres (in 3 m length 10Ft).
18 metres (in 6 m length).
- Accessories:

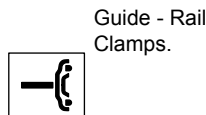

■ Guide rail (extra-flat)

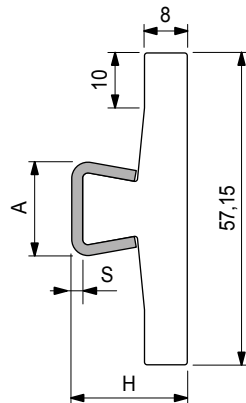

S mm	H mm	A mm
1,5	20,5	16
2	21	17

Thickness S mm	Metal profile material	Length metres	Code	Weight kg/m
1,5	Austenitic stainless steel	3	608943N	0,95
2	Austenitic stainless steel	6	608983N	1,06

- Colour: white.
- Min. curvature radius: 200 mm.
- Linear expansion coefficient: $4 \times 10^{-5} \text{ } ^\circ\text{C}^{-1}$.
- Calculation of thermal expansion see Technical information.
- Packaging: 24 metres.
- Accessories:

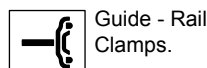

Part. S0273



Part. S0765



Part. **S0422**



■ Guide rail (extra flat)

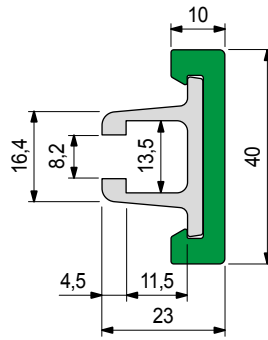

Metal profile material	Length metres	Code	Weight kg/m
Anodized aluminium	3	65248M	0,70
	6	65258M	

- Use: rugged containers.
- Material: plastic profile in polyethylene UHMWPE (green).
- State of supply: the plastic and metal profiles are supplied assembled.
- Plastic Profile spare part. (green): S088568309 (6 metres).
- Plastic Profile spare part. (ULF): S0885648423 (6 metres).
- Metal Profile in Anodized aluminium spare part: S0884608662 (3 metres).
- Min. curvature radius: 280 mm.
- Packaging: 24 metres.

- **Material:** Polyethylene UHMWPE with molecular density 5.600.000 g/mol.
Characteristics: new material Polyethylene ULF brown red (UHMWPE): reduced friction coefficient, higher wear resistance.
- **Linear expansion coefficient:** $2 \times 10^{-4} \text{ } ^\circ\text{C}^{-1}$
Calculation of thermal expansion see Technical information.
- **Operating temperature Green Black:**
In air (- 40 to + 80 °C).
In hot water (+ 70 °C).

• Deflection

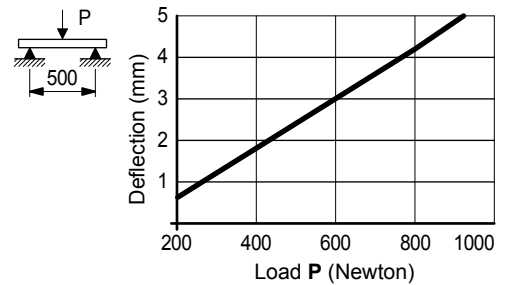

• Fixing of Part. S0422

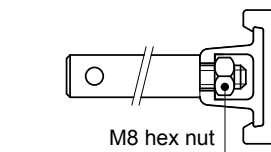
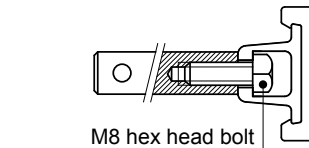

Part. **S0369**



■ Connecting bar

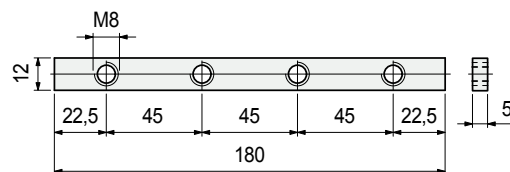

Material	Code	Weight kg/m
Zinc plated steel	69995	0,10

- Packaging: 8 pieces.

• Assembly of Part. S0369

Insert the guides and tighten the set screws.

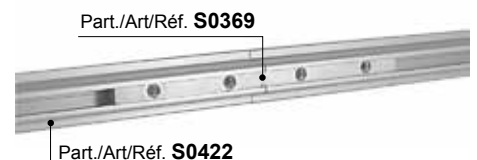
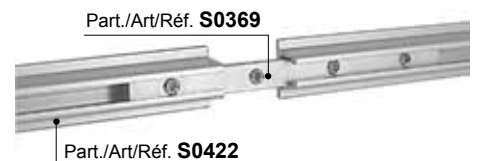

Part. **S0642**

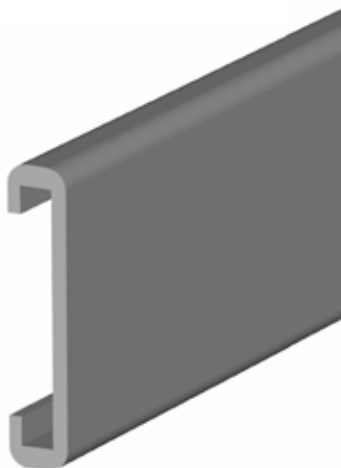

■ Guide rail (extra flat)

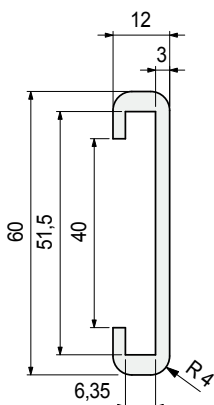

Material	Length metres	Code
UHMWPE		
Black	3	652292

- Linear expansion coefficient: $2 \times 10^{-4} \text{ } ^\circ\text{C}^{-1}$. Calculation of thermal expansion see Technical information.
- Packaging: 3 metres.
- Accessories:



Metal profile
Part. S0643.

Part. **S0643**



■ Metal profile

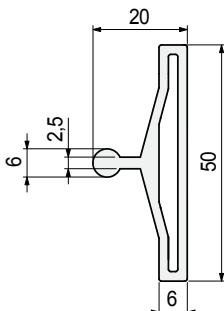

Metal profile material	Length metres	Code
Anodized aluminium	3	652302

- Can be used in combination with Part. S0642.
- Packaging: 3 metres.
- Accessories:



Guide - Rail
Clamps.

• Use of Part. S0642 - S0643

Rugged containers with delicate surface (for example decorated glass bottles).

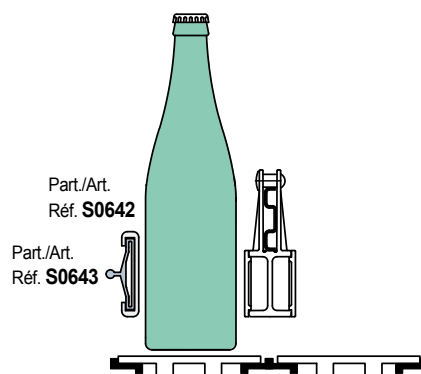

Part. S0645



- **Use of Part. S0645**
Protection of round steel rods

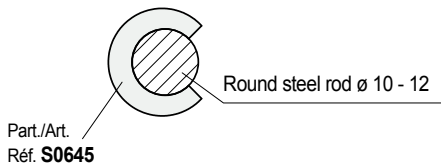

- **Fixing of Part. S0539**
Assembly / disassembly

- Fixing with plate.

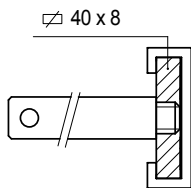

- Fixing with metal profile Part. S0537.

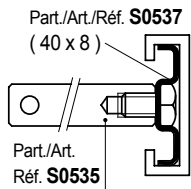

Profile for round steel rods

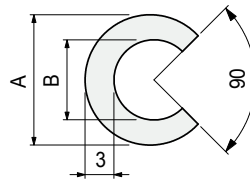

Material	Use	A mm	B mm	Code
UHMWPE				
White	for rod ø 12	17	11	652352

- Linear expansion coefficient: $2 \times 10^{-4} \text{ } ^\circ\text{C}^{-1}$.
- Standard packaging: coil.
- Packaging: 50 metres.

Guide rail (extra flat)

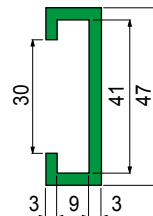

Material	Length metres	Code	Weight kg/m
Black	6	689321	0,23
Green	3	689291	

Part. S0539



- Material: Polyethylene PE 500.000.
- Linear expansion coefficient: $2,5 \times 10^{-4} \text{ } ^\circ\text{C}^{-1}$.
- Calculation of thermal expansion see Technical information.
- Packaging: 24 metres (in 3 m length).
48 metres (in 6 m length).
- Accessories:

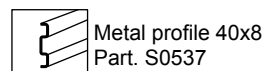

Part. **S0191**

Part. **S0296**



■ Guide rail (extra-large)

Part. S0191

Part. S0296

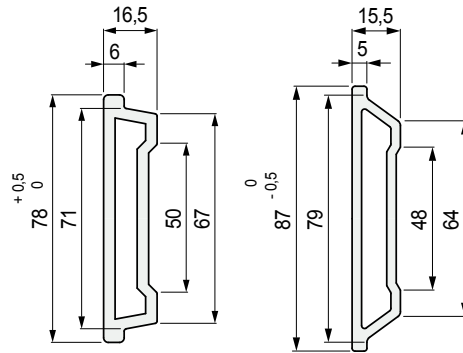

Material	Length metres	Code	Weight kg/m
Black	3	S019157131	0,60
	3	S029668811	

- Material: polyethylene PE 500.000.
- Min. curvature radius: 200 mm.
- Linear expansion coefficient: $2,5 \times 10^{-4} \text{ } ^\circ\text{C}^{-1}$.
Calculation of thermal expansion see Technical information.
- Packaging: 15 metres (in 3 m length).
- Accessories:

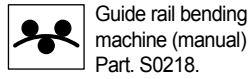

• Use of Part. S0191 - S0296

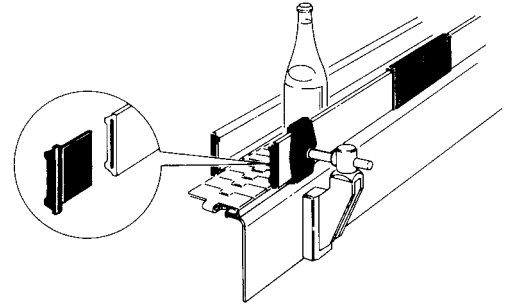

- The guide rails must be used with a 60 x 6 plate

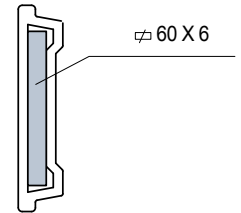

• Deflection of Part. S0191 - S0296

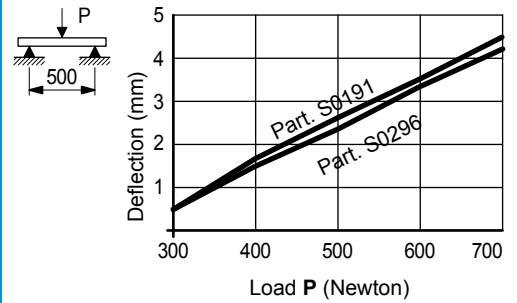

• Assembly of Part. S0376 - S0377

- Press-fit.
- Seal with silicon.

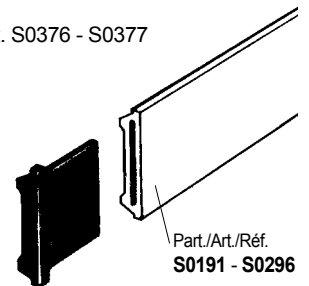

- Leave a gap between the plug and the plate to allow for contraction at low temperatures.

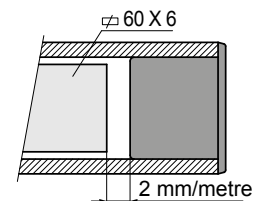

Part. **S0378**



Joint clamp

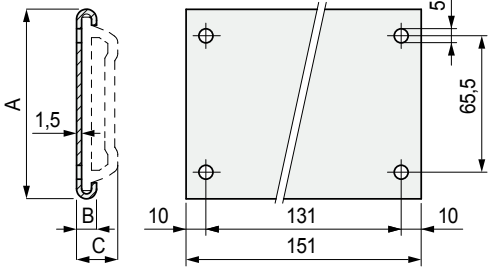

• **Assembly of Part. S0378**
 Assembly with self-tapping screws
 4,8 x 9,5 DIN 7970

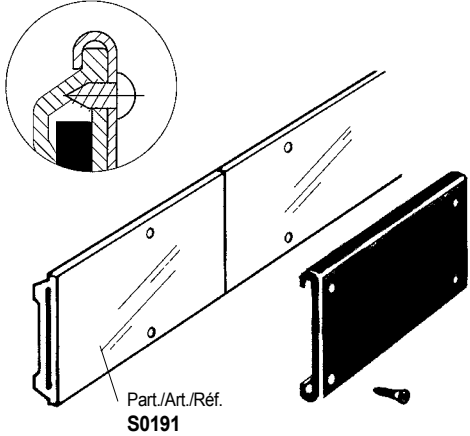

Use	A mm	B mm	C mm	Code
Applicable to Part. S0191	81,5	9	18	S037863646

- Material: clamp and fixing screws in austenitic stainless steel.
- Standard packaging: 24 pieces complete with fixing screws.

Part. **S0581**

■ Roller side guide

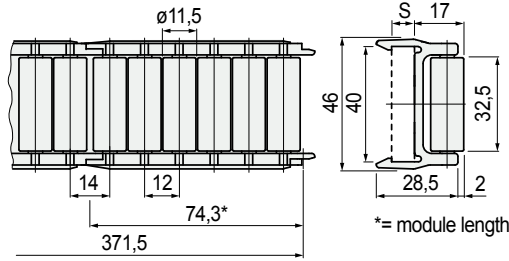

Sideflexing

Version	S mm	Code	Weight kg/m
For 40x8 plate	6	603322	0,62

- Material: frame in acetal POM (black), rollers in Polyethylene PE (white).
- Standard packaging: strands of 0,371 metres (5 modules).
- Packaging: 4,5 metres (12 strands).
- Accessories:

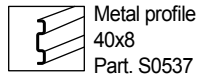

• Use of Part. S0581- S0585

For thin walled and delicate containers (like aluminium cans, PET bottles, decorated card-board).

• Fixing of Part. S0581

Snap-on assembly / disassembly

- Fixing with plate.

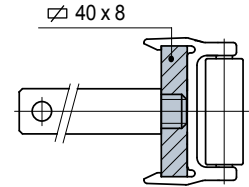

- Fixing with metal profile Part. S0537.

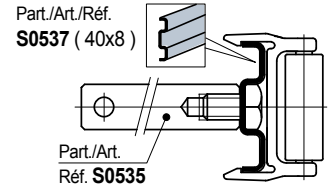

• Min. curvature radius Part. S0581

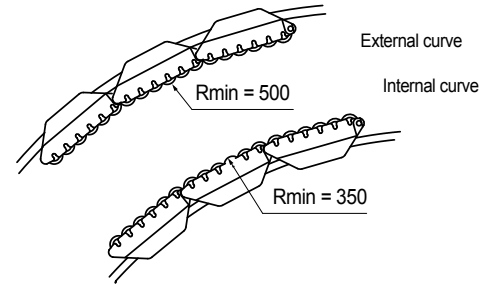

S0581

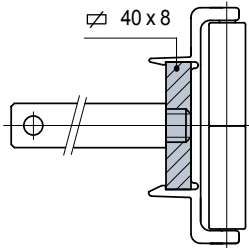
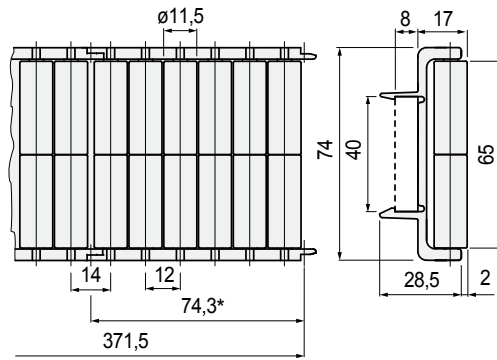

Part./Art./Réf.
S0537 (40x8)

Part./Art.
Réf. **S0535**

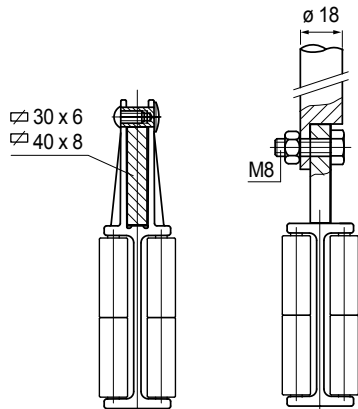
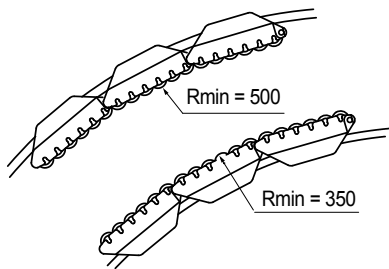
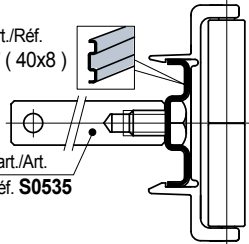

Part./Art./Réf.
S0537 (40x8)

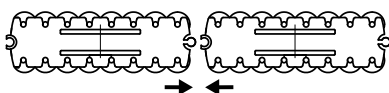
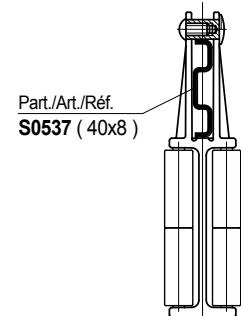

Version	Code	Weight kg
For 40x8 plate	603312	1,01

- Material: frame in acetal POM (black), rollers in Polyethylene PE (white).
- Standard packaging: strands of 0,371 metres (5 modules).
- Packaging: 4,5 metres (12 strands).
- Accessories:

 Metal profile
40x8
Part. S0537

Part. **S0580**

■ Roller side guide



Sideflexing

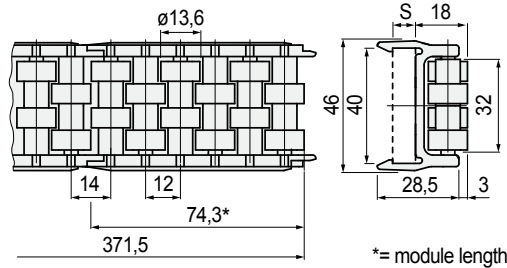

*= module length

Version	S mm	Code	Weight kg/m
For 40x8 plate	8	603302	0,61
For 40x10 plate	10	611772	

- Material: frame in Acetal POM (black), rollers in Acetal POM (white).
- Standard packaging: strands of 0,371 metres (5 modules).
- Packaging: 4,5 metres (12 strands).
- Accessories:

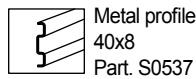

Part. **S0557**

■ Centre roller guide



Sideflexing

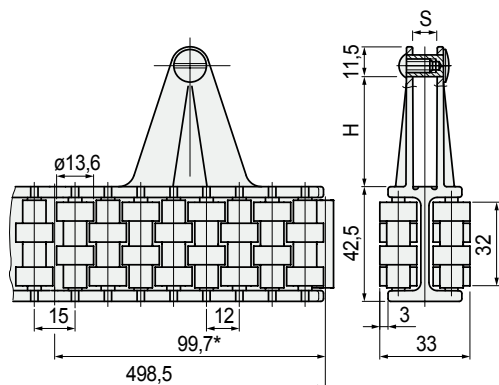

*= module length

Version	H mm	S mm	Code	Weight kg/m
For 30x6 plate	40	8	695991N	1,22

- Can be used in combination with Part. S0580.
- Material: frame in Acetal POM (black), rollers in Acetal POM (white).
- Min. curvature radius: 335 mm.
- Standard packaging: strands of 0,498 metres (5 modules).
- Packaging: 4,5 metres (9 strands).
- Accessories:



• Fixing of Part. S0580

Snap-on assembly / disassembly

- Fixing with plate.

- ▧ 40 x 8
- ▧ 40 x 10

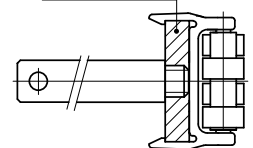

- Fixing with metal profile Part. S0537.

Part./Art./Réf.
S0537 (40x8)

Part./Art.
Réf. **S0535**

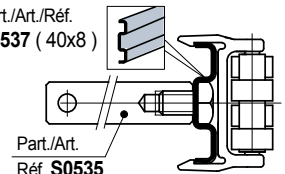

• Min. curvature radius Part. S0580

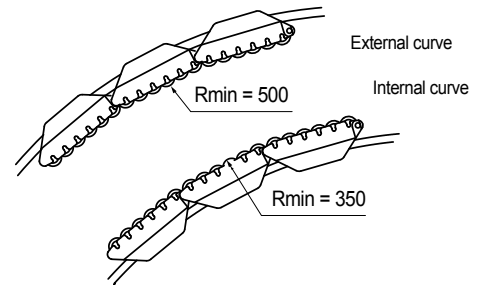

• Fixing of Part. S0557

Assembly / disassembly.

- Fixing with plate.

- ▧ 30 x 6
- ▧ 40 x 8

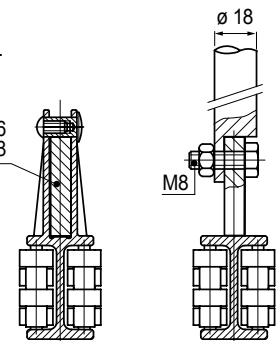

- Fixing with metal profile Part. S0537.

Part./Art./Réf.
S0537 (40x8)

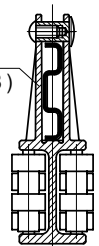

• Modular system Part. S0580 - S0557

The guide consists of modules with snap-on assembly.

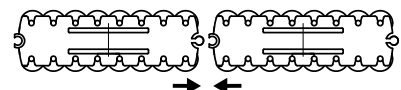

- **Assembly of Part. S0570**
Guide position (Part. S0557) to allow assembly with divider module.

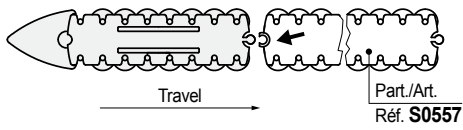

■ Divider module

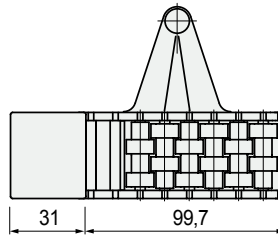

Version	Code	Weight kg
For 40x8 plate	601162N	0,15

- Material: frame in Acetal POM (black), rollers in Acetal POM (white). Separation block in polyethylene PE (black).
- Packaging: 2 pieces.

Part. S0570



- **Use of Part. S0580 - S0557**
For medium strength containers (tin cans, glass strong aluminium cans).

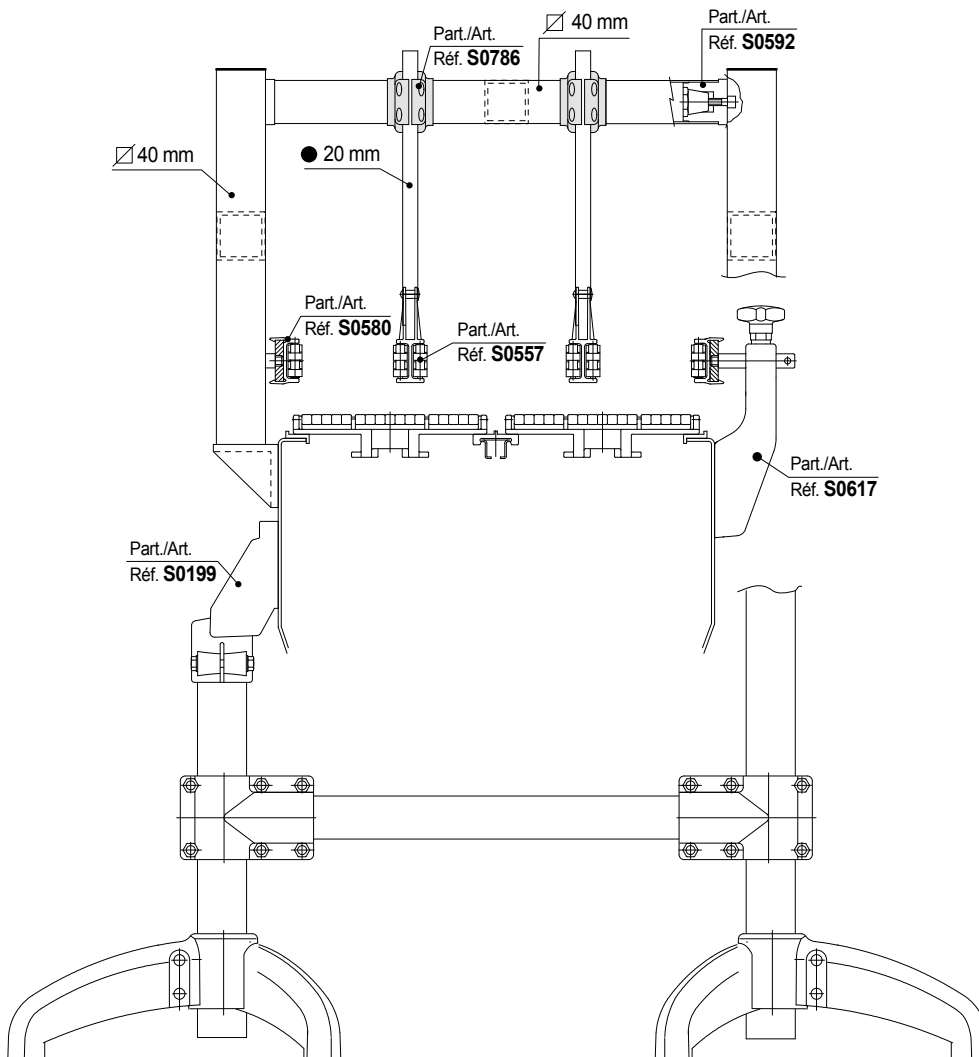

Part. S0580

Roller side guide

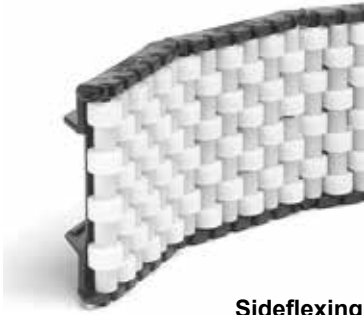

Sideflexing

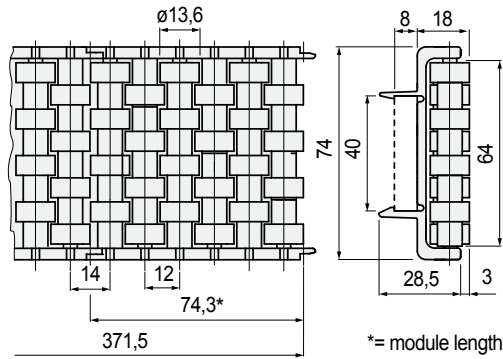

Version	Code	Weight kg
For 40x8 plate	603292	0,99

- Material: frame in Acetal POM (black), rollers in Acetal POM (white).
- Standard packaging: strands of 0,371 metres (5 modules).
- Packaging: 4,5 metres (12 strands).
- Accessories:

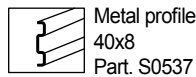

• **Use of Part. S0580 - S0557**
For medium strength containers (tin cans, glass, strong aluminium cans).

• **Fixing of Part. S0580**
Snap-on assembly / disassembly

- Fixing with plate.

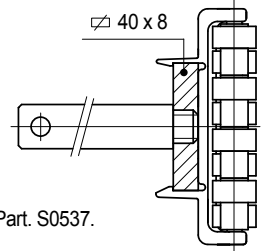

- Fixing with metal profile Part. S0537.

Part./Art./Réf. S0537 (40x8)

Part./Art. Réf. S0535

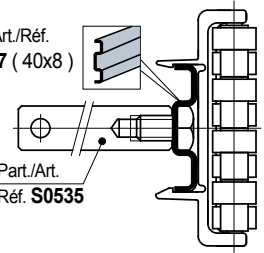

• **Min. curvature radius Part. S0580**

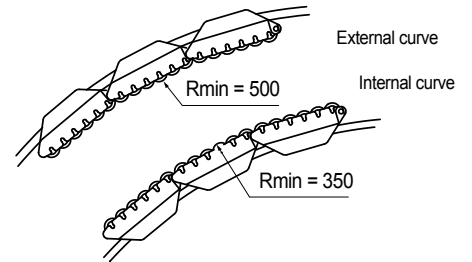

- Fixing with plate.

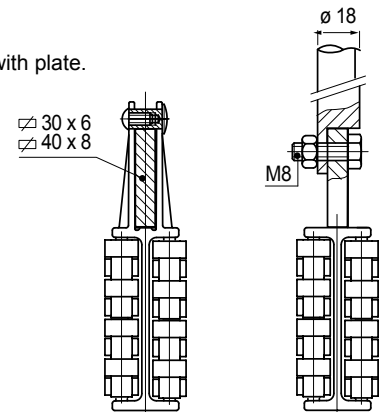

- Fixing with metal profile Part. S0537.

Part./Art./Réf. S0537(40x8)

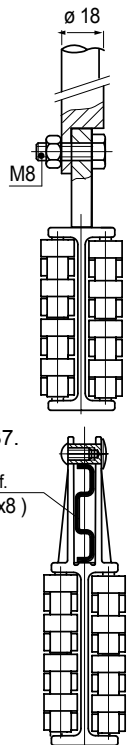

• **Fixing of Part. S0557**
Assembly / disassembly.

• **Modular system Part. S0580 - S0557**
The guide consists of modules with snap-on assembly.

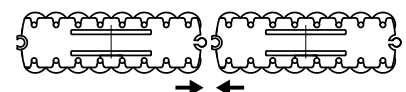

• Types of guides using our 40x8 metal profile.

Part. S0539

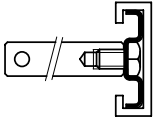

Part. S0580

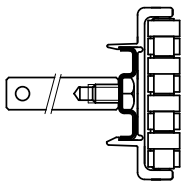

Part. S0557

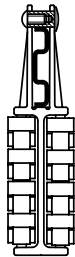

Part. S0581

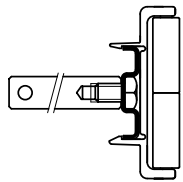

• Deflection of Part. S0537

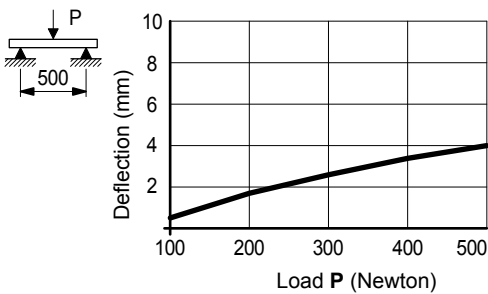

■ Metal profile 40x8

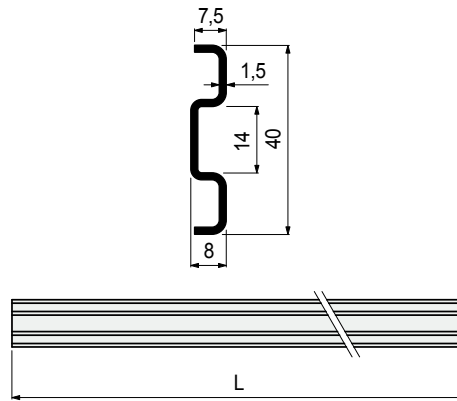

Material	Length L mm	Code
Austenitic stainless steel	3209	689231

- Min. curvature radius: 500 mm.
- Weight: 0,72 Kg/m.
- Packaging: 19,25 metres (in 3209 mm length),
- Accessories:

Part. S0537



■ Bolts set

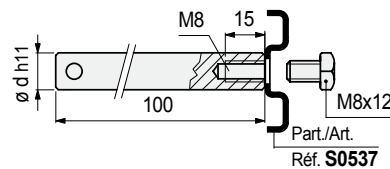

pin dia. d mm	Code	Weight kg/m
12	684641	0,12

- Material: austenitic stainless steel.
- State of supply: complete with screw M8 x 12.
- Packaging: 24 pieces.

Part. S0535



Part. **S0757**

■ Roller side guides with cylinder rollers

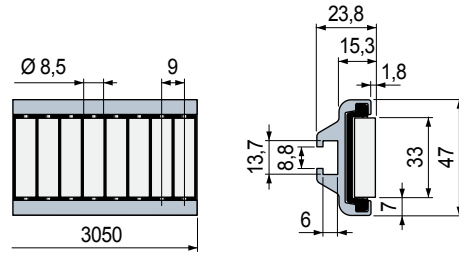

Cylinder rollers material	Code	Weight kg
Polyethylene PE (white)	645083	1,20

- Material: metal profile in anodized aluminium, rollers module in acetal POM (black), roller pins in stainless steel.
- Standard packaging: strands 3,05 metres.
- Packaging: 2 strands.

Cylinder roller module

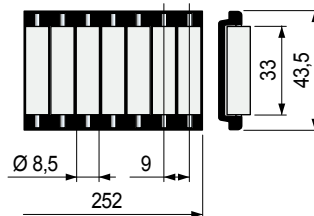

Code	Cylinder rollers material	Code
607933	Polyethylene PE	644613
607943	(white)	

- **Characteristics** Part. S0757
 - Self supporting structure.
 - Anodized aluminium profile.
 - Quick and easy installation by standard bolts.
 - Can be used straight running and sideflexing.

• **Assembly** Part. S0757

M8 hex head bolt

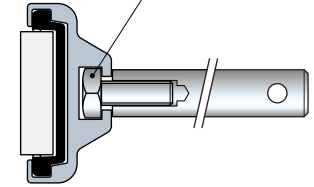

• **Accessories**

Part. S0369 - Connecting bar

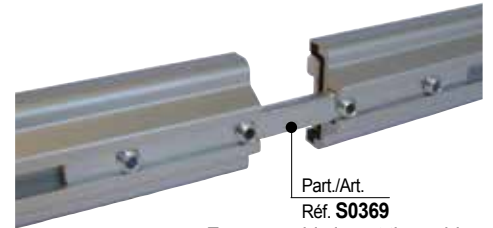

For assembly insert the guides and tighten the set screw.

• **Min. curvature radius** Part. S0757

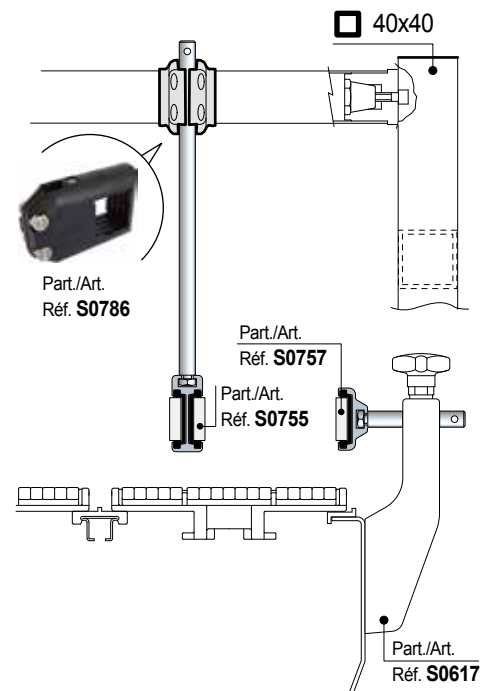
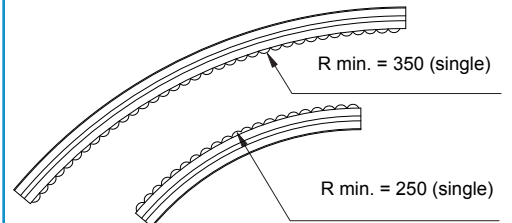

- **Characteristics** Part. S0755
 - Self supporting structure.
 - Anodized aluminium profile.
 - Quick and easy installation by standard bolts.
 - Can be used straight running and sideflexing.

- **Assembly** Part. S0755

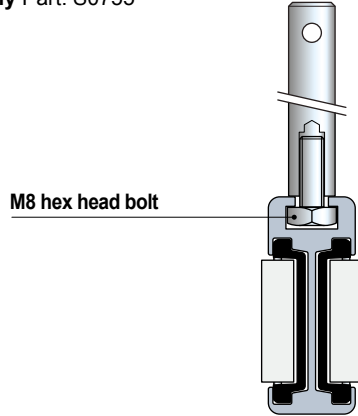

- **Accessories**

Part. S0369 - Connecting bar



- **Min. curvature radius** Part. S0755

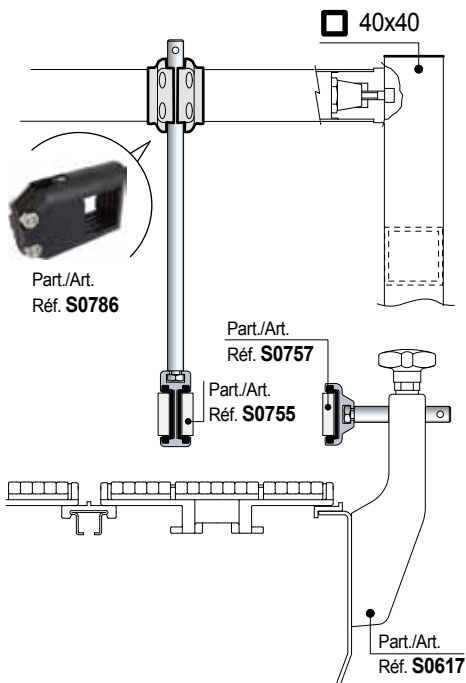
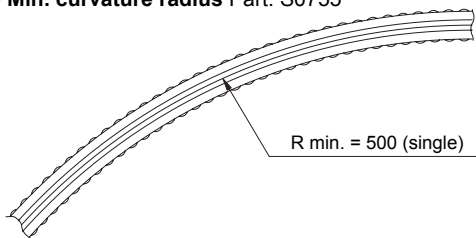

Centre guide with cylinder rollers

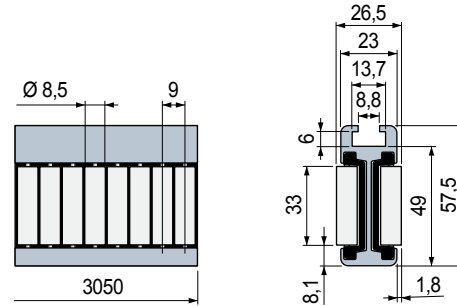

Cylinder rollers material	Code	Weight kg
Polyethylene PE (white)	645103	1,75

- Material: metal profile in anodized aluminium, rollers module in acetal POM (black), roller pins in stainless steel.
- Standard packaging: strands 3,05 metres.
- Packaging: 2 strands.

Part. S0755



Cylinder roller module

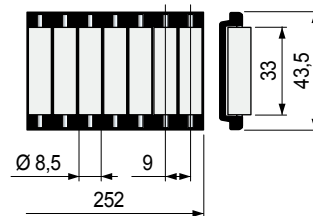

Cylinder rollers material	Code
Polyethylene PE (white)	644613

• Characteristics Part. S0755

- Self supporting structure.
- Anodized aluminium profile.
- Quick and easy installation by standard bolts.
- Can be used straight running and sideliflexing.

• Assembly Part. S0755

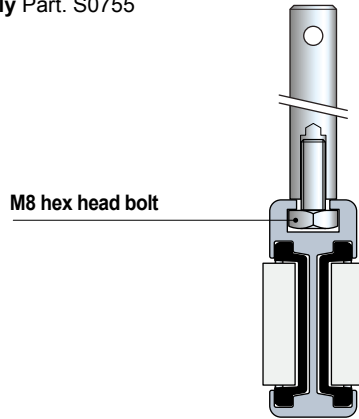

• Accessories

Part. S0369 - Connecting bar



• Min. curvature radius Part. S0755

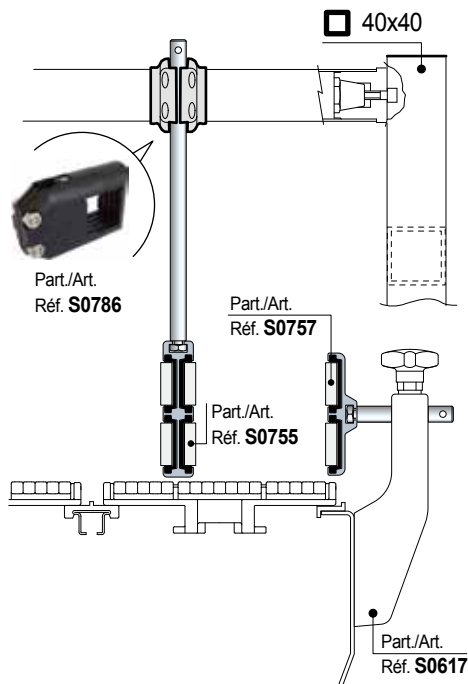
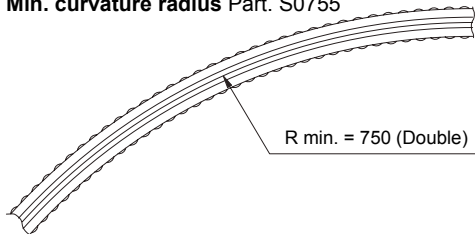

■ Centre guide with cylinder rollers

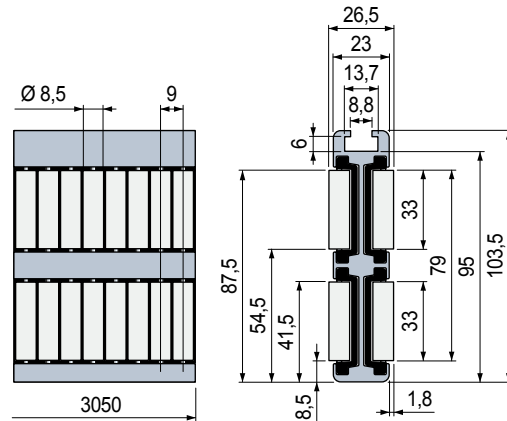

Cylinder rollers material	Code	Weight kg
Polyethylene PE (white)	645113	3,00

- Material: metal profile in anodized aluminium, rollers module in acetal POM (black), roller pins in stainless steel.
- Standard packaging: strands 3,05 metres.
- Packaging: 2 strands.

Part. S0755

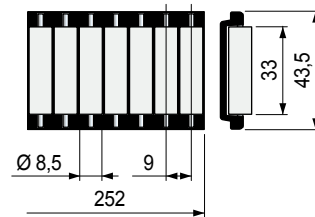

Cylinder rollers material	Code
Polyethylene PE (white)	644613

Part. **S0868**

■ Roller side guides with cylinder rollers

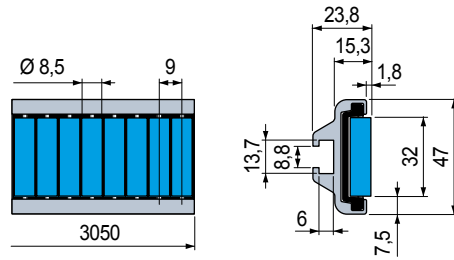

Cylinder rollers material	Code	Weight kg
SEBS rubber (Blue)	647573	1,20

- Material: metal profile in anodized aluminium, rollers module in acetal POM (black), roller pins in stainless steel.
- Standard packaging: strands 3,05 metres.
- Packaging: 2 strands.

- **Characteristics** Part. S0868
 - Self supporting structure.
 - Anodized aluminium profile.
 - Quick and easy installation by standard bolts.
 - Can be used straight running and sideflexing.

• **Assembly** Part. S0868

M8 hex head bolt

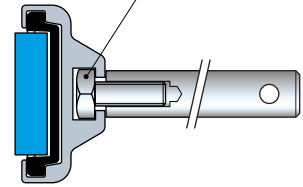

• **Accessories**

Part. S0369 - Connecting bar

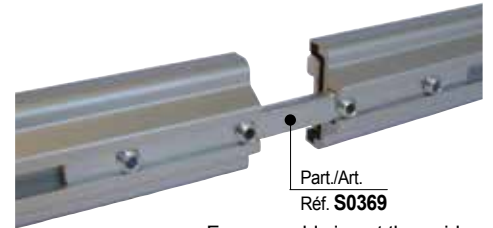

For assembly insert the guides and tighten the set screw.

• **Min. curvature radius** Part. S0868

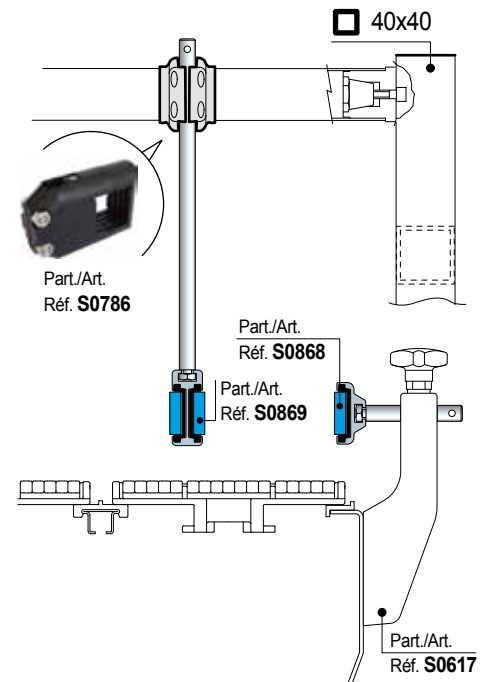
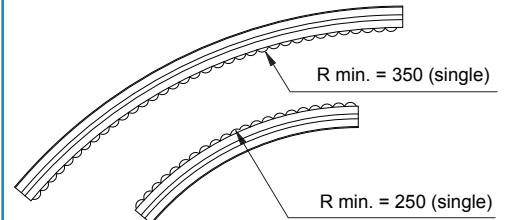

- **Characteristics** Part. S0869
 - Self supporting structure.
 - Anodized aluminium profile.
 - Quick and easy installation by standard bolts.
 - Can be used straight running and sideliflexing.

- **Assembly** Part. S0869

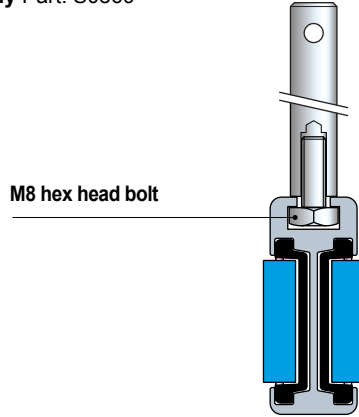

- **Accessories**

Part. S0369 - Connecting bar

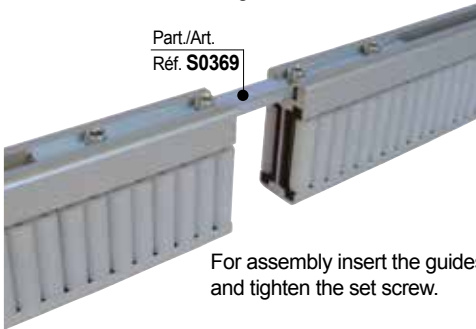

- **Min. curvature radius** Part. S0869

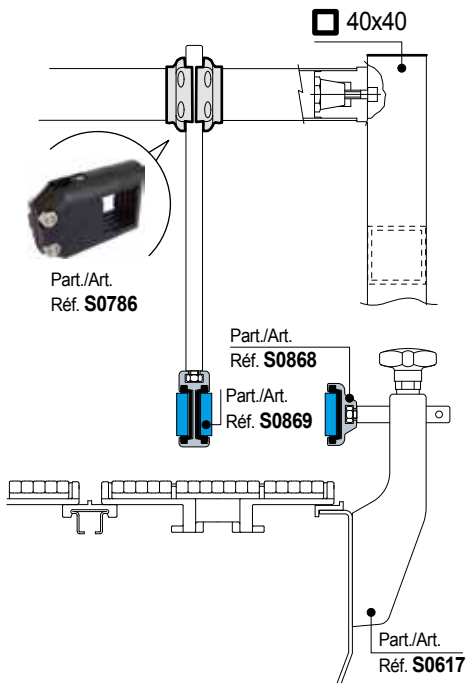
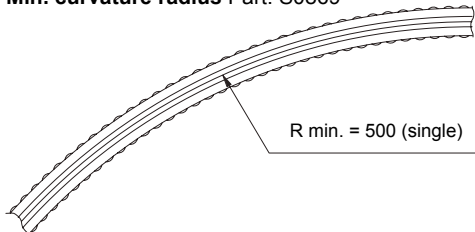

- **Centre guide with cylinder rollers**

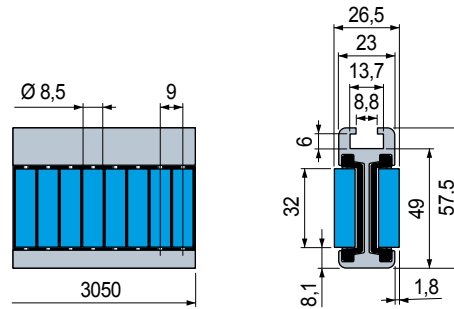

Cylinder rollers material	Code	Weight kg
SEBS rubber (Blue)	647583	1,75

- Material: metal profile in anodized aluminium, rollers module in acetal POM (black), roller pins in stainless steel.
- Standard packaging: strands 3,05 metres.
- Packaging: 2 strands.

Part. S0869



Part. **S0868**

■ Roller side guides with cylinder rollers

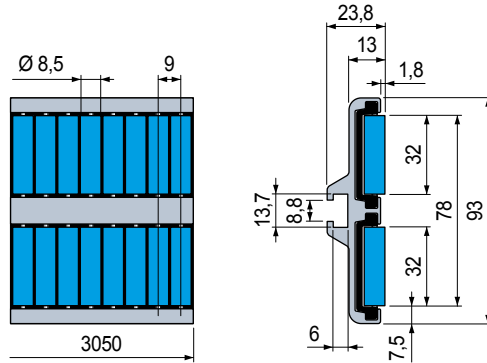

Cylinder rollers material	Code	Weight kg
SEBS rubber (blue)	647593	2,00

- Material: metal profile in anodized aluminium, rollers module in acetal POM (black), roller pins in stainless steel.
- Standard packaging: strands 3,05 metres.
- Packaging: 2 strands.

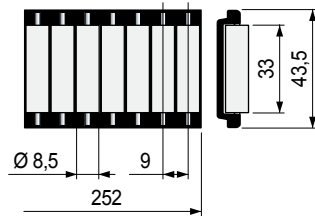

Cylinder rollers material	Code
Polyethylene PE (white)	644623

- **Characteristics** Part. S0868
 - Self supporting structure.
 - Anodized aluminium profile.
 - Quick and easy installation by standard bolts.
 - Can be used straight running and sideflexing.

• **Assembly** Part. S0868

M8 hex head bolt

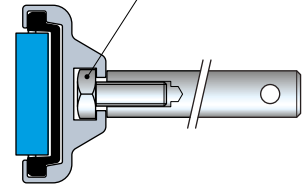

• **Accessories**

Part. S0369 - Connecting bar

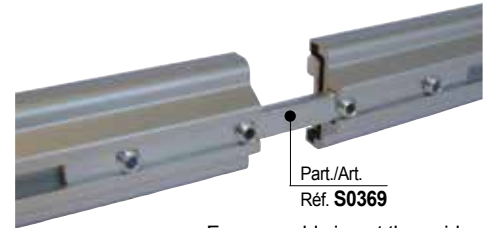

For assembly insert the guides and tighten the set screw.

• **Min. curvature radius** Part. S0868

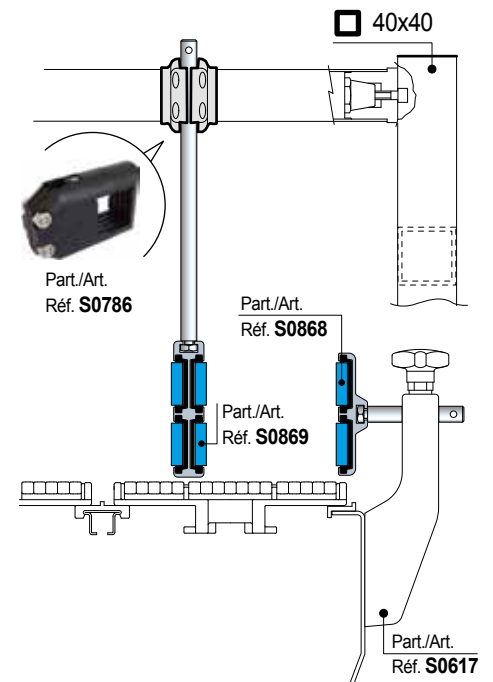
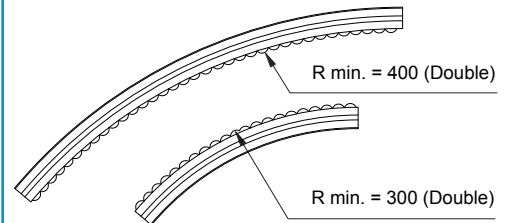

- **Characteristics** Part. S0869
 - Self supporting structure.
 - Anodized aluminium profile.
 - Quick and easy installation by standard bolts.
 - Can be used straight running and sideliflexing.

• **Assembly** Part. S0869

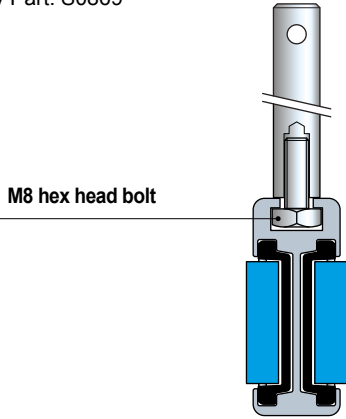

• **Accessories**

Part. S0369 - Connecting bar

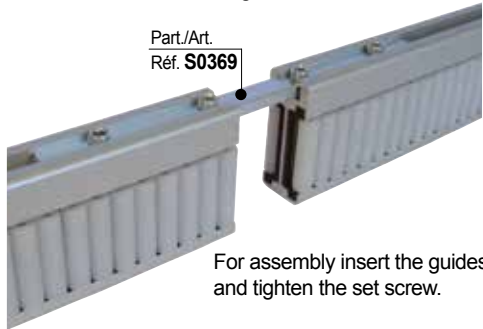

• **Min. curvature radius** Part. S0869

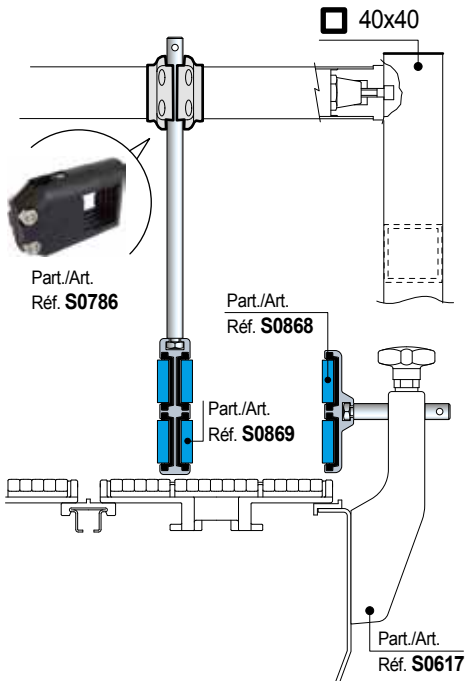
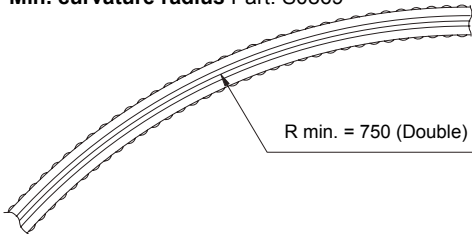

■ **Centre guide with cylinder rollers**

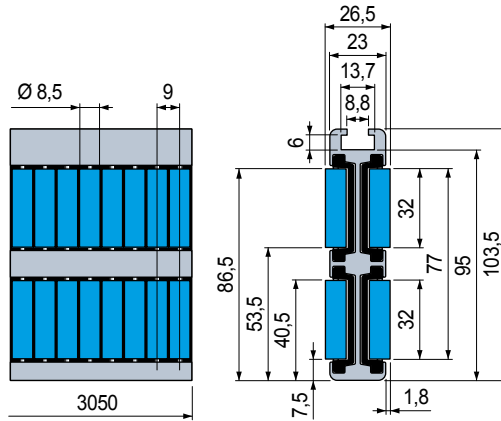

Cylinder rollers material	Code	Weight kg
SEBS rubber (blue)	647603	3,00

- Material: metal profile in anodized aluminium, rollers module in acetal POM (black), roller pins in stainless steel.
- Standard packaging: strands 3,05 metres.
- Packaging: 2 strands.

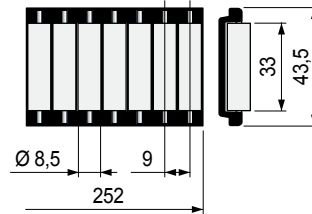

Cylinder rollers material	Code
Polyethylene PE (white)	644623

Part. S0869



Part. **S0756**

■ Pearl roller side guide

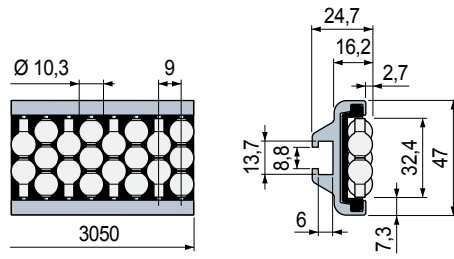

Pearl material	Code	Weight kg
Polyethylene PE (Aubergine)	645123	1,15
Polyethylene PE (white)	645133	

- Material: metal profile in anodized aluminium, rollers module in acetal POM (black), roller pins in stainless steel.
- Standard packaging: strands 3,05 metres.
- Packaging: 2 strands.

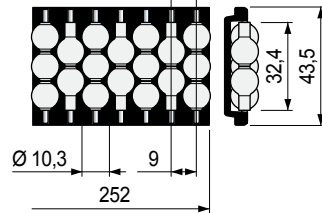

Pearl material	Code
Polyethylene PE (Aubergine)	644653
Polyethylene PE (white)	644633

- **Characteristics** Part. S0756
 - Self supporting structure.
 - Anodized aluminium profile.
 - Quick and easy installation by standard bolts.
 - Can be used straight running and sideflexing.

• **Assembly** Part. S0756

M8 hex head bolt

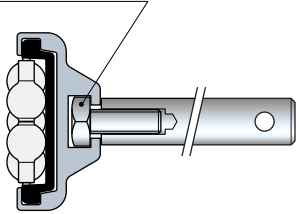

• **Accessories**

Part. S0369 - Connecting bar

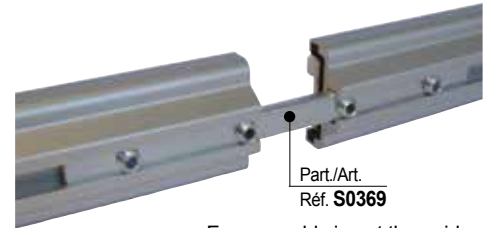

For assembly insert the guides and tighten the set screw.

• **Min. curvature radius** Part. S0756

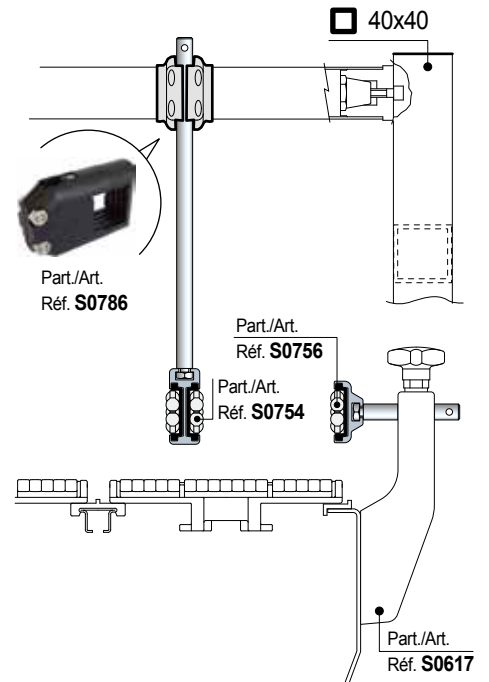
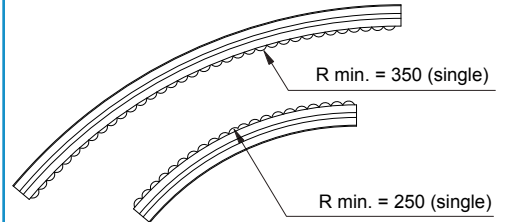

• Characteristics Part. S0754

- Self supporting structure.
- Anodized aluminium profile.
- Quick and easy installation by standard bolts.
- Can be used straight running and sideliflexing.

• Assembly Part. S0754

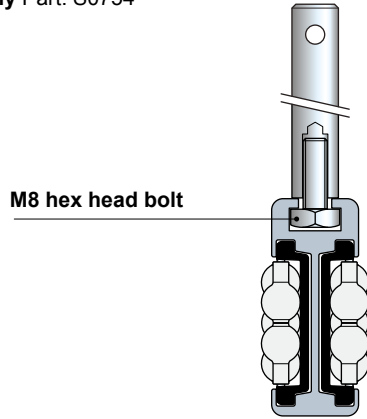

• Accessories

Part. S0369 - Connecting bar

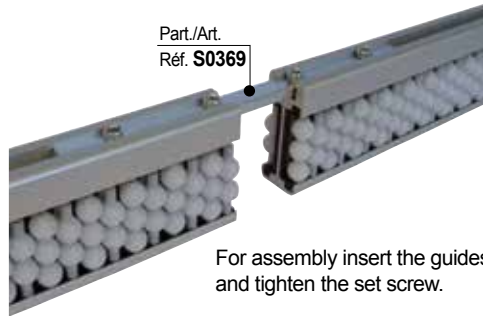

• Min. curvature radius Part. S0754

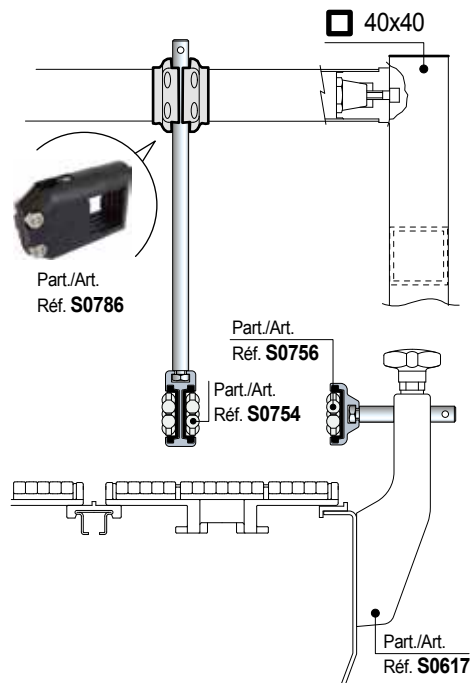
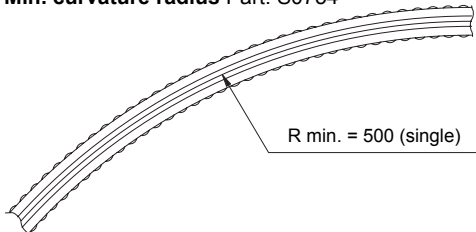

■ Pearls roller centre guide

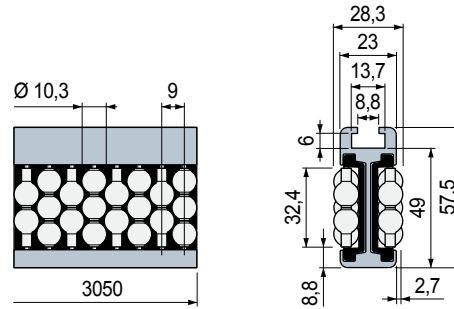

Part. S0754



Pearl material	Code	Weight kg
Polyethylene PE (white)	645173	1,70

- Material: metal profile in anodized aluminium, rollers module in acetal POM (black), roller pins in stainless steel.
- Standard packaging: strands 3,05 metres.
- Packaging: 2 strands.

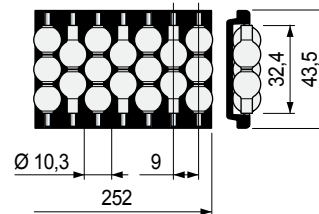

Pearl material	Code
Polyethylene PE (Aubergine)	644653
Polyethylene PE (white)	644633

Part. **S0756**

■ Pearl roller side guide

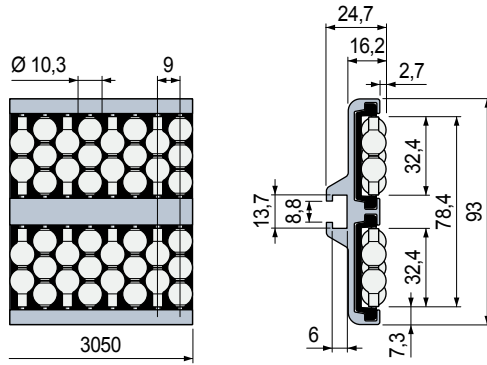

Pearl material	Code	Weight kg
Polyethylene PE (Aubergine)	645143	1,95
Polyethylene PE (white)	645153	

- Material: metal profile in anodized aluminium, rollers module in acetal POM (black), roller pins in stainless steel.
- Standard packaging: strands 3,05 metres.
- Packaging: 2 strands.

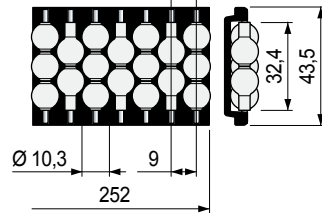

Pearl material	Code
Polyethylene PE (Aubergine)	644653
Polyethylene PE (white)	644633

- **Characteristics** Part. S0756
 - Self supporting structure.
 - Anodized aluminium profile.
 - Quick and easy installation by standard bolts.
 - Can be used straight running and sideflexing.

• **Assembly** Part. S0756

M8 hex head bolt

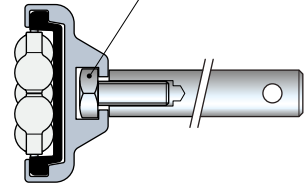

• **Accessories**

Part. S0369 - Connecting bar

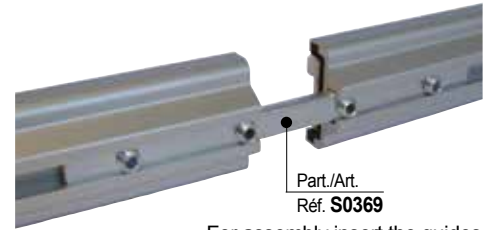

For assembly insert the guides and tighten the set screw.

• **Min. curvature radius** Part. S0756

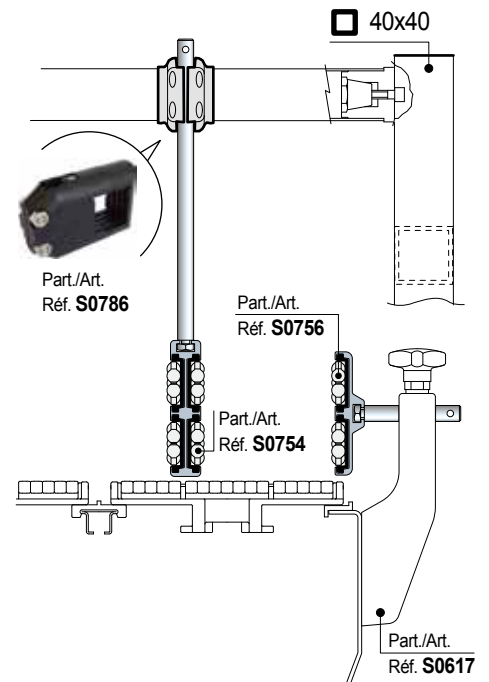
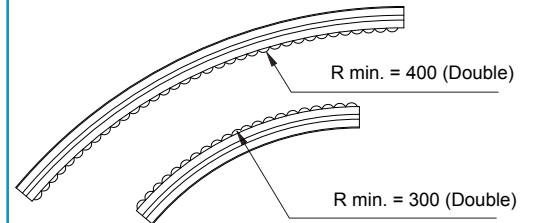

Part. S0856

■ **Roller side guides**

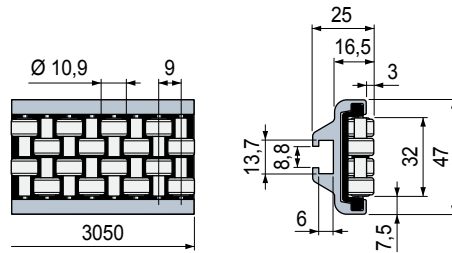
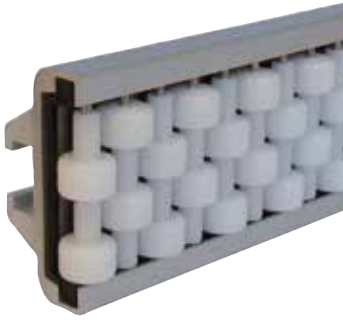

Rollers material	Code	Weight kg
Acetal POM (white)	645203	1,20

- Material: metal profile in anodized aluminium, rollers module in acetal POM (black), roller pins in stainless steel.
- Standard packaging: strands 3,05 metres.
- Packaging: 2 strands.

- **Characteristics Part. S0856**
 - Self supporting structure.
 - Anodized aluminium profile.
 - Quick and easy installation by standard bolts.
 - Can be used straight running and sideliflexing.

• **Assembly Part. S0856**

M8 hex head bolt

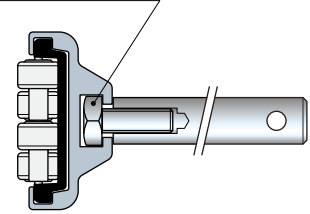

• **Accessories**

Part. S0369 - Connecting bar

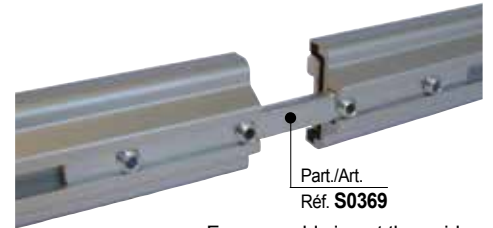

For assembly insert the guides and tighten the set screw.

• **Min. curvature radius Part. S0856**

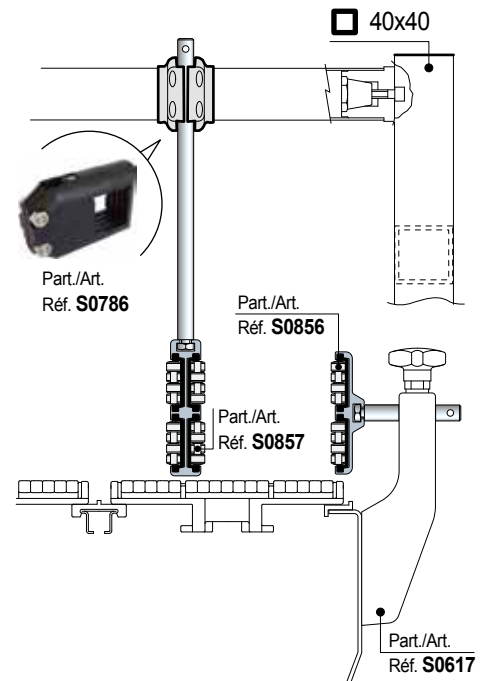
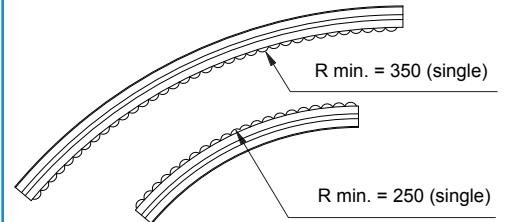

- **Characteristics** Part. S0857
 - Self supporting structure.
 - Anodized aluminium profile.
 - Quick and easy installation by standard bolts.
 - Can be used straight running and sideflexing.

- **Assembly** Part. S0857

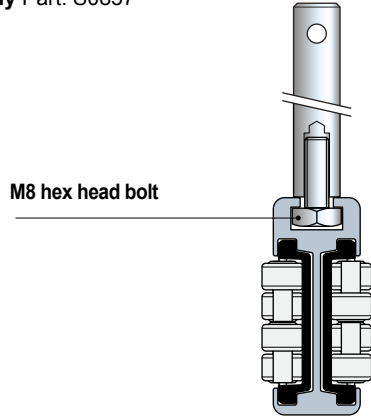

- **Accessories**

Part. S0369 - Connecting bar

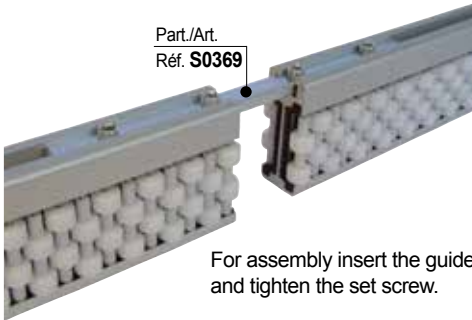

- **Min. curvature radius** Part. S0857

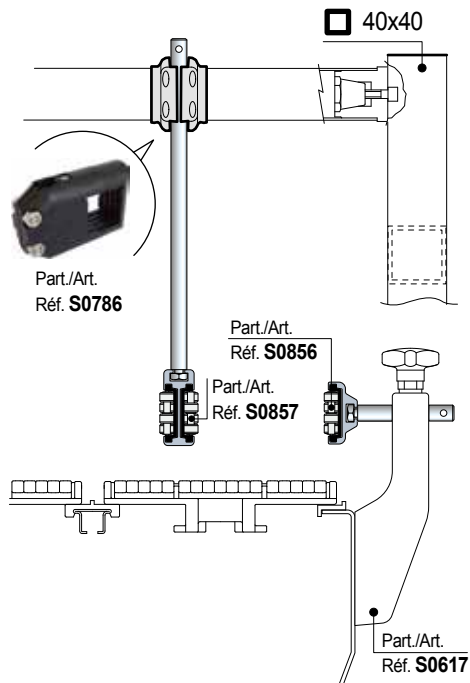
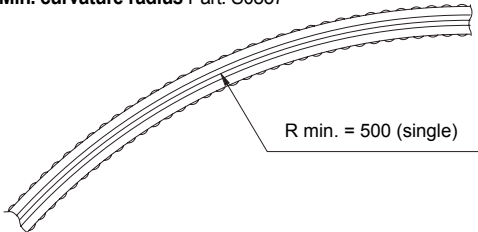

Roller centre guides

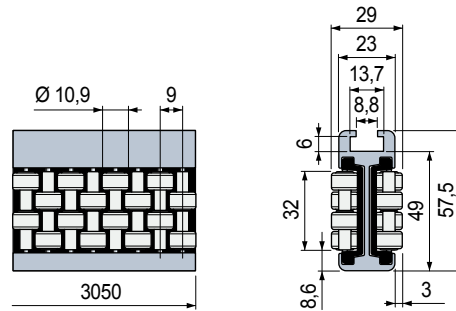

Part. S0857



Rollers material	Code	Weight kg
Acetal POM (white)	645223	1,75

- Material: metal profile in anodized aluminium, rollers module in acetal POM (black), roller pins in stainless steel.
- Standard packaging: strands 3,05 metres.
- Packaging: 2 strands.

Part. S0760

■ Side separation block

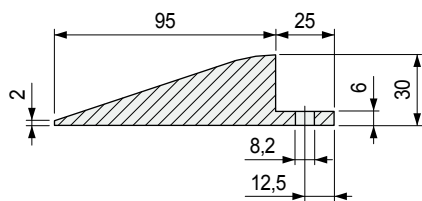

Code	Weight kg
613433	0,05

- Material: separation block in Polyethylene PE (white), bolt in austenitic stainless steel.
- Packaging: 2 pieces.

• Assembly Part. S0760

Part./Art./Réf. **S0757 - S0868 - S0756 - S0856**

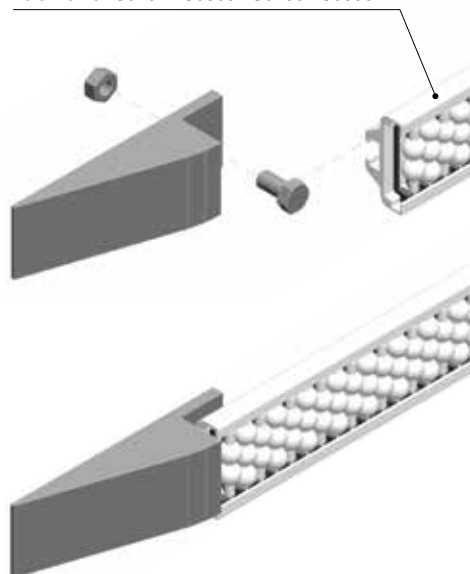

• **Assembly** Part. S0852

Part./Art./Réf. **S0757 - S0755 - S0868 - S0869**
S0756 - S0754 - S0856 - S0857 - S0656

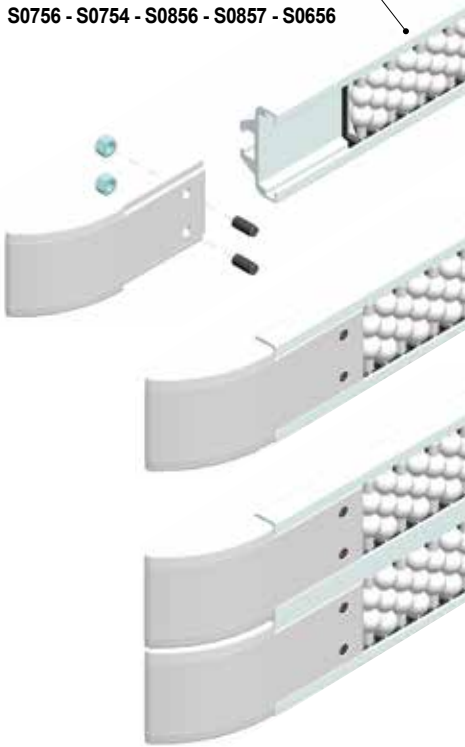

■ **Side separation block**

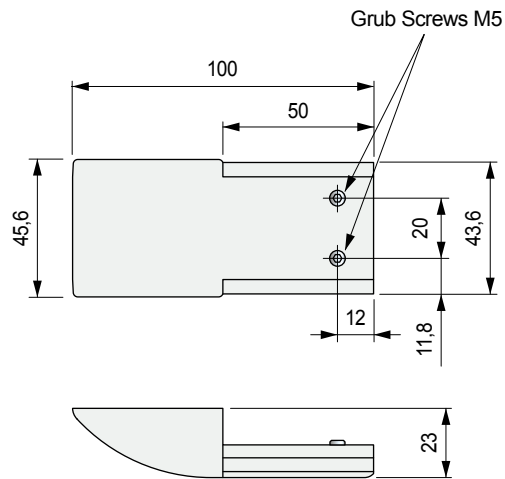

Code	Weight kg
646633	0,05

- Material: separation block in Acetal POM (white), nuts in nickel plated brass, grub screws in stainless steel.
- Packaging: 4 pieces.

Part. S0852



• **Assembly** Part. S0854

Part./Art./Réf. **S0757 - S0755 - S0868 - S0869**
S0756 - S0754 - S0856 - S0857 - S0656

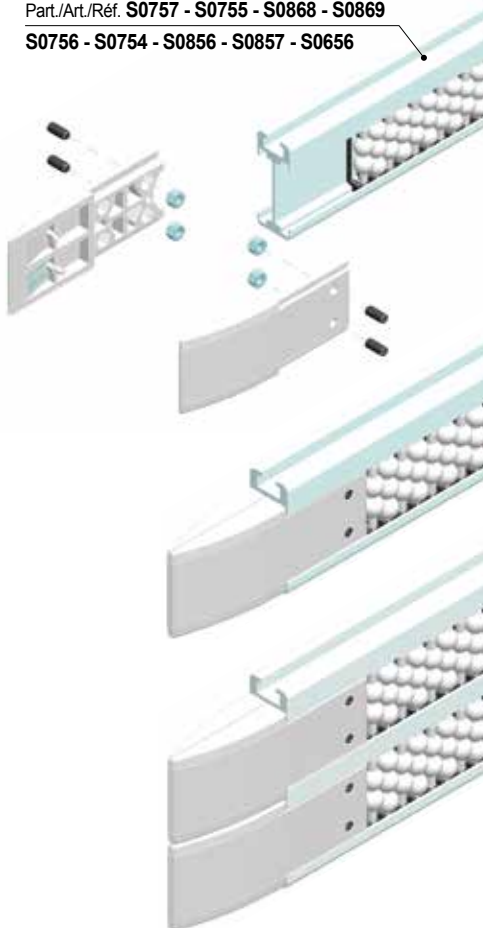

■ **Centre separation block**

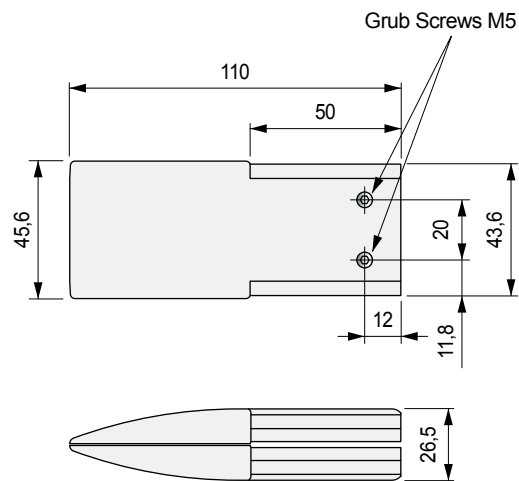

Code	Weight kg
646643	0,09

- Material: separation block in Acetal POM (white), nuts in nickel plated brass, grub screws in stainless steel.
- Packaging: 4 pairs.

Part. S0854



Part. S0128S

Sideflexing



■ Roller side guides

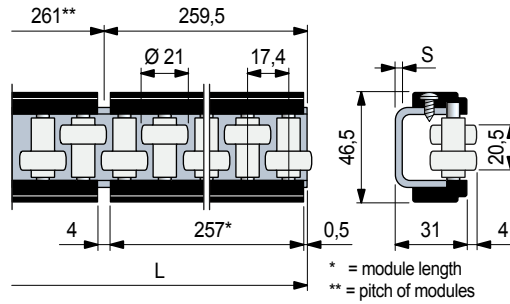

S mm	L mm	Metal profile and screws material	Code	Weight kg/m
Part. S0128S Sideflexing				
2	3129	Zinc plated steel	6346600	2,06
Part. S0128 Straight run				
	1041	Zinc plated steel	64531	
3	2085	Zinc plated steel	64541	2,6
	3129	Austenitic stainless steel	63350	

- Material: rollers in acetal POM (white). Side straps in polyamide PA (black). Roller pins in ferritic stainless steel.
- Packaging: 2 strands.
- Accessories:



Part. S0128

Straight run



■ Roller side guides

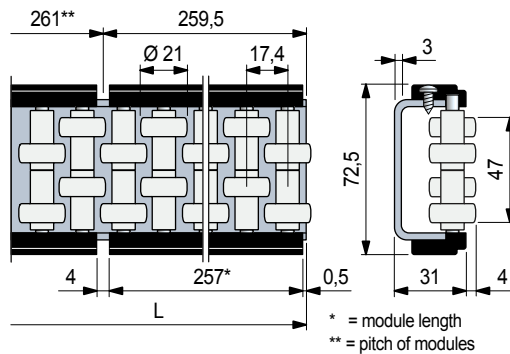

L mm	Metal profile and screws material	Code	Weight kg/m
1041	Zinc plated steel	64501	
3129	Austenitic stainless steel	63340	3,8

- Material: rollers in acetal POM (white). Side straps in polyamide PA (black). Roller pins in ferritic stainless steel.
- Packaging: 2 strands.
- Accessories:



- Use of Part. S0128S - S0128 Rugged containers (ex. cases, cartons).

• Modular system

Guides are made of 257 mm long modules fixed on a metal "C" profile.

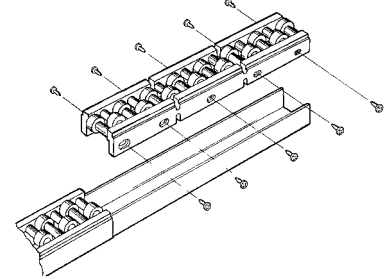

- Min. curvature radius (only for Part. S0128S)

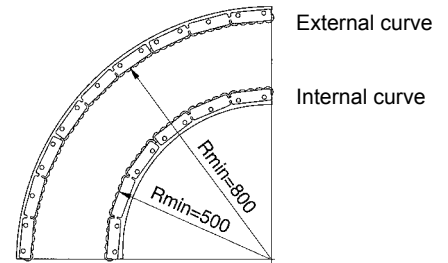

Curving procedure

- Disassemble the modules
- Curve the metal profile using the manual bending machine.
- Reassemble the modules (the flexibility of the side straps make them easily adaptable to the curved profile).

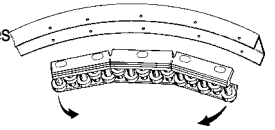

- Deflection of Part. S0128S - S0128

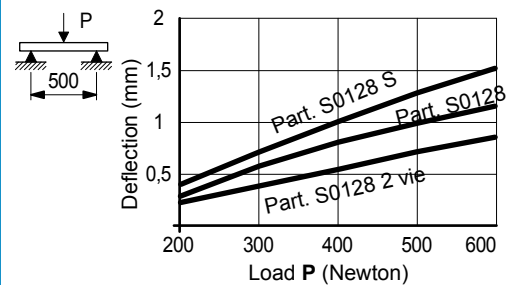

- Use of Part. S0128 Rugged containers (ex. cases, cartons).

• Modular system Part. S0128

Guides are made of 257 mm long modules fixed on a metal "C" profile.

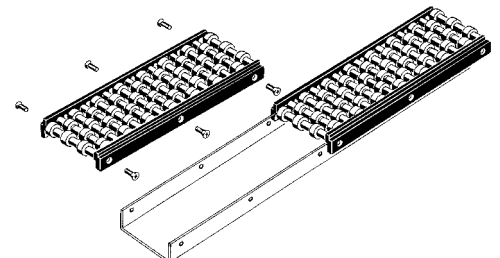

- **Use of Part. S0128**
Rugged containers (ex. cases, cartons).

- **Modular system**
Guides are made of 257 mm long modules fixed on a metal "C" profile.

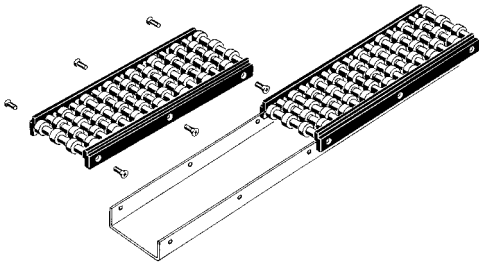

- **Deflection of Part. S0128**

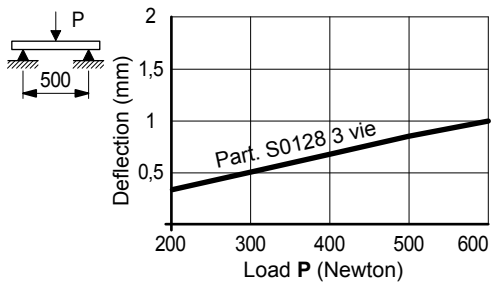

Roller side guides

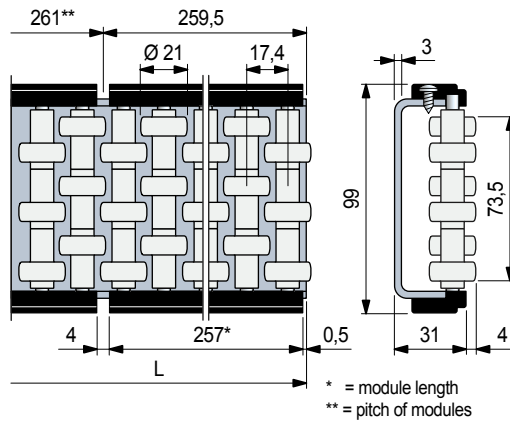

Part. S0128

Straight run



L mm	Metal profile and screws material	Code	Weight kg/m
1041	Austenitic stainless steel	62660	5,0
2085	Austenitic stainless steel	62690	
	Zinc plated steel	64491	
3129	Austenitic stainless steel	62890	

- Material: rollers in acetal POM (white).
Side straps in polyamide PA (black).
Roller pins in ferritic stainless steel.
- Packaging: 2 strands.
- Accessories:



Rollers

Part. S0063

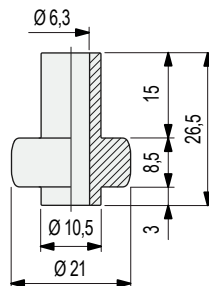

Code

S006351370

- Material: acetal POM (white).
- Packaging: Part. S0063 (500 pieces),
Part. S0063 can be used as spare part in roller guides Part. S0128-S0128 S-S0628 S.

Part. S0063



• Bending procedure

1 - Calculate the length of the section to be bent L.

$$L = R \cdot K$$

R = bend radius.

K = bend coefficient.

bend angle (degrees)	30°	60°	90°	120°	150°	180°
bend coefficient K	0,5	1	1,5	2	2,5	3

2 - Sign the length L on the profile to be bent, with (X) starting point, (Z) end point and (Y) middle point. Acting on handle (M), displace roller (1) to contact the profile

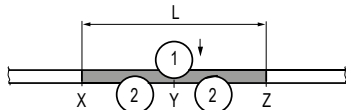

3 - Acting on handle (M), adjust the displacement to obtain the right radius (more displacement, smaller radius). Acting on handle (N), rollers (2) rotate and move the profile to position X (picture A) or Z (picture B). To obtain the desired radius it is necessary a minimum of two shifts.

To get a seamless transition from straight section to curve section and vice-versa it is necessary to exceed points X and Z by 20 mm.

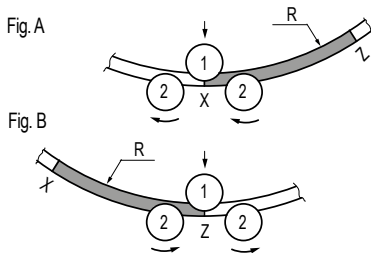

■ Guide rail bending machine (manual)

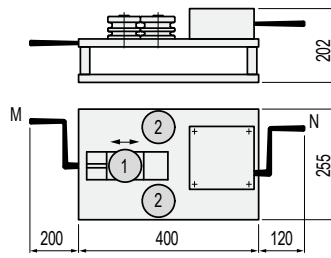

Part. S0218



Code

Weight
kg

60151

23

- Functioning: manual.
- Packaging: 1 bending machine.

- The bending machine is made with 3 shafts for rollers, hand driven.
- Handle (M), displaces roller (1), to determine the bending radius.
- Handle (N), actions the rotation of rollers (2).
- The rollers are supplied as separate accessories.
- Each type of guide needs specific rollers, according to the table below. Double groove rollers allow two profiles bending at one time.

- Both internal and external bends can be made.

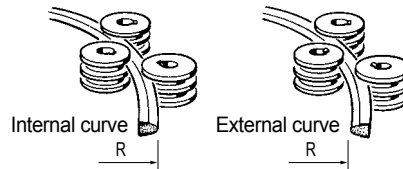

Guide - Rail Clamps for

- Part. S0223
- Part. S0317
- Part. S0219
- Part. S0273
- Part. S0308
- Part. S0715
- Part. S0765
- Part. S0767
- Part. S0768
- Part. S0769
- Part. S0770

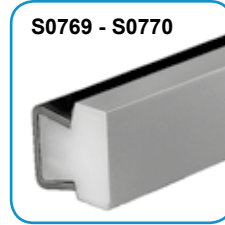
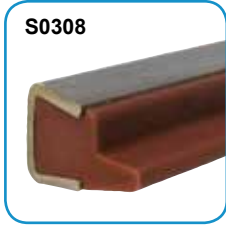
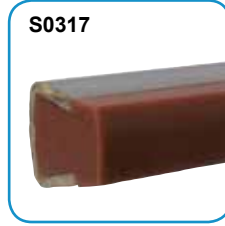

Part. S0210P



Guide rail clamp

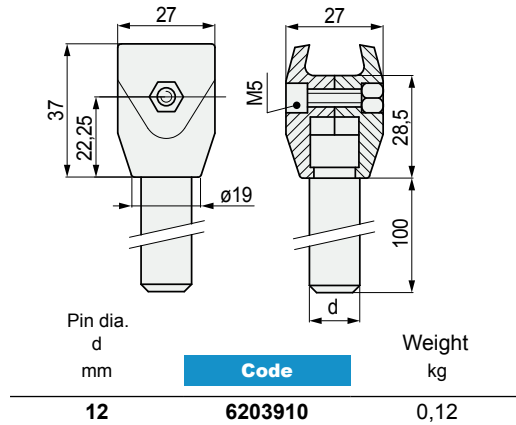

- Material: guide rail clamps in reinforced polyamide PA FV (black). Pin in austenitic stainless steel. Bolt in austenitic stainless steel. Nut in nickel plated brass.
- Packaging: 24 pieces.

Pin dimensions for Part. S0210

Pin dia. 12 mm

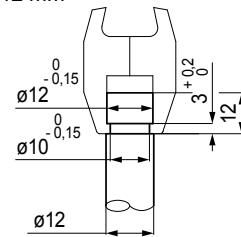

Pin dia. 14 mm

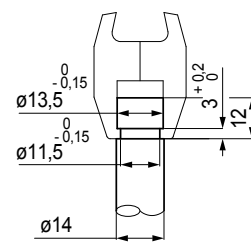

for Part. S0223 - S0317 - S0219 - S0273 - S0308 - S0715 - S0765 - S0767 - S0768 - S0769 - S0770

• Assembly of Part. S0275

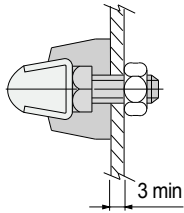

* = Steel reinforcement plate

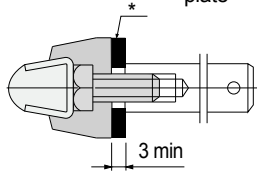

• Assembly of Part. S0211

Unlimited height adjustment possible

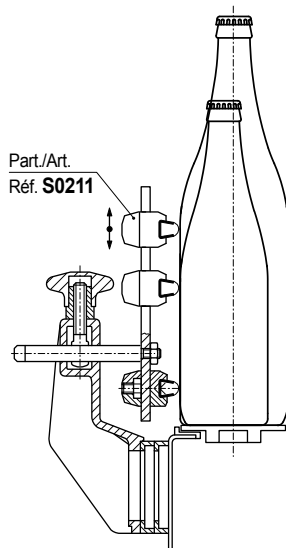

■ Guide rail clamp

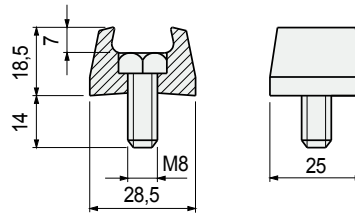

Part. **S0275**



Code	Weight kg
66811	0,02

- Material: guide rail clamps in acetal POM (Black), bolt in austenitic stainless steel.
- Packaging: 50 pieces.

■ Adjustable guide rail clamp

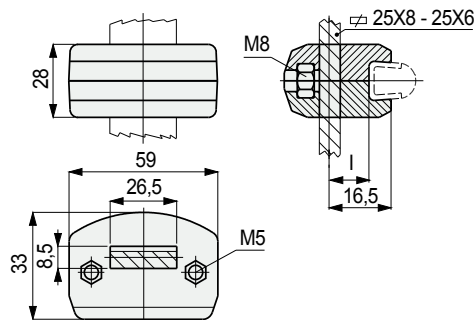

Part. **S0211**



Distance l = 8 mm

l mm	Code	kg
8	59961	0,05

- Material: guide rail clamps in reinforced polyamide PA FV (black).
- Bolt in austenitic stainless steel. Nut in nickel plated brass.
- Packaging: 24 pieces.

for Part. S0223 - S0317 - S0219 - S0273 - S0308 - S0715 - S0765 - S0767 - S0768 - S0769 - S0770

Part. S0213



Double guide rail clamp

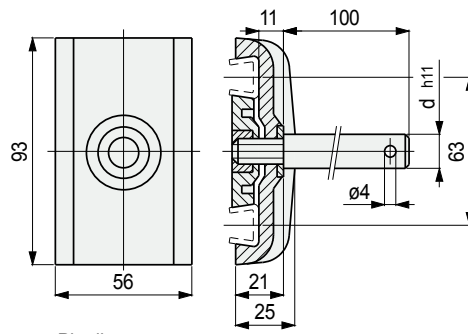

Pin dia.
d
mm

Weight
kg

Pin dia. d mm	Code	Weight kg
12	60091	0,19

- Material: guide rail clamp in reinforced polyamide PA FV (black).
Pin in austenitic stainless steel.
Washer in austenitic stainless steel.
Nut in nickel plated brass.
- Packaging: 24 pieces.

• Assembly of Part. S0213

The plate inside the clamp must be positioned to suit the thickness of the guide.

Position of plate for assembly of guides of thickness s = 1,5.

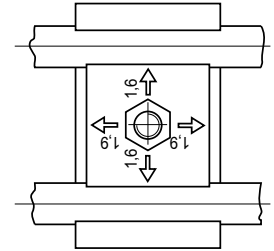

Position of plate for assembly of guides of thickness s = 2.

The plate is turned through 90°.

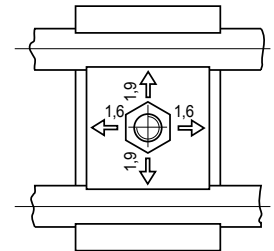

Part. S0213



Double guide rail clamp

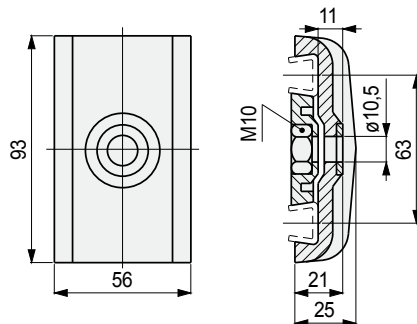

Weight
kg

Code	Weight kg
60101	0,08

- Material: guide rail clamp in reinforced polyamide PA FV (black).
Washer in austenitic stainless steel.
Nut in nickel plated brass.
- Packaging: 24 pieces.
- Accessories: swivel pin connection Part. S0749 - S0740P.

for Part. S0219 - S0273

• **Assembly of Part. S0736**

The clamps allows the junction of straight tracks with corner tracks.
Ideal to adjust the length of side guides near the curves when width adjustment is needed.

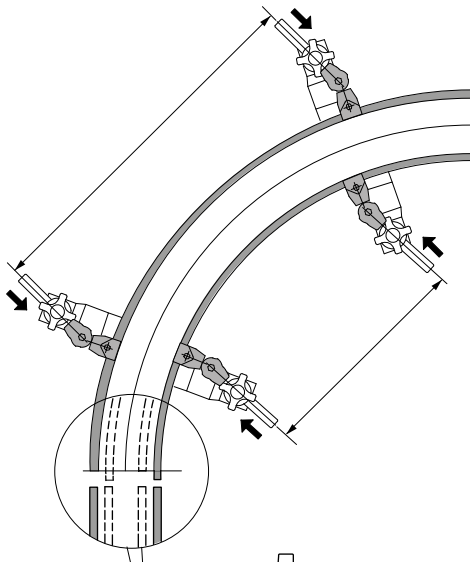

Part./Art.
Réf. **S0273**

Part./Art.
Réf. **S0219**

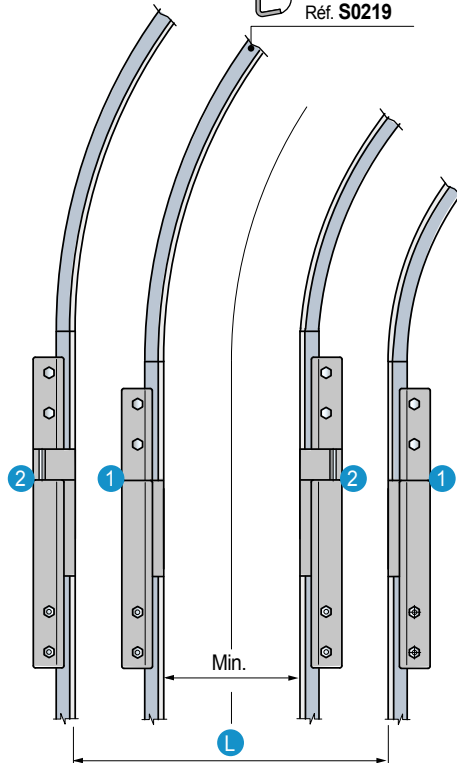

- 1 - Closed clamp.
- 2 - Open clamp.
- L - Size changing width.

■ **Sliding joint clamp**

Clamp fully closed

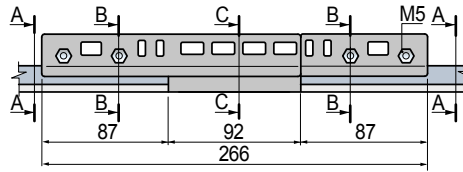

Clamp fully open

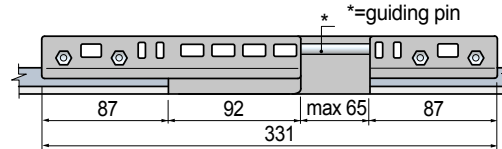

■ **Part. S0736 - Sliding joint clamp for Part. S0219**

Part./Art.
Réf. **S0219-
S0219XLF**



Sez./Sec.
SeK. A-A

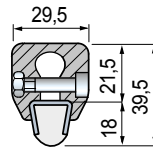

Sez./Sec.
SeK. B-B

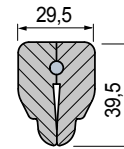

Sez./Sec.
SeK. C-C



■ **Part. S0737 - Sliding joint clamp for Part. S0273**

Part./Art.
Réf. **S0273**



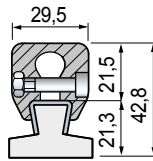

Sez./Sec.
SeK. A-A

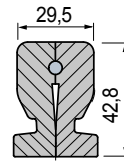

Sez./Sec.
SeK. B-B



Sez./Sec.
SeK. C-C

Type of guides to joint	Code	Weight kg
 Part. S0219 - S0219XLF	S0736695402	0,24
 Part. S0273	S0737695412	

- Material: clamp in acetal (white).
- Guiding pin in austenitic stainless steel.
- Tightening bolt in austenitic stainless steel.
- Max recommended tightening torque: 0,4 Kgm.
- Packaging: 1 piece.

for Part. S0223 - S0317 - S0219 - S0273 - S0308 - S0715 - S0765 - S0767 - S0768 - S0769 - S0770

Part. S0694

■ Guide-rail clamp



With two fixing screws

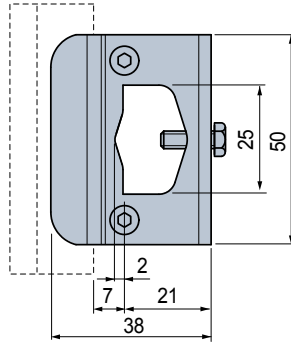
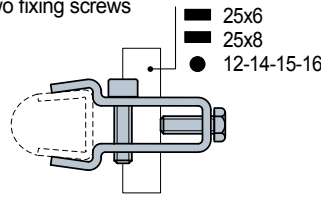

Code	Weight kg
689222	0,10

- Material: clamp and bolt in austenitic stainless steel.
- Packaging: 16 pieces.

Part. S0217

■ Guide-rail clamp (double)

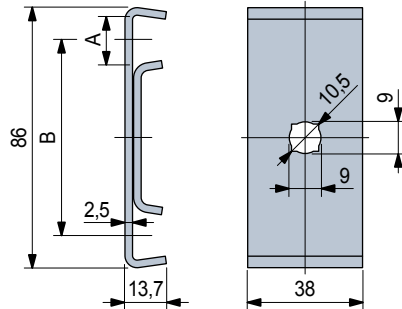

Use	A mm	B mm	Code	Weight kg
For guides width S = 2	17	63,5	695131	0,14

- Material: austenitic stainless steel.
- Packaging: 50 pieces.
- Accessories: swivel pin connection Part. S0740 - S0740P.

• Assembly of Part. S0694

Fixing on plates

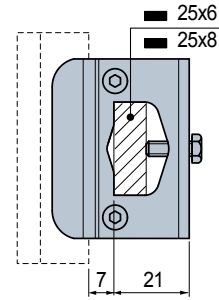

Fixing on rods

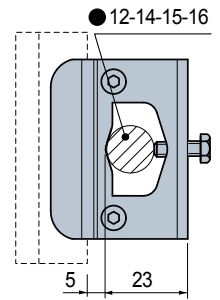

25x6
25x8

12-14-15-16

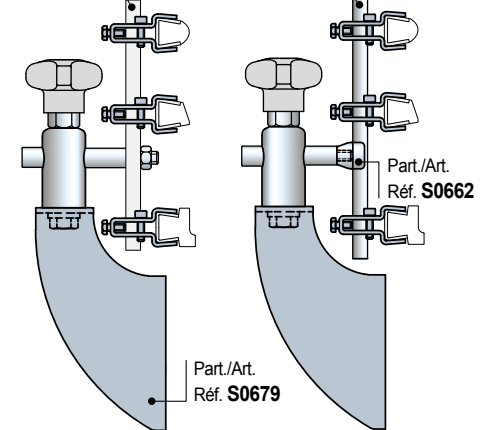

• Pin dimensions for Part. S0217

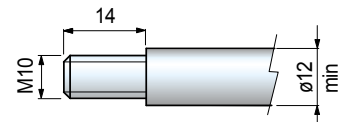

Part./Art.
Réf. S0217

Part./Art.
Réf. S0217

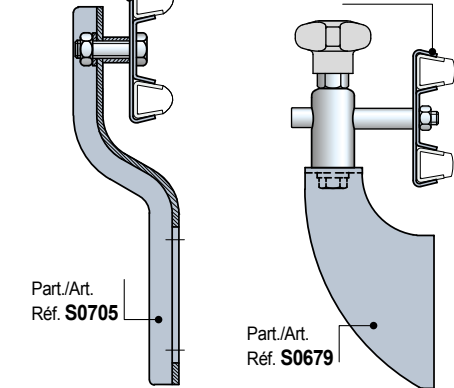

Guide - Rail Clamps

for Part. S0223 - S0317 - S0219 - S0273 - S0308 - S0715 - S0765 - S0767 - S0769 - S0770

• Assembly of Part. S0903

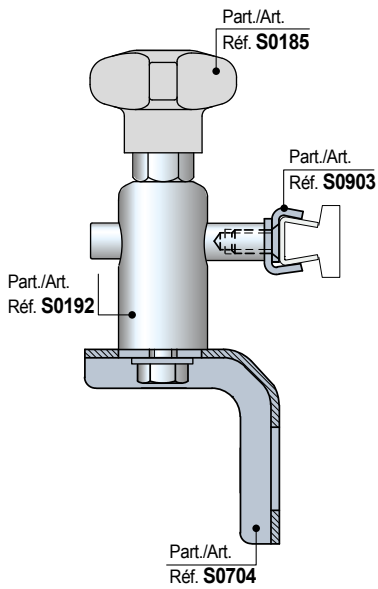
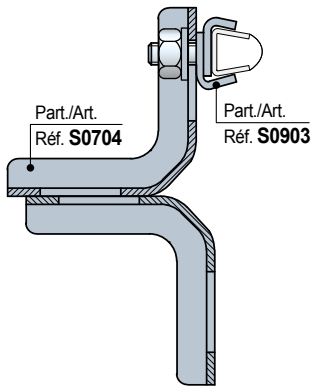

• Assembly of Part. S0215

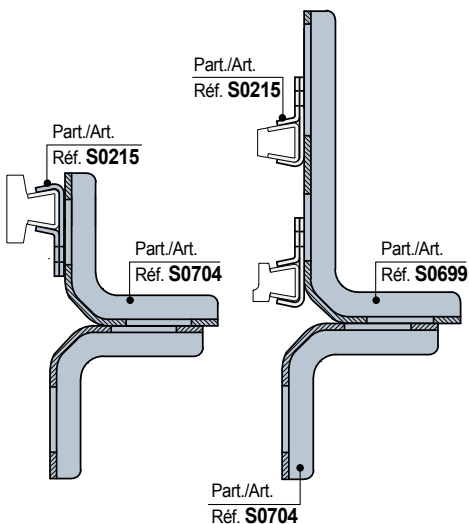

■ ViseClamp™

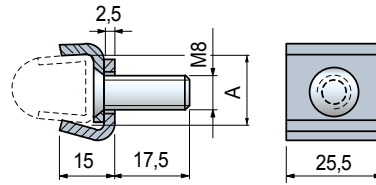

Part. S0903



Use	A mm	Code
For guides width S = 2	17	656001N

- Material: austenitic stainless steel.
- Packaging: 50 pieces.

■ Guide rail clamp

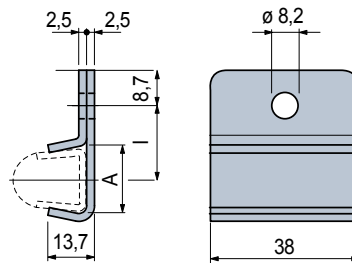

Part. S0215



Use	A mm	l mm	Code	Weight kg
For guides width S = 1,5	16	20,5	60121N	0,04
For guides width S = 2	17	20	65976N	

- Material: austenitic stainless steel.
- Packaging: 50 pieces.

Part. **S0237**



■ Adjustable guide-rail clamp

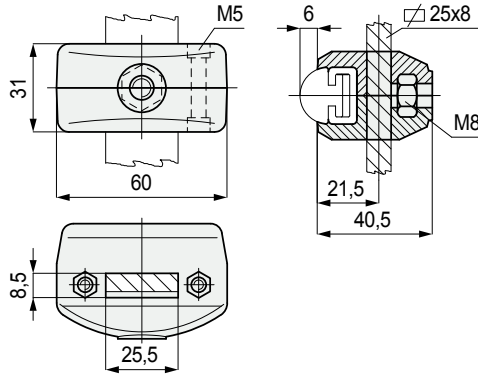

Code	Weight kg
63151	0,06

- Material: guide rail clamp in reinforced polyamide PA FV (black).
- Bolts in austenitic stainless steel. Nuts in nickel plated brass.
- Packaging: 24 pieces.

• Assembly of Part. S0237
Unlimited height adjustment possible

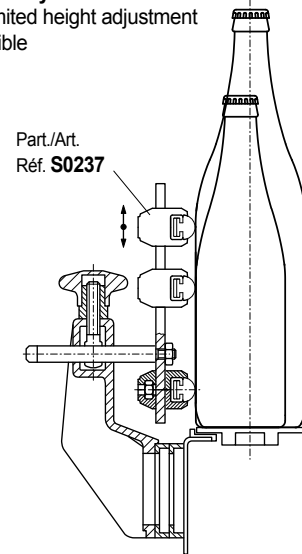

Part. **S0247**



■ Guide rail (round)

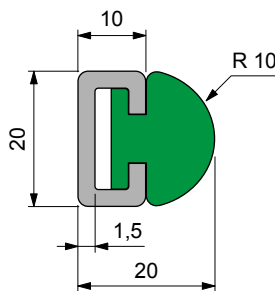

Length metres	Metal profile material	Code	Weight kg/m
Plastic profile material in polyethylene UHMWPE (green)			
3	Austenitic stainless steel	63911	0,67
	Zinc plated steel	63921	

- Min. curvature radius: 145 mm.
- Linear expansion coefficient: $2 \times 10^{-4} \text{ } ^\circ\text{C}^{-1}$.
Calculation of thermal expansion see Technical information.
- Accessories:

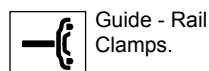

Guide - Rail Clamps for
• Round steel rods

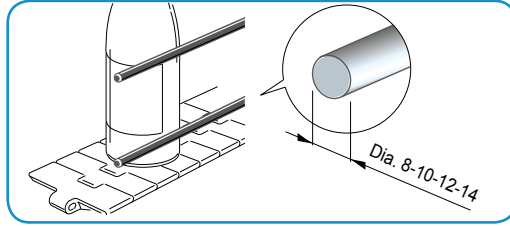

Part. S0082P

■ Guide-rail clamp

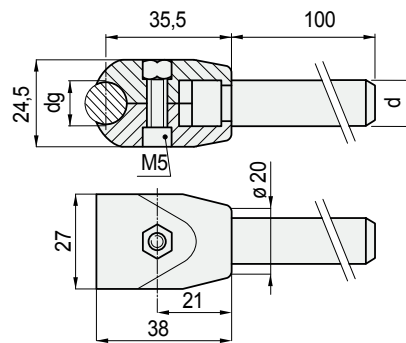

pin dia. d mm	Guide dia. dg mm	Code	Weight kg
12	12	6184910	0,12

- Material: guide rail clamps in reinforced polyamide PA FV (black).
- Pin in austenitic stainless steel.
- Bolt in austenitic stainless steel. Nut in nickel plated brass.
- Packaging: 24 pieces.

Guide - Rail Clamps

for round steel Rods

- Assembly of Part. S0159
PET bottle movement
(subject to swelling).

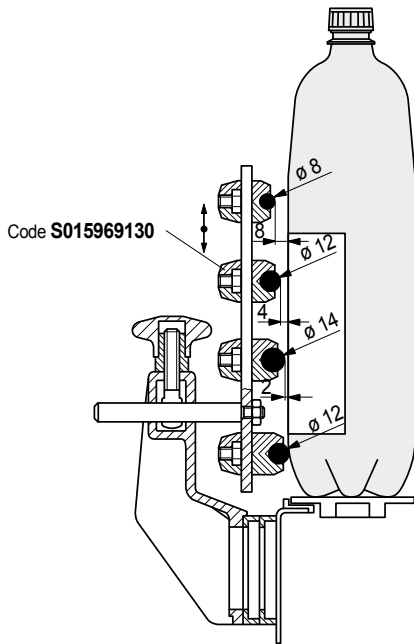

Adjustable guide-rail clamp

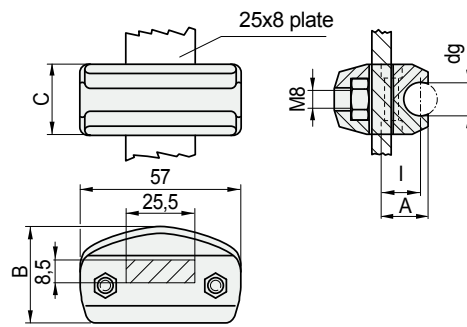

Guide dia.

dg mm	I mm	A mm	B mm	C mm	Code	Weight kg
10	12	15,8	32,5	21	S0159622381	0,05
12	14	17,8	35	25	S015969130	

- Material: guide rail clamp in reinforced polyamide PA FV (black).
Bolts in austenitic stainless steel. Nuts in nickel plated brass.
- Packaging: 24 pieces.

Part. S0159



For 25 x 8 plates

for round steel Rods

Part. S0071

Double guide-rail clamp

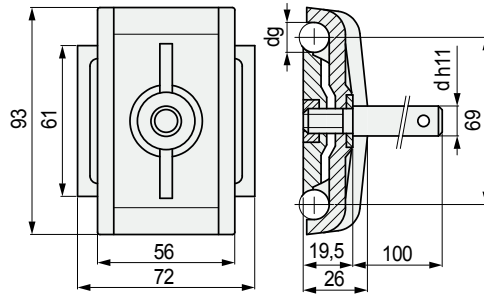

pin dia. d mm	Guide dia. dg mm	Code	Weight kg
12	12	50960	0,20

- Material: guide rail clamp in reinforced polyamide PA FV (black).
- Pin in austenitic stainless steel.
- Washer in austenitic stainless steel.
- Nut in nickel plated brass.
- Packaging: 24 pieces.

Part. S0070

Double guide-rail clamp

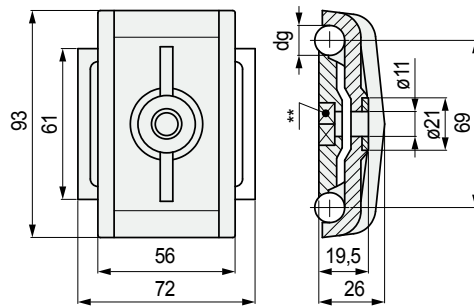

** = Seat for nut M10
UNI 5588

Pin dia. d mm	Code	Weight kg
12	50950	0,09

- Material: guide rail clamps in reinforced polyamide PA FV (black).
- Washer in austenitic stainless steel.
- State of supply: supplied without tightening nut.
- Packaging: 24 pieces.
- Accessories: swivel pin connection.

- **Swivel pin connection** Part. S0740 - S0740P
Use for conveyors with (format change).
They allow an easy regulation of product-guides on corner tracks.
See page S112.

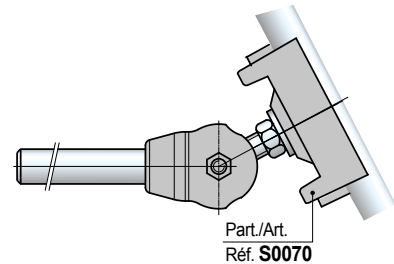

Guide - Rail Clamps

for round steel Rods

• Assembly of Part. S0698

Fixing on plates

Fixing on rods

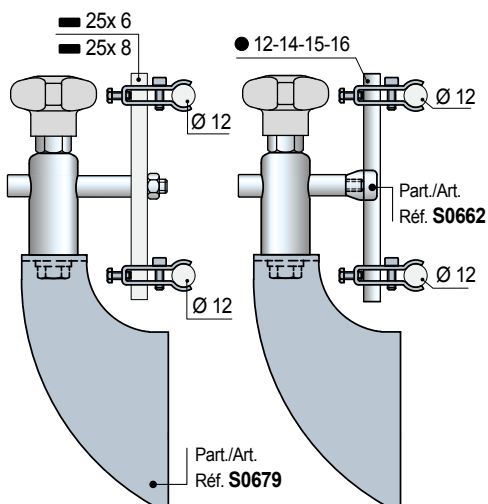
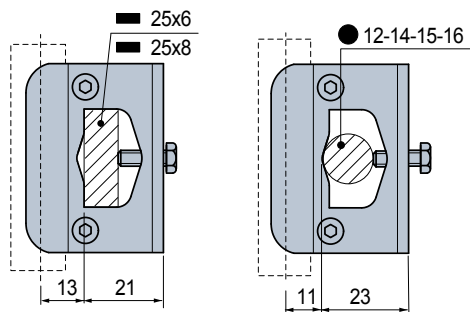

• Assembly of Part. S0662

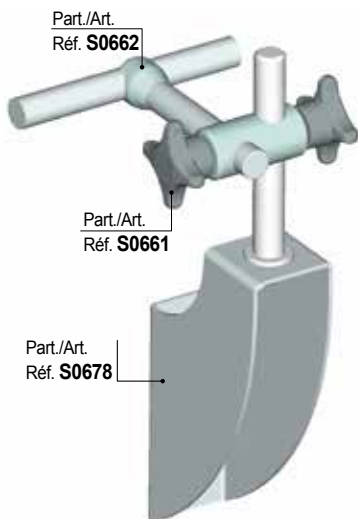

■ Guide-rail clamp

With two fixing screws

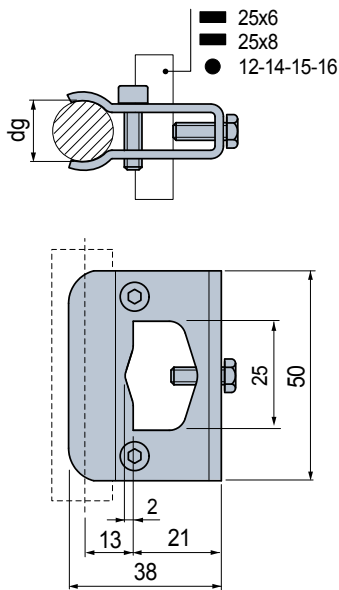

Guide dia. d mm	Code	Weight kg
12	689202	0,10

- Material: clamp and bolt in austenitic stainless steel.
- Packaging: 16 pieces.

Part. **S0698**



■ Guide-rail clamp

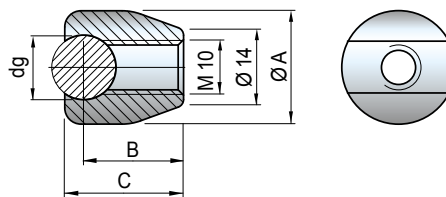

Guide dia. dg mm	Code	dia. A mm	B mm	C mm	Weight kg
12	669552	21	18,5	22	0,03

- Material: austenitic stainless steel.
- Packaging: 10 pieces.

Part. **S0662**



Part. S0050

■ Double guide-rail clamp

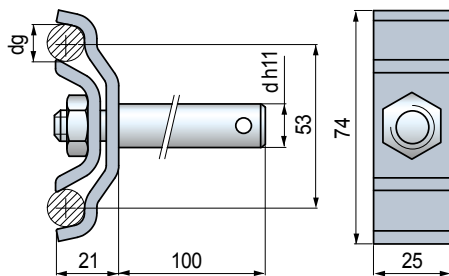

Guide dia. dg mm	pin dia. d mm	Code	Weight kg
12	12	53801	0,34
	14	51000	0,36

- Material: guide rail clamp and tightening nut in austenitic stainless steel. Pin in austenitic stainless steel.
- Packaging: 12 pieces.

• Assembly of Part. S0050

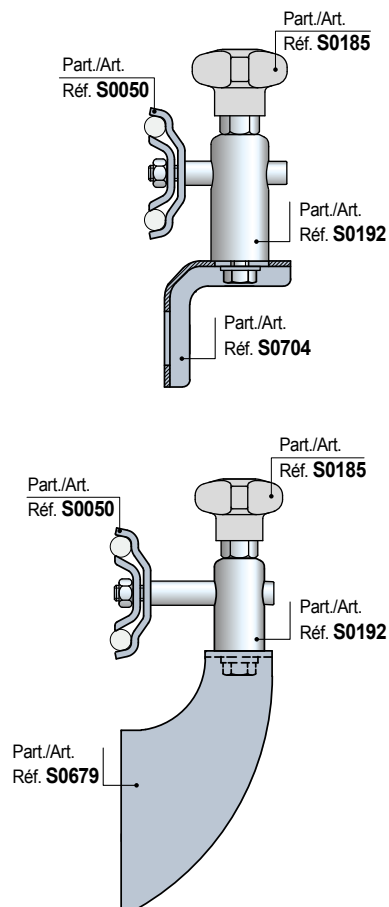

Guide - Rail Clamps for
• Part. S0191



Part. **S0190**



■ Guide-rail clamp

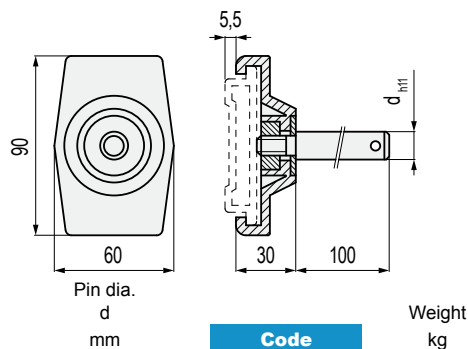

Pin dia. d mm	Code	Weight kg
12	55741	0,18

- Material: guide rail clamp in reinforced polyamide PA FV (black). Pin in austenitic stainless steel. Washer in austenitic stainless steel. Nut in nickel plated brass.
- Packaging: 24 pieces.
- Suitable to use in curves also.

• Assembly of Part. S0190

The protrusion of the pin allows the guide to be locked axially.

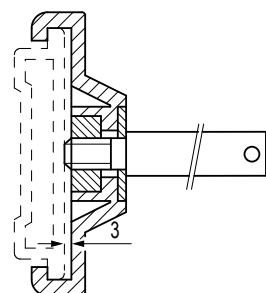

Part. **S0184**



■ Guide-rail clamp

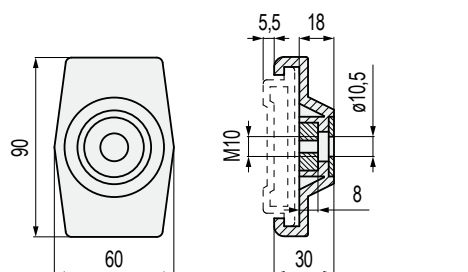

Code	Weight kg
54961	0,09

- Material: guide rail clamp in reinforced polyamide PA FV (black). Washer in austenitic stainless steel. Nut in nickel plated brass.
- Packaging: 24 pieces.
- Suitable to use in curves also.

Guide - Rail Clamps for • Part. S0296

S0296



• Assembly of Part. S0298

- 1) Untighten the screws
- 2) Clip on to the profile
- 3) Slide along the guide to the desired position and tighten screws to lock in place.

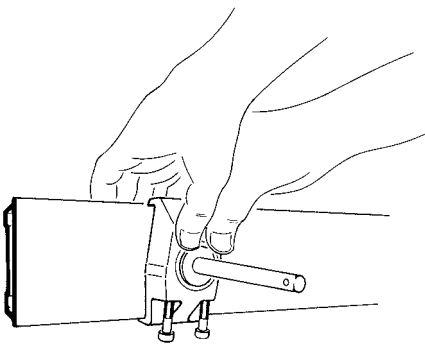
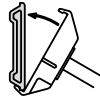

■ Guide-rail clamp

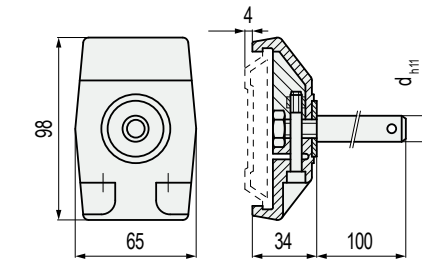

Pin dia. d mm	Code	Weight kg
12	60372	0,12

- Material: guide rail clamp in reinforced polyamide PA FV (black). Pin in austenitic stainless steel. Washer in austenitic stainless steel. Nut in nickel plated brass.
- Packaging: 24 pieces.
- Suitable to use in curves also.

Part. S0298



■ Guide-rail clamp

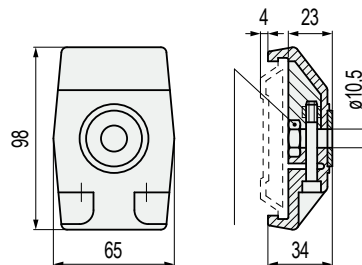

Code	Weight kg
60362	0,12

- Material: guide rail clamp in reinforced polyamide PA FV (black). Washer in austenitic stainless steel. Nut in nickel plated brass.
- Packaging: 24 pieces.
- Suitable to use in curves also.

Part. S0298



Part. S0708



■ Bracket with two holes

Version without positioning guide

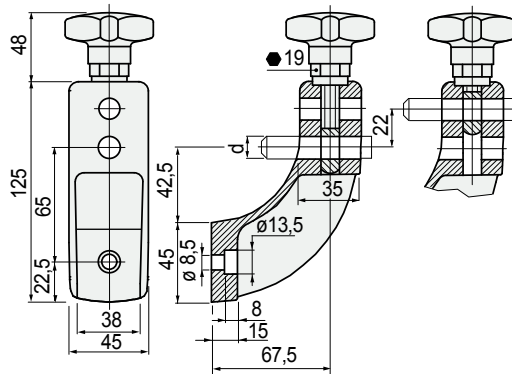

Pin dia.
d
mm

Code

Weight
kg

Version without positioning guide

Pin dia. d mm	Code	Weight kg
12	692502	0,23

- Material: bracket and knob in reinforced polyamide PA FV (black).
- Hexagonal insert (for 19 mm wrench) in nickel plated brass.
- Eyebolt in austenitic stainless steel.
- Max recommended tightening torque: 4 Kgm.
- Packaging: 12 pieces.

• Characteristics of Part. S0708

- Bracket with a reduced structure-connecting size.
- Available with positioning guide for an easy assembly on aluminium sections.
- The two holes allows to position the guide-rail bracket in two different heights depending on specific requirements.

• Assembly version with positioning guide

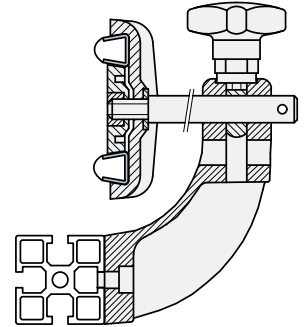

• Assembly version without positioning guide

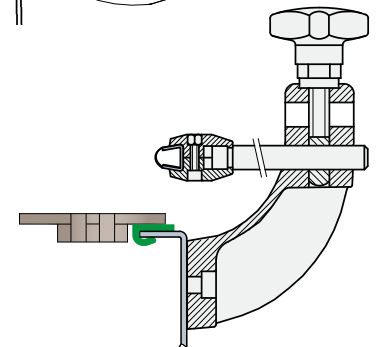
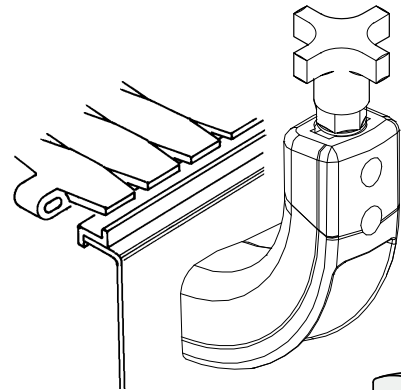

• Assembly version with centering pin

Deflection of Part. S0107

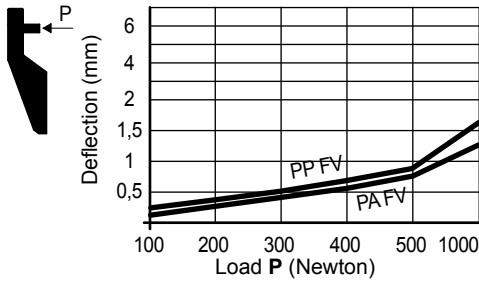

Technical data Part. S0107

- Sliding load resistance: - Breaking load:

Material in PA FV 2000 N (width d = 12) 3200 N (width d = 14)	Material in PA FV 4500 N
Material in PP FV 1300 N (width d = 12) 1700 N (width d = 14)	Material in PP FV 3300 N

Tests performed at tightening torque: 4 Kgm

Accessories

Spacer Part. S0061.
Applicable to Part. S0107

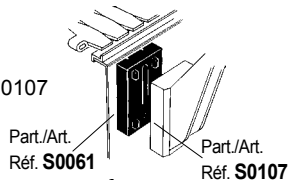

Spacer Part. S0142.
Applicable to Part. S0599

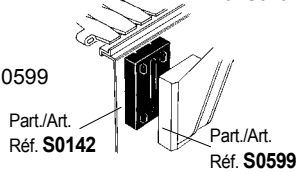

Assembly of drip tray support

Part. S0226 - S0336.
Part. S0107 e S0599
permit application of drip
tray support.

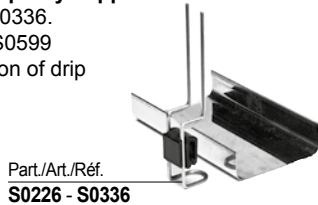

• Use Part. S0599
Same dimensions
as Part. S0163 - S0178 -
S0257, can be used
alternatively.

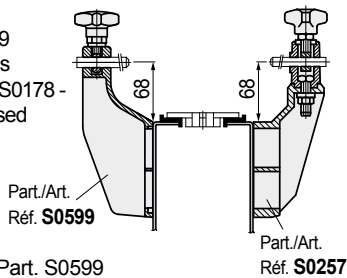

Deflection of Part. S0599

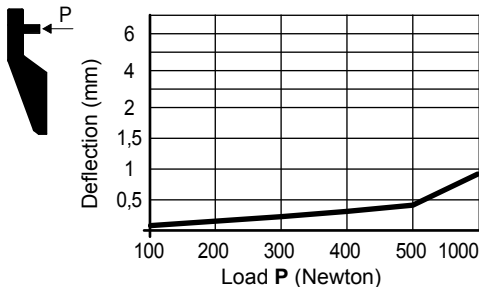

Technical data Part. S0599

- Sliding load resistance: - Breaking load:

2000 N (width d = 12)	3000 N
-----------------------	--------

Tests performed at tightening torque: 4 Kgm

Bracket with eyebolt

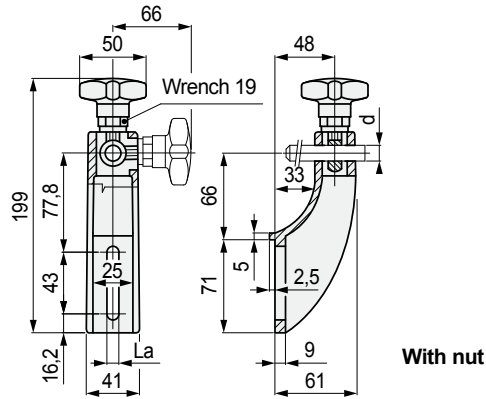

Material	Pin dia. d mm	Code		Weight kg
		La = 9	La = 10,5	

With lip

Reinforced polyamide PA FV	12	50710N	68200N	0,15
----------------------------	----	--------	--------	------

- Material: knob in reinforced polyamide (black), exagonal insert (for 19 mm wrench) in nickel plated brass, eyebolt in austenitic stainless steel.
- Colour: black.
- Max recommended tightening torque: 4 Kgm.
- Packaging: 12 pieces.

Part. S0107



Bracket with eyebolt

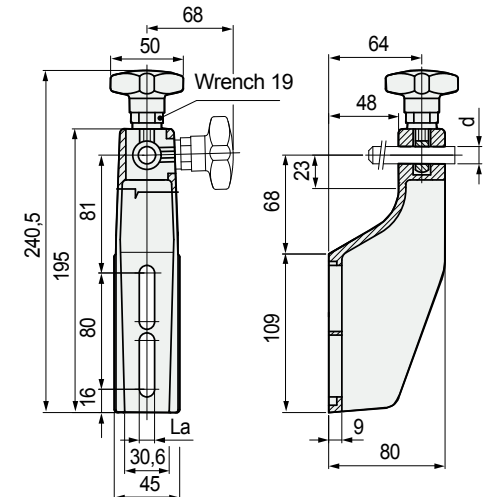

Material	Pin dia. d mm	Code		Weight kg
		La = 9	La = 10,5	

Reinforced polyamide PA FV	12	611293	613572	0,11
----------------------------	----	--------	--------	------

- Material: knob in reinforced polyamide (black), exagonal insert (for 19 mm wrench) in nickel plated brass, eyebolt in austenitic stainless steel.
- Colour: black.
- Max recommended tightening torque: 4 Kgm.
- Packaging: 12 pieces.

Part. S0599



Part. **S0617**



■ Bracket with eyebolt

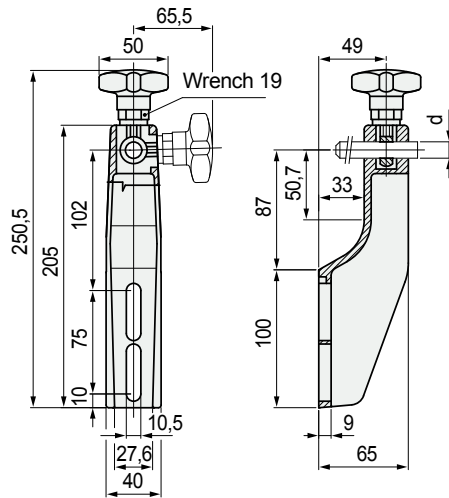

Material	Pin dia. d mm	Code	Weight kg
Reinforced polyamide PA FV (black))	12	613562	0,18

- Material: knob in reinforced polyamide (black), exagonal insert (for 19 mm wrench) in nickel plated brass, eyebolt in austenitic stainless steel.
- Max recommended tightening torque: 4 Kgm.
- Packaging: 12 pieces.

• Deflection of Part. S0617

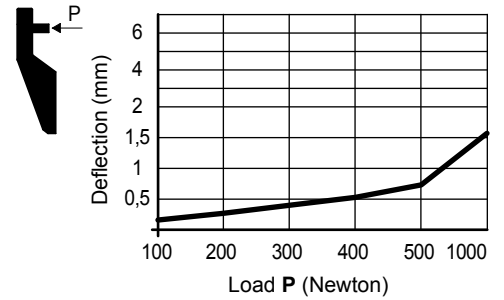

• Technical data Part. S0085

- Sliding load resistance: 2000 N (width d = 12)
- Breaking load: 3000 N

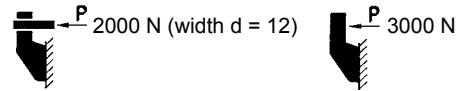

Tests performed at tightening torque: 4 Kgm

• Accessories

- Spacer Part. S0142. Applicable to Part. S0617 - S0140.

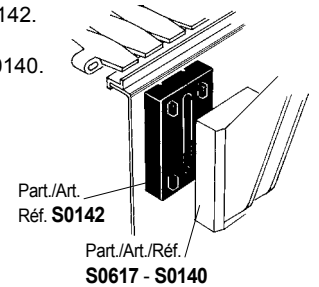

Part. **S0140**



■ Bracket with eyebolt

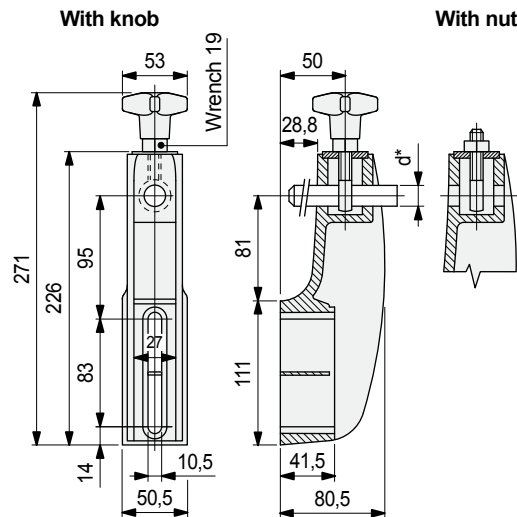

Pin dia. d* mm	Version	Code	Weight kg
14÷16	with knob	66690N	0,47

- * = The bracket can be used with dia. 14 and dia. 16 mm pins.
- Material: bracket and knob in reinforced polyamide (black), exagonal insert (for 19 mm wrench) in nickel plated brass, tightening nut and eyebolt in austenitic stainless steel.
- Max recommended tightening torque: 4 Kgm.
- Packaging: 12 pieces.

• Assembly of drip tray support

- Part. S0226 - S0336. Part. S0617 - S0140 permit application of drip tray support.

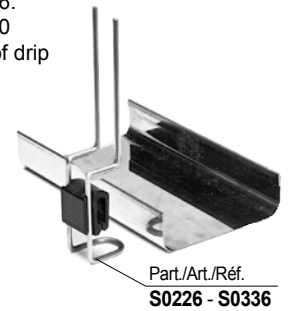

• Deflection of Part. S0140

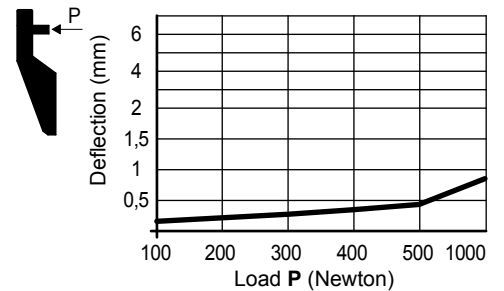

• Technical data Part. S0140

- Sliding load resistance: 3000 N (width d = 14-16)
- Breaking load: 12000 N

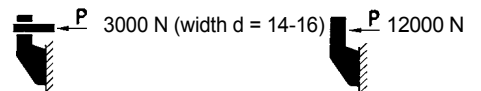

Tests performed at tightening torque: 4 Kgm

• **Assembly with swivel head Part. S0255**

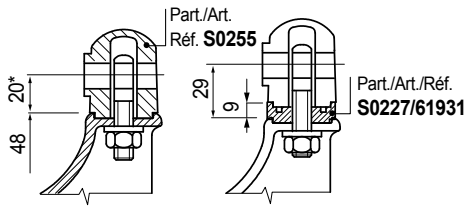

* = To increase the height (by 9 mm) use 1 spacer Part. S0227 code 61931. The length of the thread allows for only 1 spacer.

• **Assembly with swivel head Part. S0359**

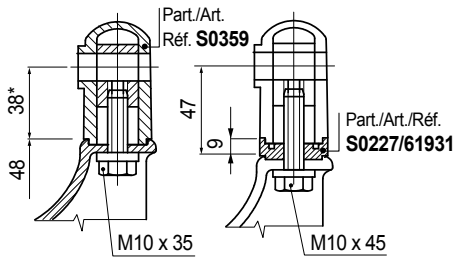

* = To increase the height (by 9 mm) use 1 or more spacer Part. S0227 code 61931. To use the spacer a longer screw is necessary.

• **Assembly with swivel head Part. S0256**

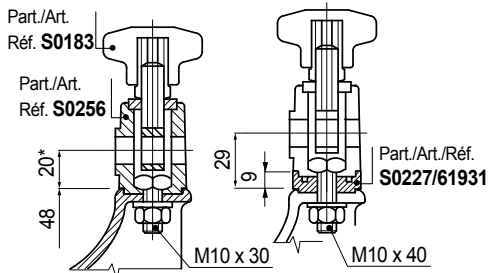

* = To increase the height (by 9 mm) use 1 or more spacer Part. S0227 code 61931. To use the spacer a longer screw is necessary.

• **Assembly with swivel head Part. S0192**

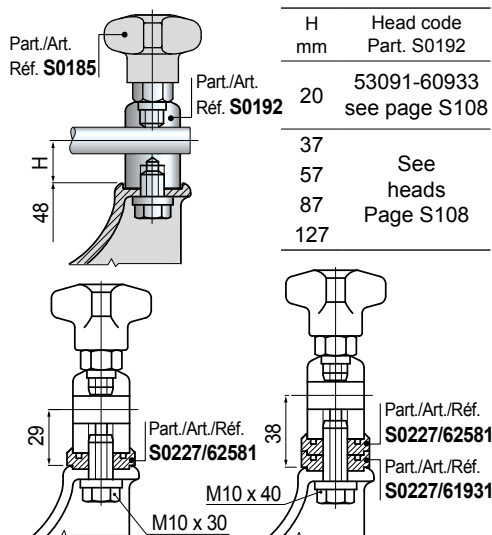

To use the spacer Part S0227, a longer screw is necessary.

■ **Adjustable bracket**

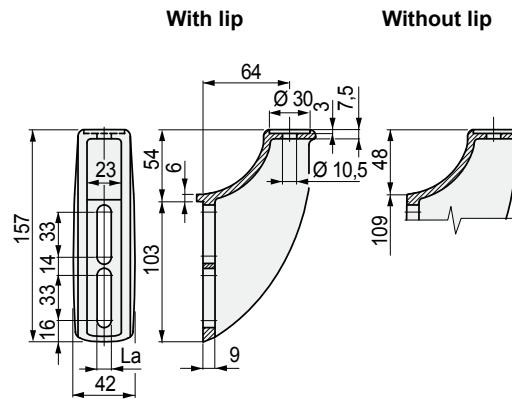

Part. S0632



Version	Code		Weight kg
	La = 9	La = 10,5	
Without lip	605263	647142	0,21

- Material: reinforced polyamide PA FV (black).
- Packaging: 12 pieces.
- Accessories: spacer Part. S0725.

• **Assembly Part. S0632**

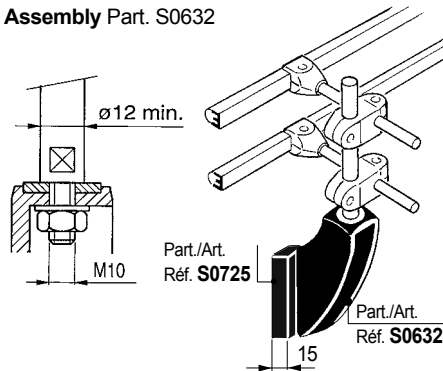

- Part. S0632 permit application of drip tray support Part. S0226 - S0336.

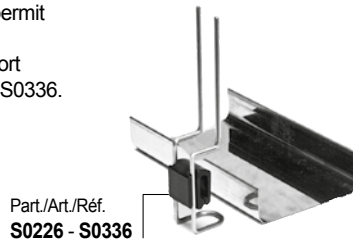

• **Deflection of Part. S0632**

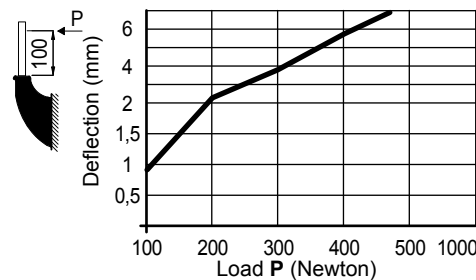

• **Breaking load P**

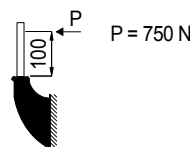

Part. **S0637**

Adjustable bracket

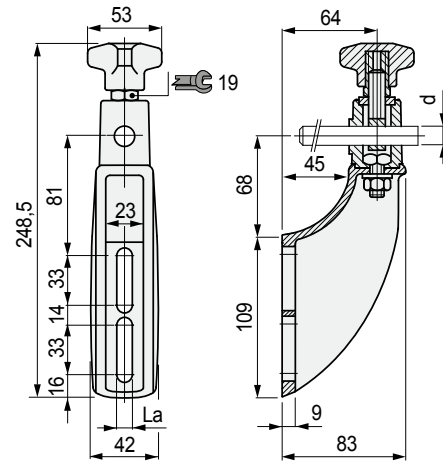

Pin dia. d mm	Code La = 10,5 mm	Weight kg
12	648372	
14	648382	0,40
16	648392	

- Material: bracket, swivel head and knob in reinforced polyamide (black), hexagonal insert (for 19 mm wrench) in nickel plated brass, eyebolt and tightening nuts/bolt in austenitic stainless steel.
- Operation: by untightening the bolt, the position of the top can be adjusted. By tightening the knob, the position of the pin can be adjusted.
- Max recommended tightening torque: 4 Kgm.
- Packaging: 12 pieces.

Deflection of Part. S0637 - S0638

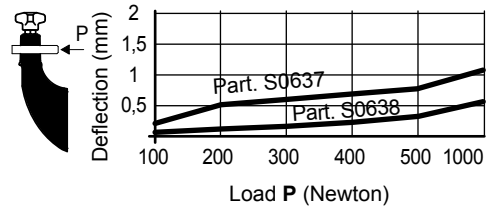

Technical data Part. S0637 - S0638

- Sliding load resistance: - Breaking load:

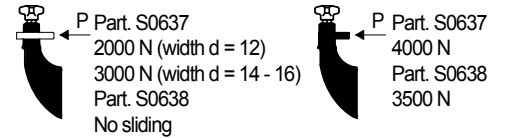

Tests performed at tightening torque: 4 Kgm

- Part. S0637 - S0638 permit application of 1 or more spacer Part. S0725.

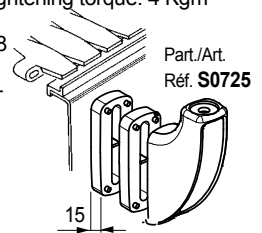

- Part. S0637 permit application of spacer Part. S0227.

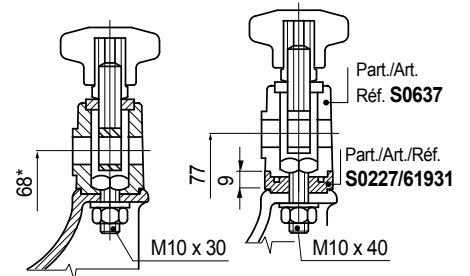

* = To increase the height (by 9 mm) use 1 spacer Part. S0227 code 61931. To use the spacer a longer screw is necessary.

To use the spacer Part. S0227 a longer screw is necessary.

- Part. S0226 - S0336. Part. S0637 and S0638 permit application of drip tray support.

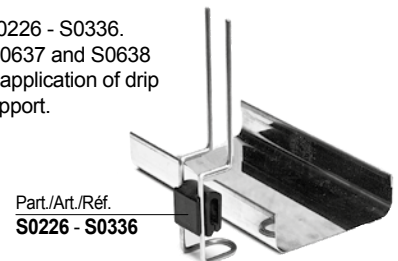

- **Assembly of Part. S0862**
Applicable to brackets Part. S0632 - S0648 - S0540

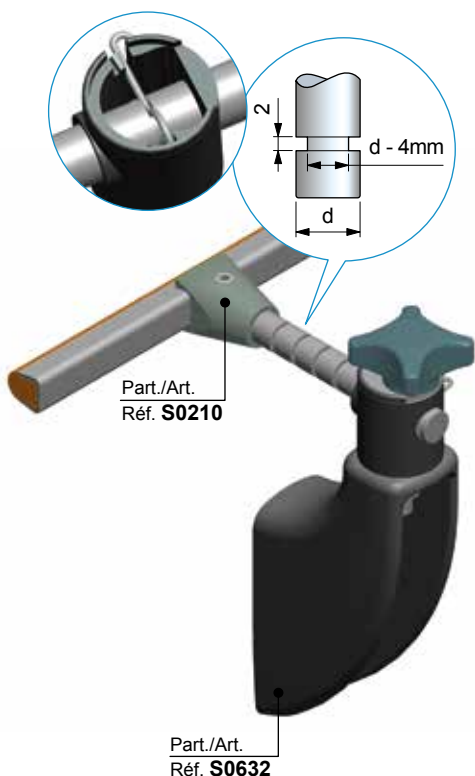

■ Swivel head

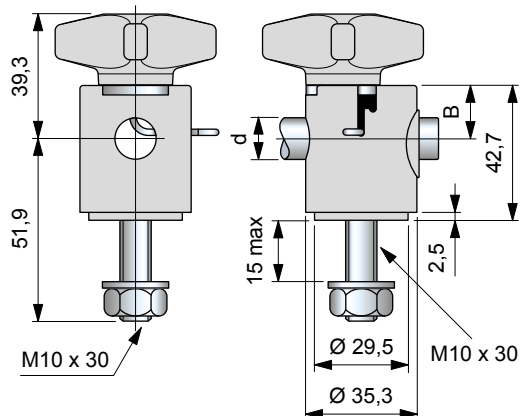

Pin dia. d mm	Pin dia. d inch	B	Code	Weight kg
12	1/2"	16,9	649763	0,08

- Material: clamp and knob in reinforced polyamide PA FV (black).
Tightening nut and eyebolt in austenitic stainless steel.
- Packaging: 12 pieces.

Part. **S0862**



- **Assembly of Part. S0256**
Applicable to brackets Part. S0632 - S0648 - S0540
(in combination with knob Part. S0183).

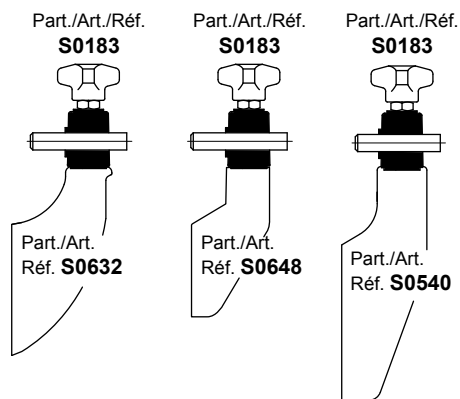

■ Swivel head

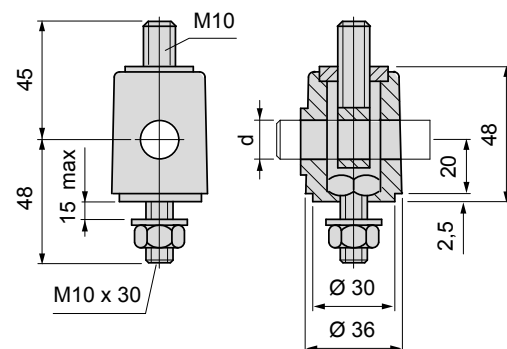

Material	Pin dia. d mm	Code	Weight kg
Reinforced polyamide	12	64561	0,12
PA FV (black)	14	64571	
	16	64581	

- Material: tightening nut and eyebolt in austenitic stainless steel.
- Packaging: 12 pieces.

Part. **S0256**



Part. **S0192**



■ Swivel head

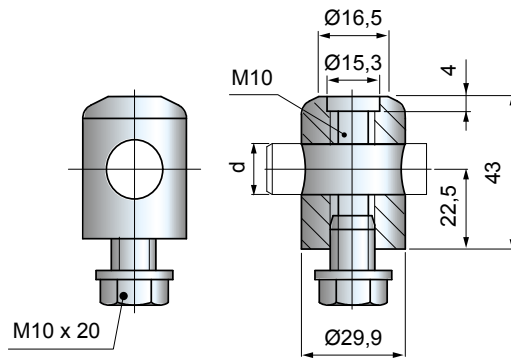

Pin dia. d mm	Materiale	Code	Weight kg
12 (1/2")	Austenitic stainless steel	608683	0,19
14÷16*	Austenitic stainless steel	53091	

* = the bearing head can be used with dia.14 and dia.16 mm pins.
 - Material: tightening bolt in austenitic stainless steel.
 - Packaging: 50 pieces.

■ Swivel head with positioner

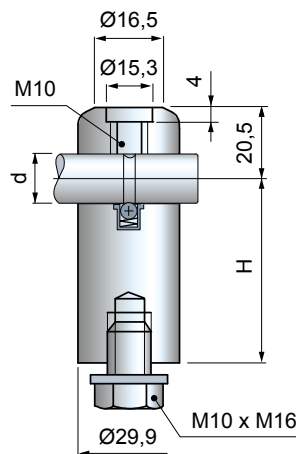

Pin dia. d mm	H mm	Code		Weight kg
		Sans positionneur	Avec positionneur	
14÷16*	40	674012	673962	0,29
	60	674022	673972	

* = Version with positioner can be used only with dia.16 mm pins.
 - Material: swivel head in austenitic stainless steel.
 Tightening bolt in austenitic stainless steel.
 - Packaging: 10 pieces.

• **Assembly** of Part. S0192
 Applicable to brackets Part. S0632 - S0648 - S0540
 (in combination with knob Part. S0185).

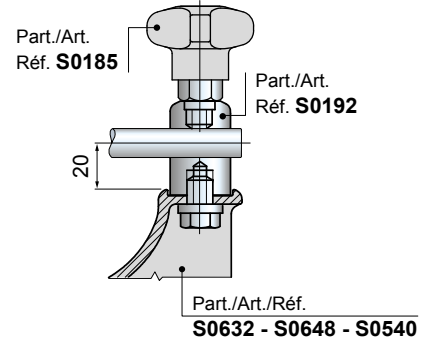

• Use of Part. S0192

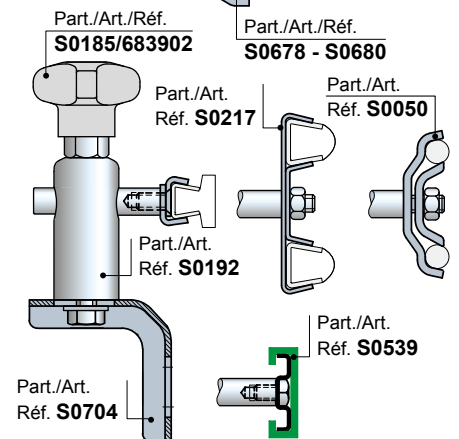
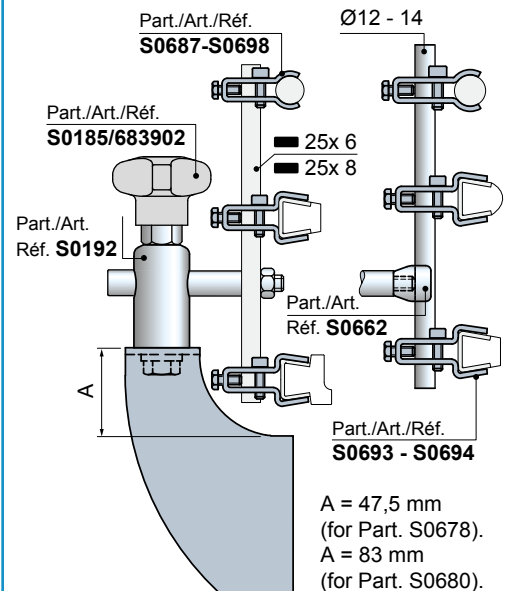

• Pin dimension for positioner

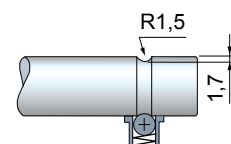

■ Eyebolt

Part. **S0000**

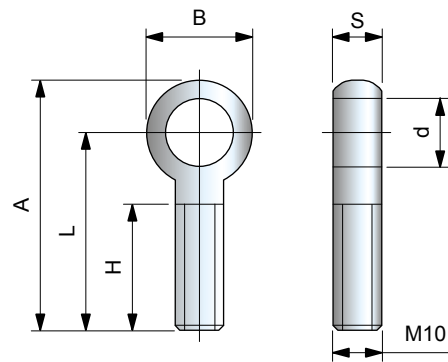

d mm	L mm	H mm	A mm	B mm	S mm	Code
13	30	18	41	20	10	65624
14,2	30	20	41	20	10	61005
20,5	36	22	50	27	7,3	675902

- Material: austenitic stainless steel.
- Packaging: 50 pieces.

Part. S0061

■ **Spacer**

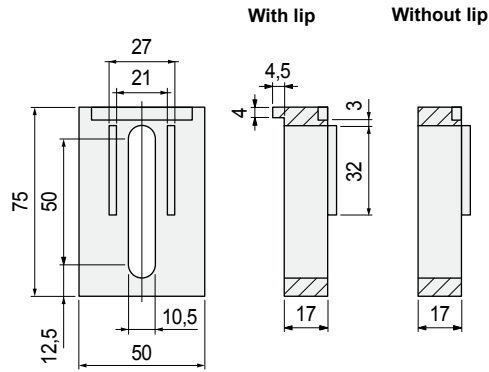

Version	Code	Weight kg
With lip	66194N	0,04
Without lip	50870N	

- Material: reinforced polyamide PA FV (black).
- Packaging: 24 pieces.

• **Assembly** of Part. S0061

Applicable to Part. S0010 - S0097 - S0107 - S0648 - S0650 - S0651 - S0652 - S0653.

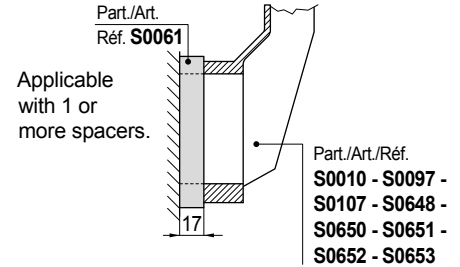

Advantages of version with lip:

Possibility of resting on side of conveyor frame.

Possibility of assembling several spacers, all centred.

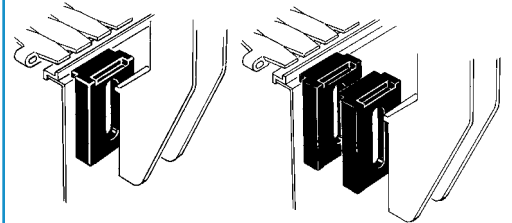

• **Assembly of drip tray support**

Part. S0226 - S0336.
Part. S0061 - S0142
permit application of drip tray support.

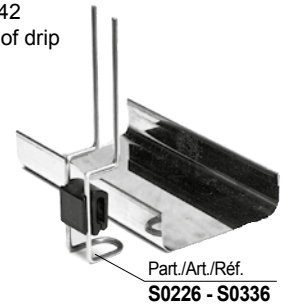

- **Assembly of Part. S0725**
Applicable to Part. S0632 - S0635 - S0636 - S0637 - S0638.

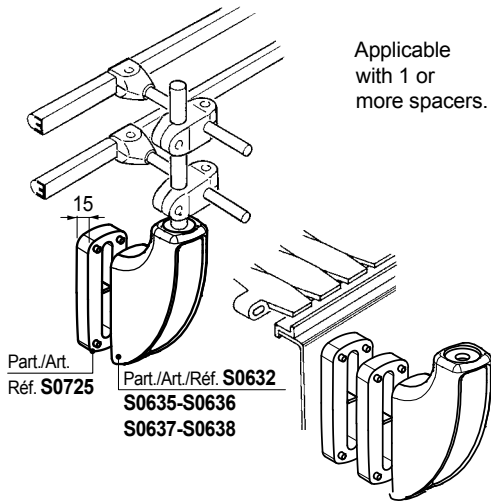

■ Spacer

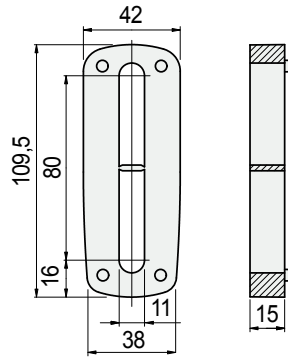

Part. **S0725**



Code	Weight kg
688762	0,05

- Material: reinforced polyamide PA FV (black).
- Packaging: 24 pieces.

- **Assembly of drip tray support**
Part. S0226 - S0336.
Part. S0725 permit application of drip tray support.

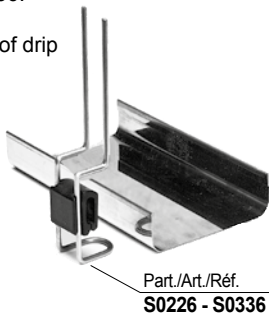

Part. **S0226**

■ Drip tray support



Bent rod

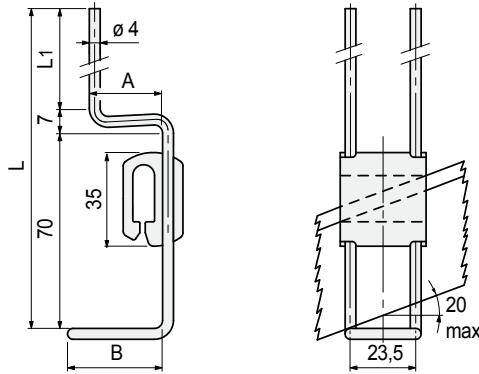

Height L mm	L1 mm	A mm	B mm	Code	
				Part. S0336 Split	Weight kg
180		27	35	60574N	
230	153	27	35	697801N	0,06
310	233	18	35	68299N	

- Material: body in reinforced polypropylene PP FV (black), support element in austenitic stainless steel, self-tapping screw (only for Part. S0336) in stainless steel.
- Packaging: 100 pieces.

• Assembly of Part. S0226 (standard)

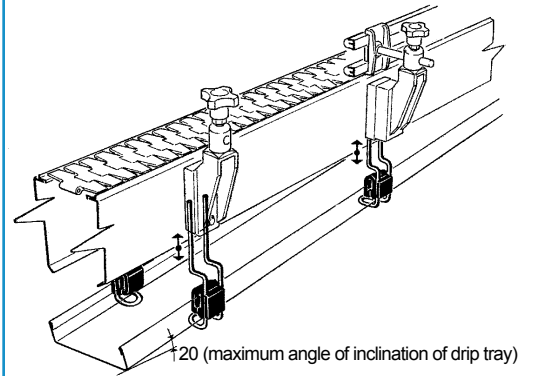

• Drip tray design

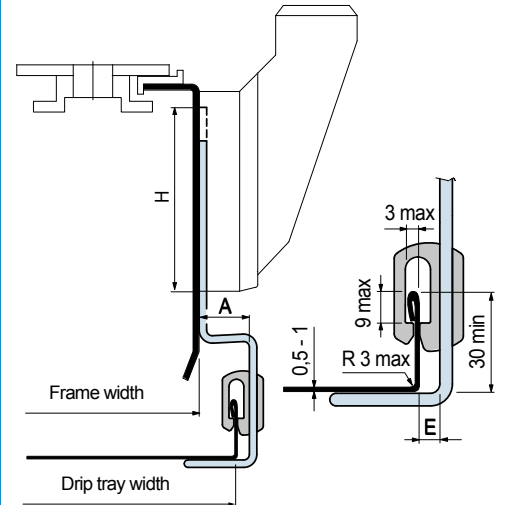

Drip tray width = Frame width + 2 • (A - E)

A = see table with codes

E = 10 mm for Part. S0226 (standard)

Bracket Part.	Rod slot length
	H mm
S0081 - S0088	70
S0072 - S0089	102,5
S0085	53
S0010 - S0097	71
S0107	72
S0599	104
S0140	106
S0617	95
S0632 - S0635 - S0636 - S0637 - S0638	103,5
S0540 - S0541 - S0542 - S0543 - S0544	123

• Assembly of Part. S0336

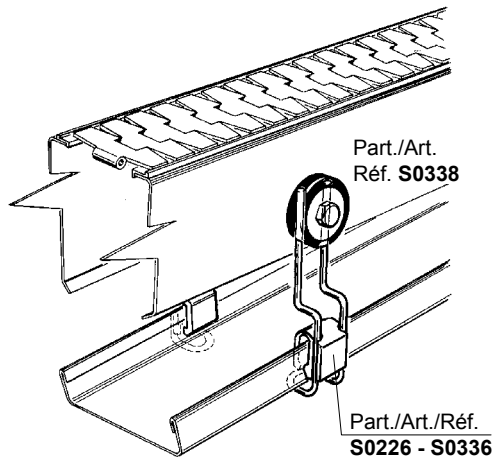

■ Mounting plate

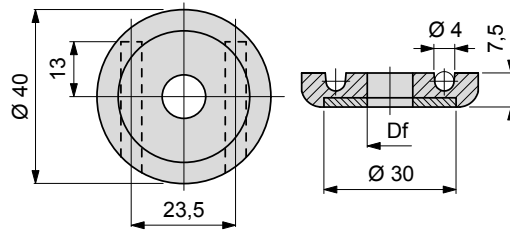

Bore dia. Df mm	Code	Weight kg
9	67563	0,20

- Material: plate in reinforced polyamide (black), washer in austenitic stainless steel.
- Packaging: 100 pieces.

Part. S0338



Part. **S0692**



■ Bracket

Standard version

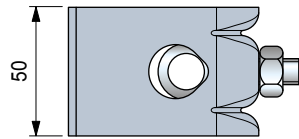
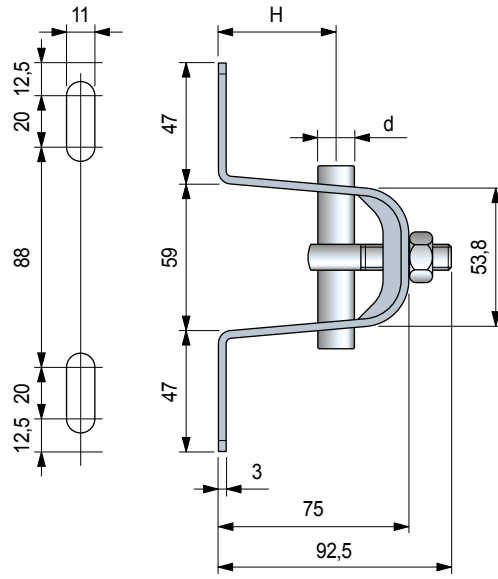

Pin dia. d mm	H mm	Code		Weight kg
		Standard version		
20	42	686302N		0,33

- Material: bracket and bolt in austenitic stainless steel.
- Max recommended tightening torque: 2 Kgm.
- Packaging: 6 pieces.

• Use of Part. S0692

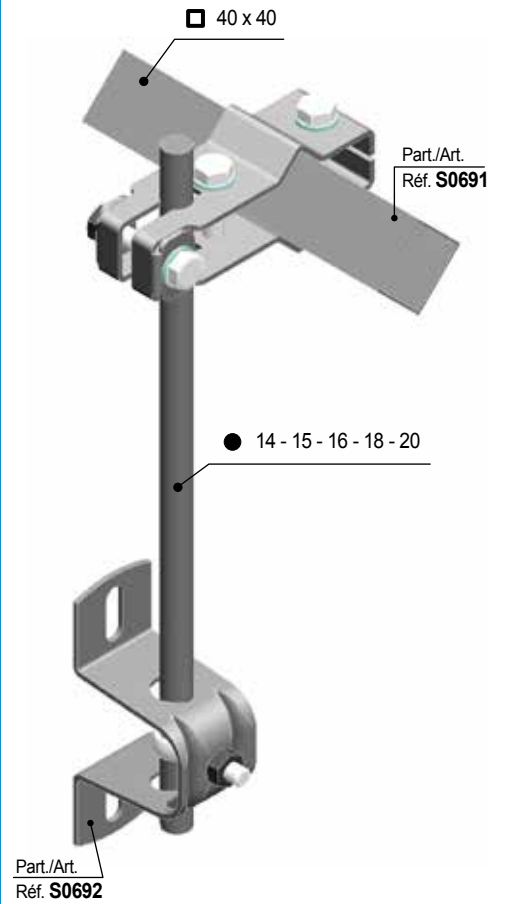

• Use of Part. S0699

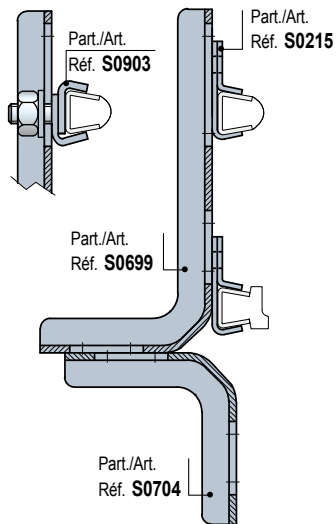
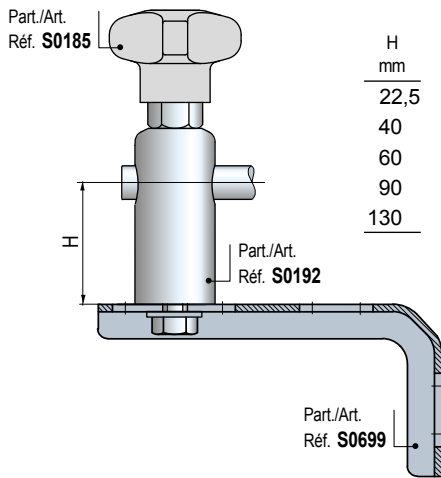

■ Bracket

Part. S0699

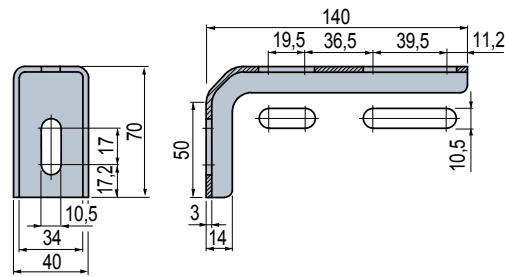

Code	Weight kg
684872	0,23

- Material: austenitic stainless steel.
- Packaging: 6 pieces.

Part. **S0661**



■ Cross clamp

Version without knobs

Version with knobs

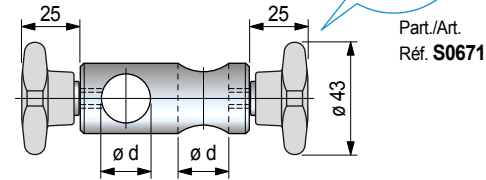

Pin dia.	Code	With knobs	l	A	B	$\varnothing De$
d		knobs	mm	mm	mm	mm
mm						
12	675722		16	40	12	20

- Material: clamp in austenitic stainless steel. Knob in reinforced polypropylene PP FV (grey). Threaded insert in austenitic stainless steel.
- Max recommended tightening torque: 1 Kgm (with knob) 2 Kgm (with screw).
- Packaging: 24 pieces.

• Use of Part. S0661

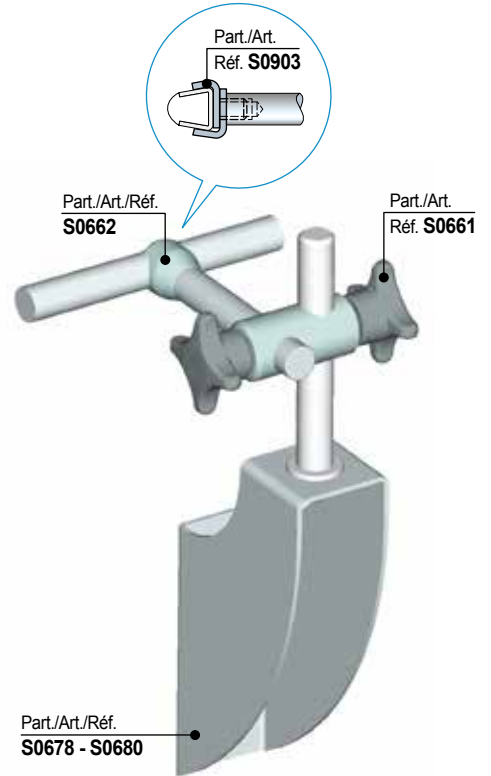

Part. **S0732**



■ Cross clamp with Quick-Set

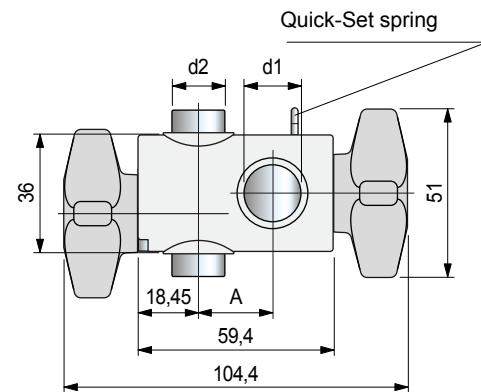

Pin dia. d1 with spring		Pin dia. d2		A	Code	Weight kg
mm	inch	mm	inch			
12	1/2"	12	1/2"	24,1	692352N	0,18
12	1/2"	16	5/8"	24,1	692362N	
16	5/8"	12	1/2"	22	638703N	
16	5/8"	16	5/8"	22	692372N	

- Quick-Set spring on one of the two rods.
- Material: clamp and knobs in reinforced polyamide PA FV (black). Eyebolts in austenitic stainless steel.
- Max recommended tightening torque: 2 Kgm.
- Packaging: 24 pieces.

• Use of Part. S0732

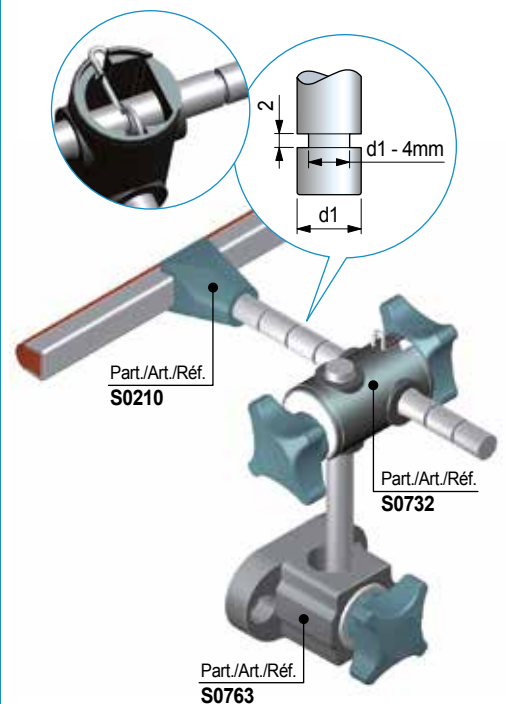

- **T - clamp** Part. S0763
Available with nut or tightening knob.

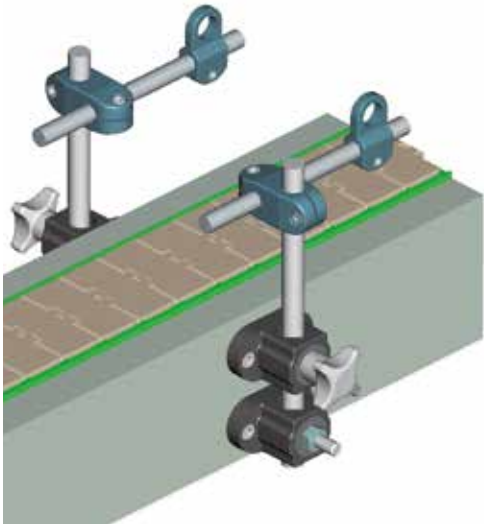

- Can be used in combination with cross clamps Part. S0661 and S0732

Part./Art./Réf. **S0661**



Part./Art./Réf. **S0732**



■ T - clamp with eyebolt

With nut

With knob

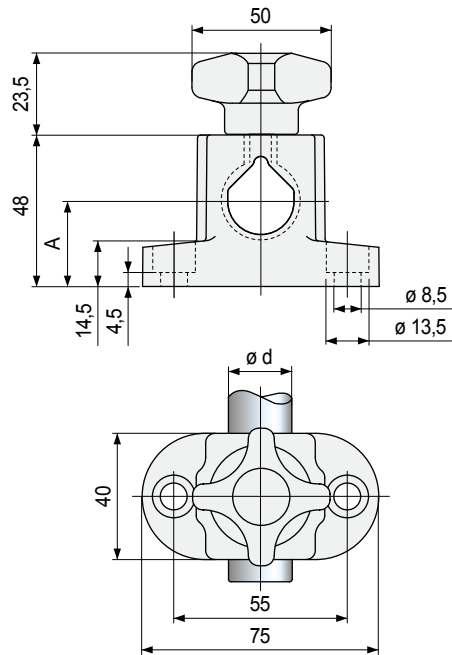

Version	Rod dia.		Code	Weight kg
	d mm	A mm		
with knob	20	27	610633	0,12

- Material: clamp and knob in reinforced polyamide PA FV (black). Threaded insert in nickel plated brass, nut, washer and eyebolt in austenitic stainless steel.
- Max recommended tightening torque: 4 Kgm.
- Packaging: 24 pieces.

Part. **S0340**



■ Cross clamp

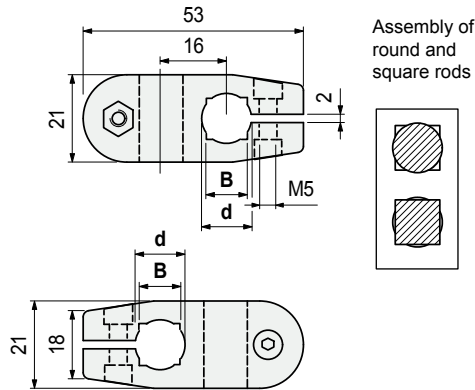

Tightening bolt material	Rod dia. d mm	Square rod B mm	Code	Weight kg
Austenitic stainless steel	10	8	68373	0,02
	12	10	68385	
	14	12	67375	
Zinc plated steel	12	10	627041	

- Material: clamp in reinforced polyamide PA FV (black).
- Max. recommended tightening torque: 0,5 Kgm.
- Packaging: 24 pieces.

Part. **S0174**



■ Cross clamp

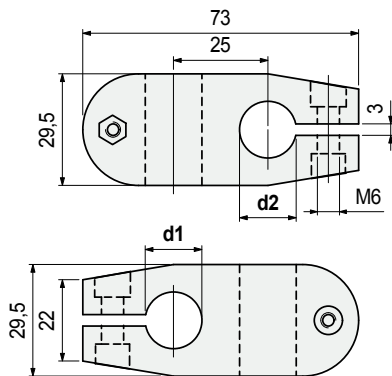

Material	Rod dia. d1 mm	Rod dia. d2 mm	Code	Weight kg
Reinforced polyamide PA FV (black)	14	14	S017457941	0,07
	16	16	S017453781	

- Material: tightening bolt in austenitic stainless steel.
- Max recommended tightening torque: 1 Kgm (Part. S0174); 1,5 Kgm.
- Packaging: 24 pieces.

• Deflection of Part. S0340

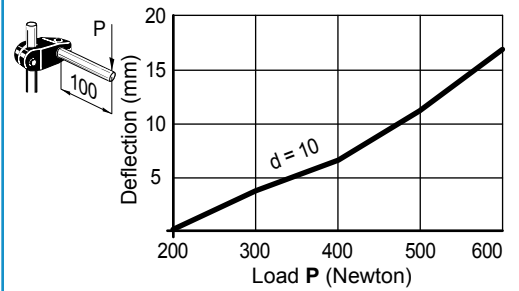

• Technical data Part. S0340

- sliding load: 1200 N
- rotation load: 5 N/m
- Tests performed at tightening torque: 0,5 Kgm

• Deflection of Part. S0174 - S0174R

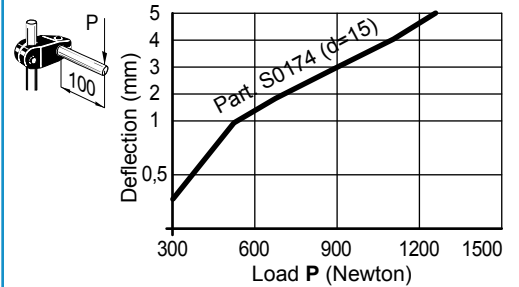

• Technical data Part. S0174

- sliding load: 2500 N (width d = 14 - 15 - 16)
2800 N (width d = 18)
- rotation load: 13 N/m
- Tests performed at tightening torque: 1 Kgm

• Assembly of Part. S0174 with ratchet handle

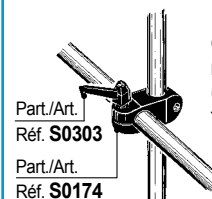

Part./Art. Réf. **S0303**

Part./Art. Réf. **S0174**

Can be applied with the ratchet handle Part. S0303 (code 60922), instead of the standard hardware.

Part. S0339



T-clamp

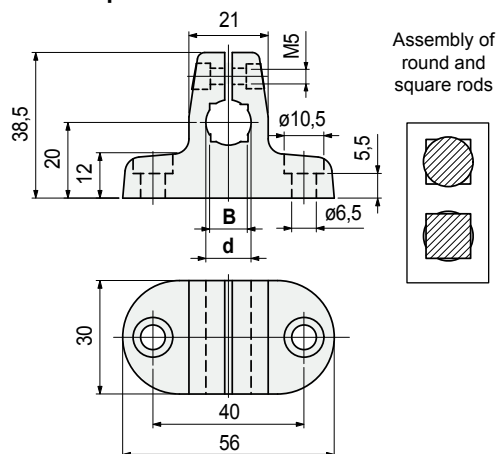

Tightening bolt material	Rod dia. d mm	Square rod B mm	Code	Weight kg
Austenitic stainless steel	10	8	68363	0,03
	12	10	68375	
	14	12	67365	
Zinc plated steel	12	10	627011	

- Material: clamp in reinforced polyamide PA FV (black).
- Max. recommended tightening torque: 0,5 Kgm.
- Packaging: 24 pieces.

Deflection of Part. S0339

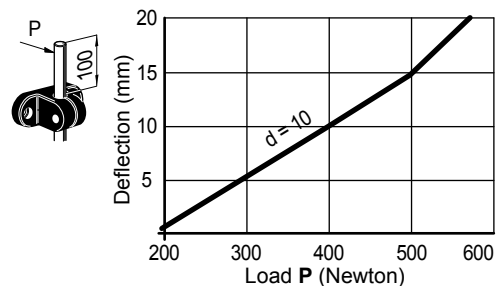

Technical data Part. S0339

- sliding load: 650 N
- rotation load: 5 N/m
- Tests performed at tightening torque: 0,5 Kgm

Assembly of Part. S0339

Can be used in combination with Part. S0340

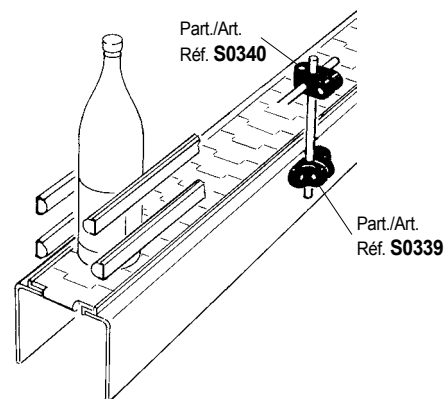

• Characteristics of Part. S0786

Are indicated for end-line applications, to support centre guide or dividers, to separate and align containers before packing area.

• Use of Part. S0786 (for square and round tubes)

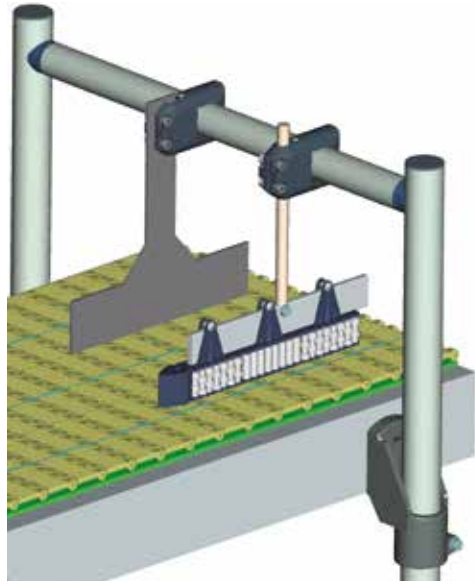
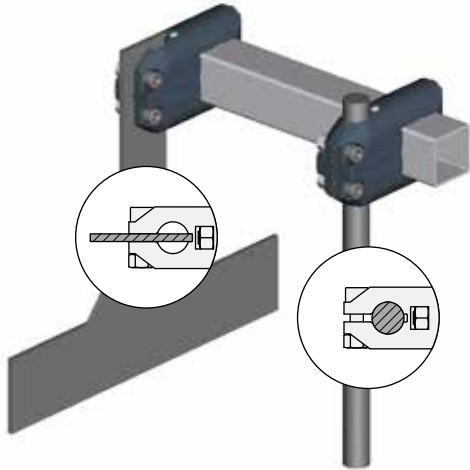

• Use of Part. S0786 (for square and round tubes)



Ratchet handle
spare part code
S0303622433

■ Cross clamp

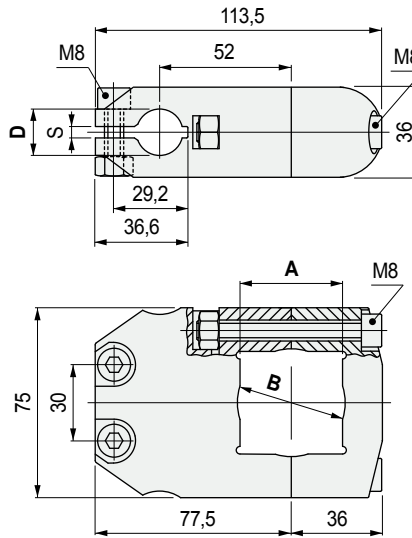

Square tube A mm	Round tube B mm	Round rod D mm	Plate S mm	Code	Weight kg
40	42,4	20	4	621783	0,27

- Material: clamp in reinforced polyamide PA FV (black), tightening screws in austenitic stainless steel, nuts in nickel plated brass.
- Max recommended tightening torque: 2 Kgm.
- Packaging: 8 pieces.

■ Cross clamp

With knob and ratchet handles

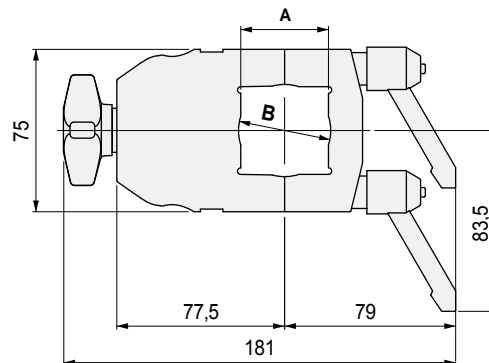

Square tube A mm	Round tube B mm	Rod dia. C mm	d1 mm	Code	Weight kg
40	42,4	52	20	622423	0,30

- Material: clamp in reinforced polyamide PA FV (black), tightening screws in austenitic stainless steel.
- Ratchet handle: handle in reinforced polyamide in PA FV (black), spindle in zinc plated steel.
- Max recommended tightening torque: 2 Kgm.
- Packaging: 8 pieces.

Part. S0786



Part. S0786



Part. S0199



Side mounting top bracket for round

Version with fixing holes for M8

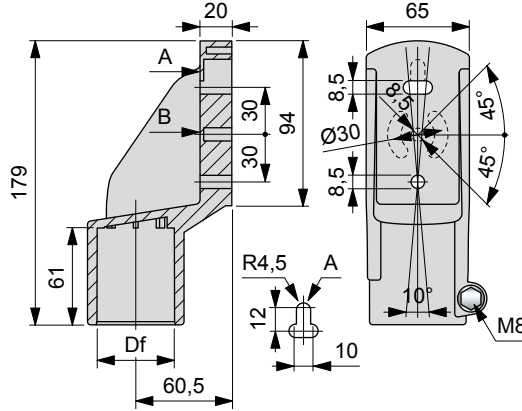

Version with fixing holes for M10

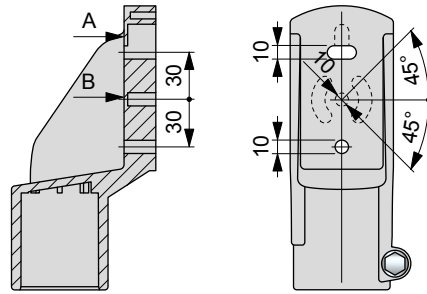

Tube dimensions mm	Bore Df mm	Bolts material	Code
-----------------------	---------------	----------------	------

Version with fixing holes for M8

Ø48,3 (1 1/2) Ø48,3 Austenitic stainless steel 59171N

Assembly of Part. S0199 (with round tubes)

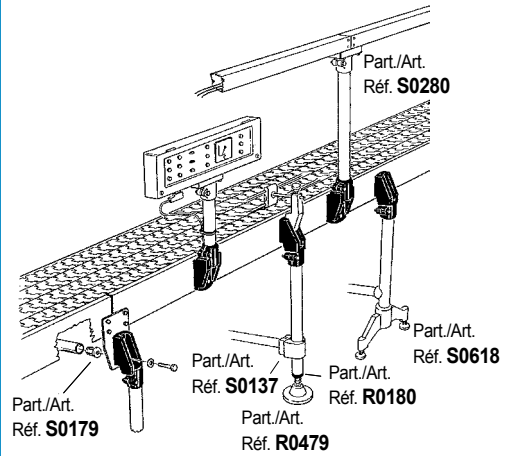

Assembly of Part. S0199 (with square tubes)

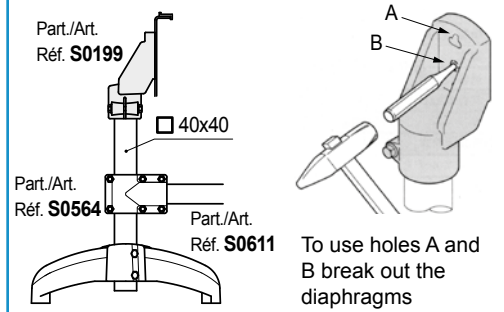

Deflection of Part. S0199

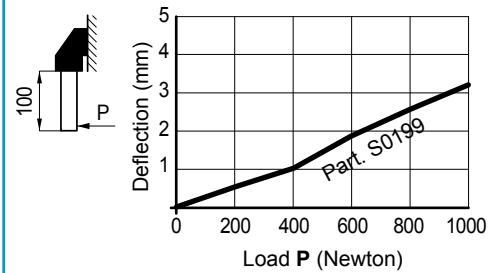

Part. **S0198**

■ Bearing head

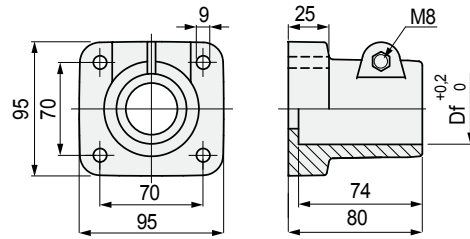

For round and square tubes

Tube dimensions mm	Bore Df mm	Bolts material	Code
Ø 48,3 (1 1/2)	Ø 48,3	Austenitic stainless steel	59161

- Material: reinforced polyamide PA FV (black).
- Weight: 0,30 Kg.
- Max recommended tightening torque: 2 Kgm.
- Packaging: 24 pieces.

• Assembly of Part. S0198 (with round tubes)

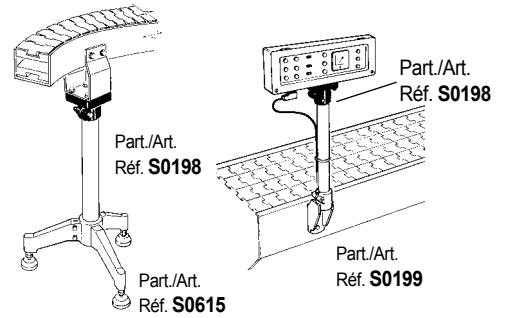

• Assembly of Part. S0198 (with square tubes)

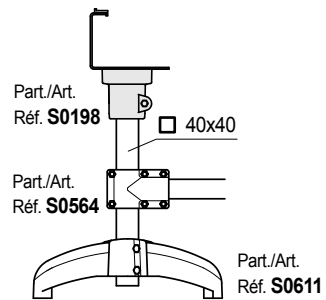

• Deflection of Part. S0198

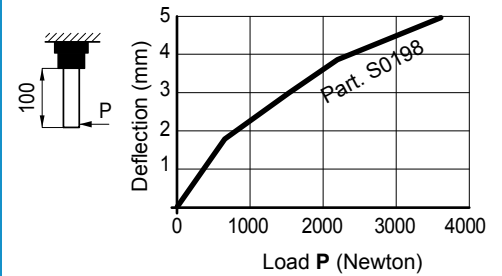

• Sliding load

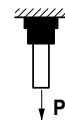

- Part. S0198- Ø48,3 (P = 1900 N)
- Part. S0198- ∅ 38 (P = 4400 N)
- Part. S0198- ∅ 40 (P = 2300 N)

Tests performed at tightening torque: 2 Kgm

• Assembly of Part. S0280

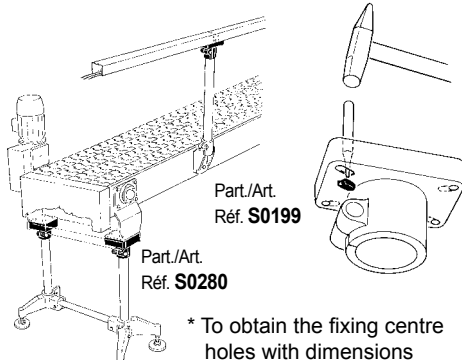

Part./Art.
Réf. **S0199**

Part./Art.
Réf. **S0280**

Part./Art./Réf.
S0616 - S0619

* To obtain the fixing centre holes with dimensions (92 x 55 mm) break out the thickness of diaphragm.

• Deflection of Part. S0280

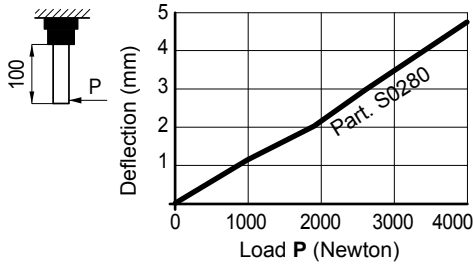

• Sliding load

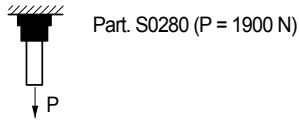

Part. S0280 (P = 1900 N)

Tests performed at tightening torque:
- 3,5 Kgm (for Part. S0280)

■ Bearing head

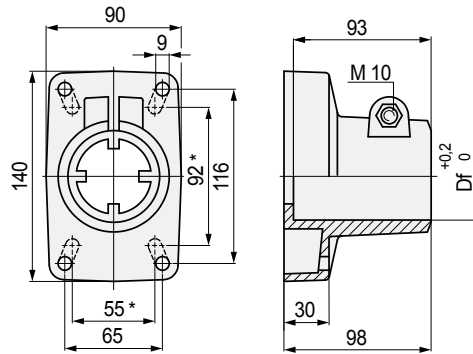

Tube dimensions mm	Bore Df mm	Code
Ø 48,3 (1 1/2")	48,3	63503
Ø 60,3 (2")	60,3	66781

- Material: head in reinforced polyamide PA FV (black).
- Bolts material: austenitic stainless steel.
- Weight: 0,40 Kg.
- Max recommended tightening torque: 3,5 Kgm.
- Packaging: 8 pieces.

Part. **S0280**



For round tubes

Part. S0615

Support base (tripod)



For round tubes

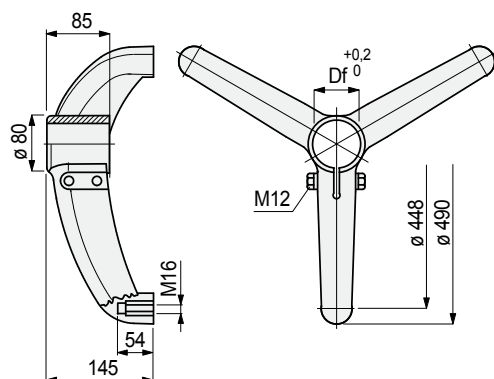

Tube dimensions mm	Bore dia. Df mm	Code
Bolts in austenitic stainless steel		
48,3 (1 7/8")	48,3	624262
50,8	50,8	624272
60,3 (2")	60,3	621522

- Material: support base in reinforced polyamide PA FV (black), brass threaded bushings.
- Weight: 1,45 Kg.
- Max recommended tightening torque: 3,6 Kgm.
- Packaging: 8 pieces.

Assembly of Part. S0615

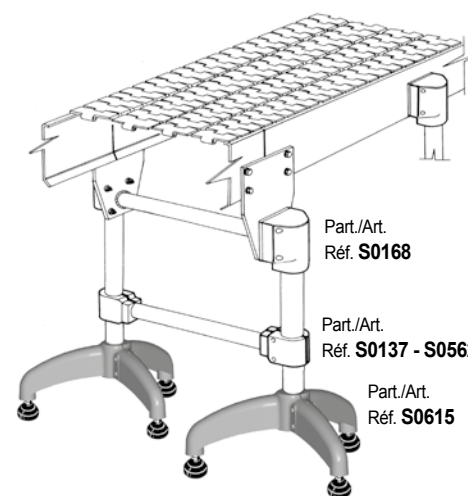
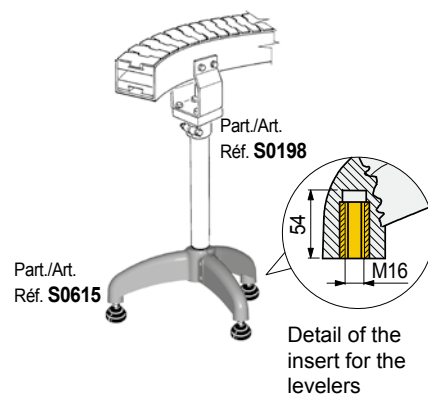

Sliding load

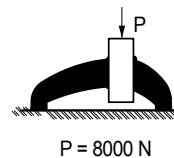

Max applicable load

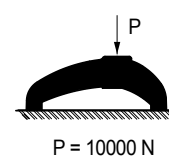

Tests performed at tightening torque: 3,6 Kgm

Types of levelers that can be used

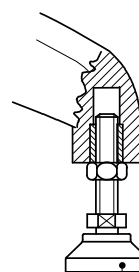

Part./Art./Réf. R0098 - R0133 - R0323

• Assembly of Part. S0618

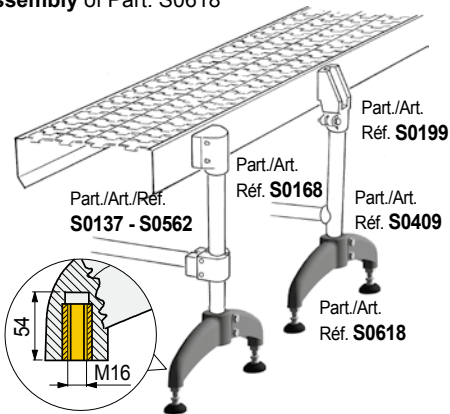

Detail of the insert for the levelers.

• Sliding load

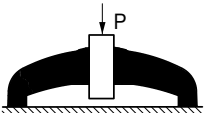

Part. S0618 (P = 8000 N)
Part. S0611 (P = 8000 N)

• Max applicable load

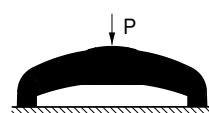

Part. S0618 (P = 9600 N)
Part. S0611 (P = 8000 N)

Tests performed at tightening torque:
3,6 Kgm (Part. S0618), 2,5 Kgm (Part. S0611)

• Types of levelers that can be used

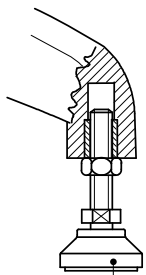

Part./Art./Réf. R0098 - R0133 - R0323

• Assembly of Part. S0611

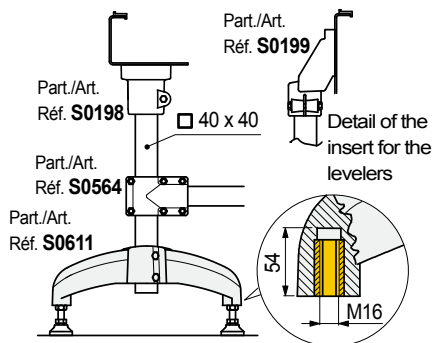

• Part. S0611 available versions

Closed version
Easy to clean

Open version
load

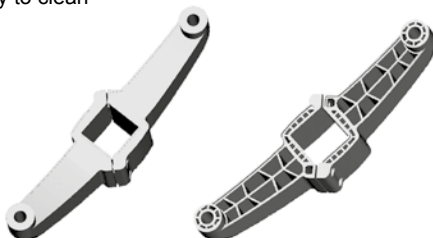

■ Support base (bipod)

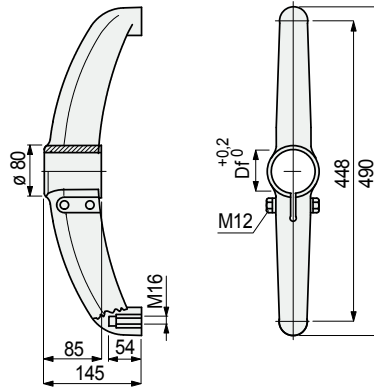

Tube dimensions
mm

Bore dia.
Df
mm

Code

Bolts in austenitic stainless steel

48,3 (1"½)	48,3	624302
50,8	50,8	624312
60,3 (2")	60,3	624322

- Material: support base in reinforced polyamide PA FV (black), brass threaded bushings.
- Weight: 1,05 Kg.
- Max recommended tightening torque: 3,6 Kgm.
- Packaging: 4 pieces.

Part. S0618



For round tubes

■ Support base (bipod)

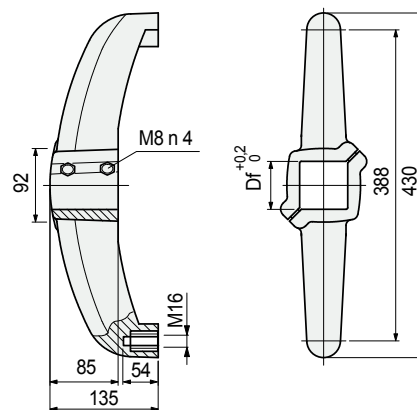

Tube dimensions
mm

Bore
Df
mm

Code

Open
version

∅ 50 x 50	∅ 50	616092
-----------	------	--------

- Material: support base in reinforced polyamide PA FV (black), bolts in austenitic stainless steel, tightening bushes in nickel plated brass, brass threaded bushings.
- Max recommended tightening torque: 2,5 Kgm.
- Weight: 0,9 Kg.
- Packaging: 4 pieces (8 half bases).

Part. S0611



For square tubes

Part. **S0619**

Support base (bipod)



For round tubes

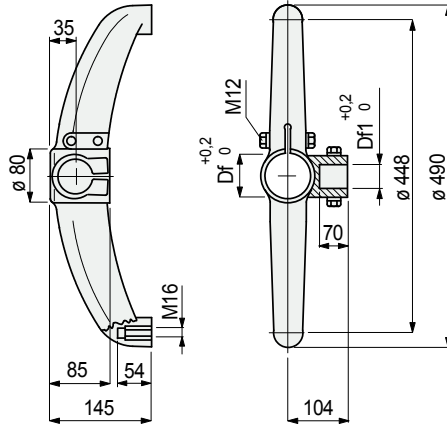

Vertical tube dia. mm	Horizontal tube dia. mm	Bore dia. Df mm	Bore dia. Df1 mm	Code
-----------------------	-------------------------	-----------------	------------------	------

Bolts in austenitic stainless steel

48,3 (1 ⁷ / ₂)	42,4 (1 ³ / ₄)	48,3	42,4	624372
48,3 (1 ⁷ / ₂)	48,3 (1 ⁷ / ₂)	48,3	48,3	692052

Bolts in zinc plated steel

48,3 (1 ⁷ / ₂)	42,4 (1 ³ / ₄)	48,3	42,4	638852
---------------------------------------	---------------------------------------	------	------	--------

- Material: support base in reinforced polyamide PA FV (black), brass threaded bushings.
- Weight: 1,05 Kg.
- Max recommended tightening torque: 3,6 Kgm.
- Packaging: 4 pieces.

• Assembly of Part. S0619

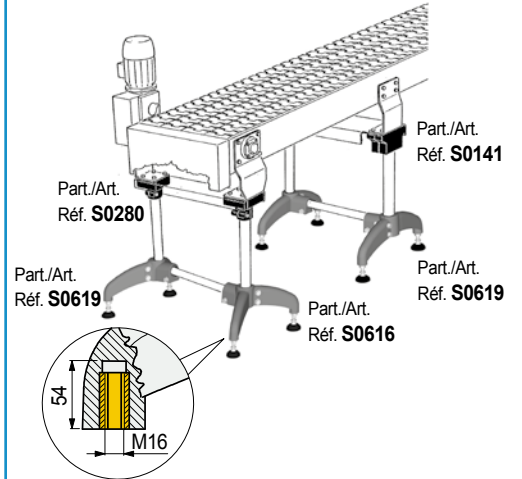

Detail of the insert for the levelers.

• Sliding load

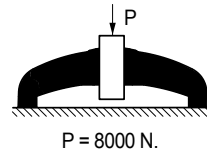

• Max applicable load

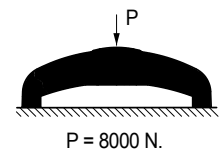

• Deflection

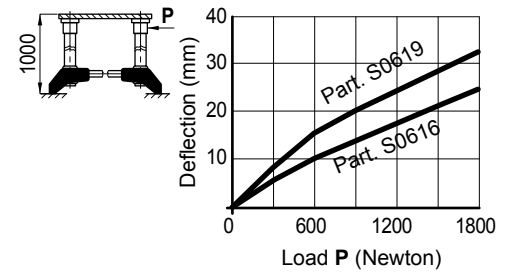

Tests performed at tightening torque: 3,6 Kgm

• Types of levelers that can be used

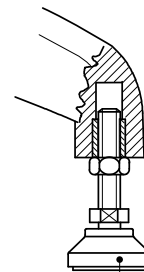

Part./Art./Réf. **R0098 - R0133 - R0323**

• Assembly of Part. S0618

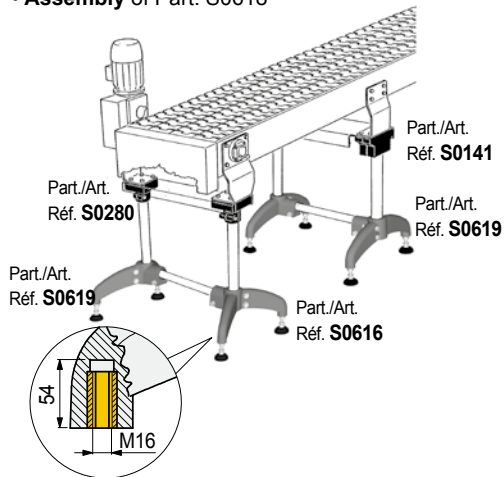

Detail of the insert for the levelers.

• Sliding load

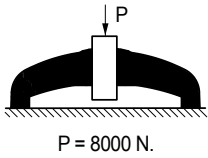

• Max applicable load

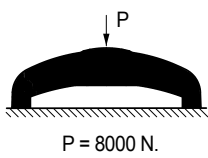

• Deflection

Part. S0616 offers a better rigidity than Part. S0619

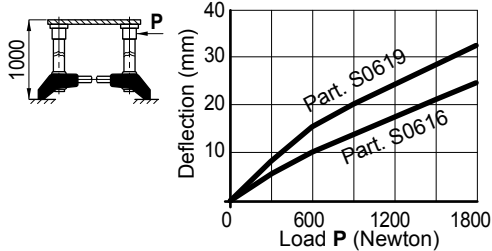

Tests performed at tightening torque: 3,6 Kgm

• Types of levelers that can be used

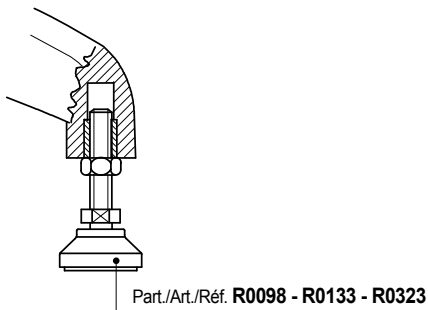

■ Support base (bipod)

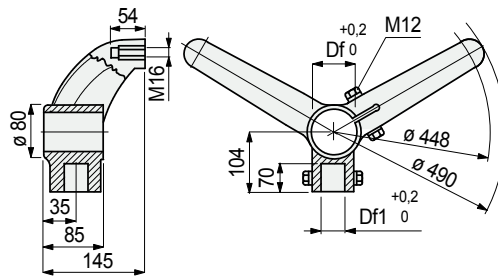

Vertical tube dia. mm	Horizontal tube dia. mm	Bore dia. Df mm	Bore dia. Df1 mm	Code
-----------------------	-------------------------	-----------------	------------------	------

Bolts in austenitic stainless steel

48,3 (1 ⁷ / ₈)	42,4 (1 ³ / ₄)	48,3	42,4	624492
48,3 (1 ⁷ / ₈)	48,3 (1 ⁷ / ₈)	48,3	48,3	611203

- Material: support base in reinforced polyamide PA FV (black), brass threaded bushings.
- Weight: 1,05 Kg.
- Max recommended tightening torque: 3,6 Kgm.
- Packaging: 4 pieces.

Part. S0616



For round tubes

Part. **S0562**



For round tubes

■ Connecting Joints

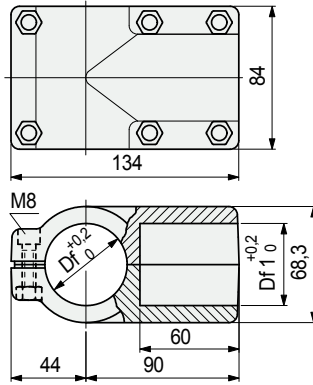

Vertical tube dia. mm	Horizontal tube dia. mm	Bore dia. Df mm	Bore dia. Df1 mm	Code
-----------------------	-------------------------	-----------------	------------------	------

48,3 (1 7/8")	48,3 (1 7/8")	48,3	48,3	697861
---------------	---------------	------	------	--------

- Material: joint in reinforced polyamide PA FV (black). Tightening screws in austenitic stainless steel, nuts in nickel plated brass.
- Weight: 0,4 Kg.
- Max recommended tightening torque: 1,5 Kgm.
- Packaging: 8 pieces.

Part. **S0563**



For round tubes

■ Connecting Joints

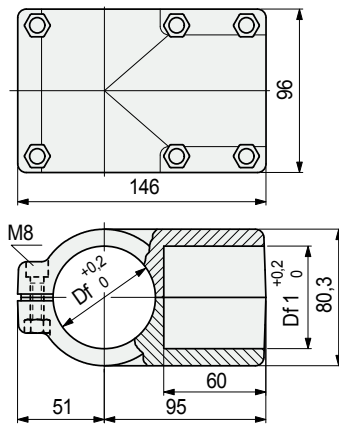

Vertical tube dia. mm	Horizontal tube dia. mm	Bore dia. Df mm	Bore dia. Df1 mm	Code
-----------------------	-------------------------	-----------------	------------------	------

50,8	50,8	50,8	50,8	669512
60,3 (2")	60,3 (2")	60,3	60,3	697891

- Material: joint in reinforced polyamide PA FV (black). Tightening screws in austenitic stainless steel, nuts in nickel plated brass.
- Weight: 0,5 Kg.
- Max recommended tightening torque: 1,5 Kgm.
- Packaging: 8 pieces.

• Assembly of Part. S0562

Example of assembly with vertical tubes \varnothing 33,7 mm

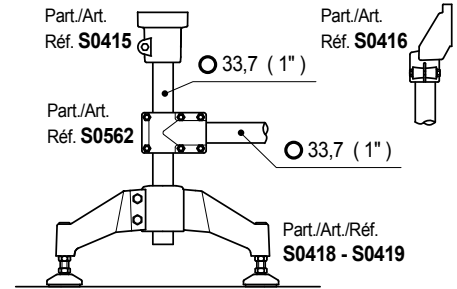

Example of assembly with vertical tubes \varnothing 48,3 mm

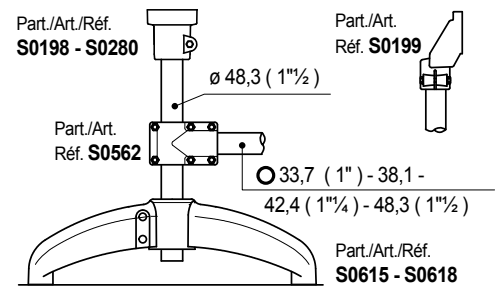

• Assembly of Part. S0563

Example of assembly with vertical tubes \varnothing 60,3 mm

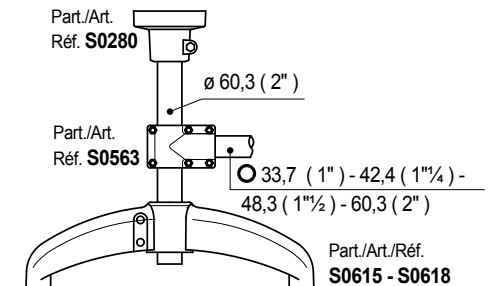

• Sliding load resistance

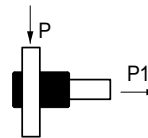

Part. S0562 (P = 2000 N) - (P1 = 3500 N)
Part. S0563 (P = 1500 N) - (P1 = 3000 N)

Tests performed at tightening torque: 1,5 Kgm

• Assembly of Part. S0564

Example of assembly with vertical tubes $\nabla 40$ mm

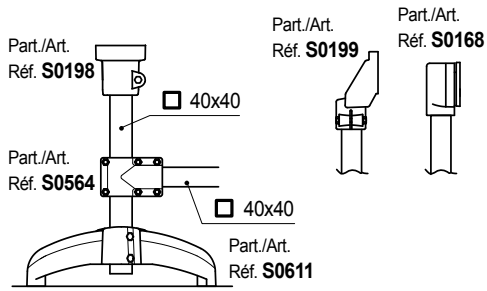

■ Connecting Joints

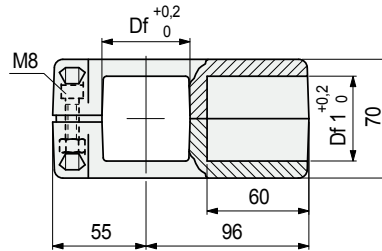
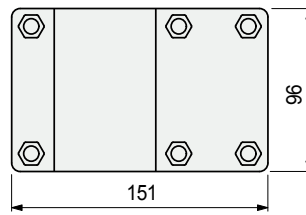

Tube dimensions mm	Bore Df mm	Bore Df1 mm	Code
$\nabla 40 \times 40$	$\nabla 40$	$\nabla 40$	698541
$\nabla 50 \times 50$	$\nabla 50$	$\nabla 50$	698551

Part. S0564



For square tubes

- Material: joint in reinforced polyamide PA FV (black).
Tightening screws in austenitic stainless steel,
nuts in nickel plated brass.
- Weight: 0,5 Kg.
- Max recommended tightening torque: 1,5 Kgm.
- Packaging: 8 pieces.

Part. S0137

■ Connecting Joints



For round tubes

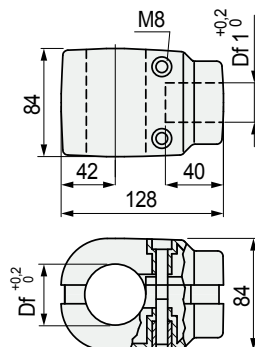

Vertical tube dia. mm	Horizontal tube dia. mm	Bore dia. Df mm	Bore dia. Df1 mm	Code
Ø 48,3 (1 1/2")	Ø 42,4 (1 1/4")	48,3	42,4	66813
Ø 60,3 (2")	Ø 42,4 (1 1/4")	60,3	42,4	65020

- Material: joint in reinforced polyamide PA FV (black). Tightening screws in austenitic stainless steel, tightening bushes in nickel plated brass.
- Weight: 0,44 Kg.
- Max recommended tightening torque: 1 Kgm.
- Packaging: 8 pieces.

• Assembly of Part. S0137

Example of assembly with vertical tubes ø 48,3 mm

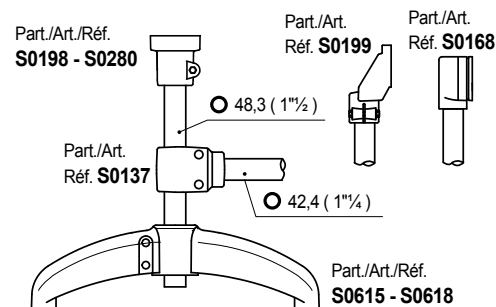

Example of assembly with vertical tubes ø 60,3 mm

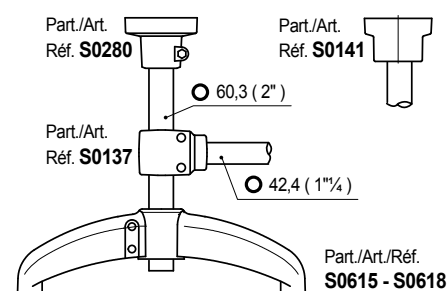

• Deflection

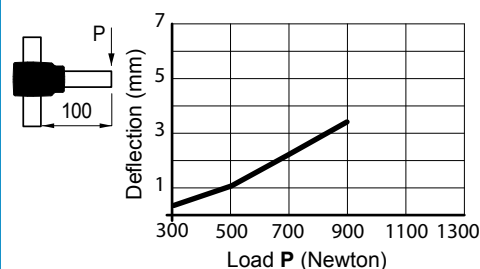

• Sliding load resistance



Tests performed at tightening torque: 1 Kgm

Part. **S0686**



For tubes $\varnothing 48,3$ mm

■ Connecting Joints

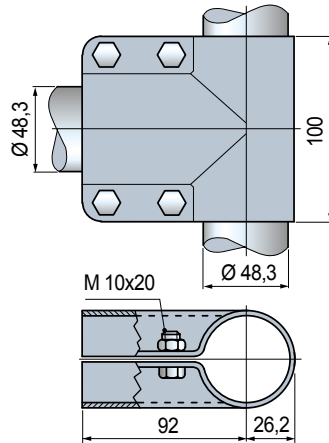

Tube dia. mm	State of supply	Code	Weight kg
48,3 (1"1/2)	With bolts	684512	0,64
	Without bolts	684522	

- Material: joint and bolts in austenitic stainless steel.
- Packaging: 4 pieces.

• Assembly Part. S0686

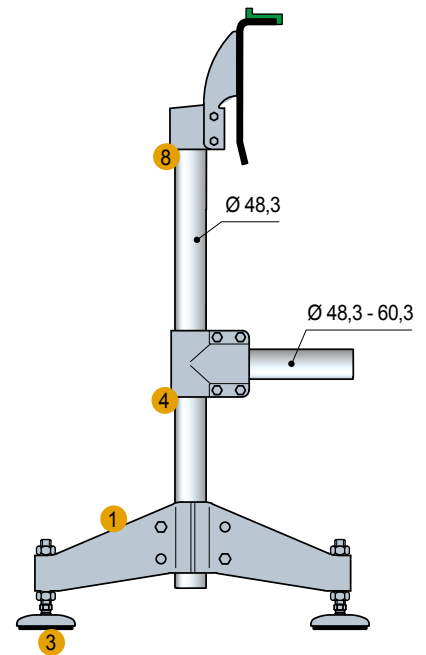
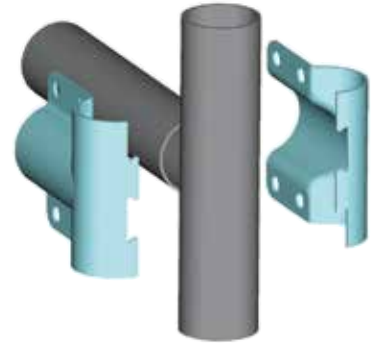

- 1 - Part. S0706
- 2 - Part. S0707
- 3 - Part. S0623 - S0627
- 4 - Part. S0686
- 7 - Part. S0690
- 8 - Part. S0685

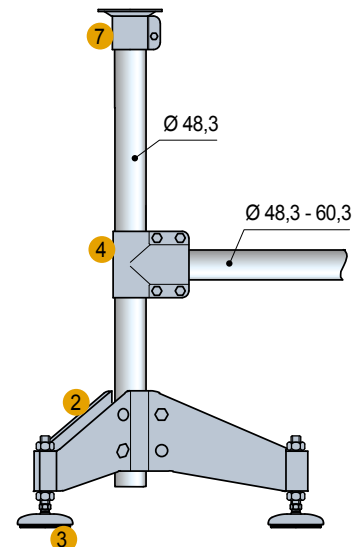

Part. **S0342**

■ Assembly kit for photocells or sensors

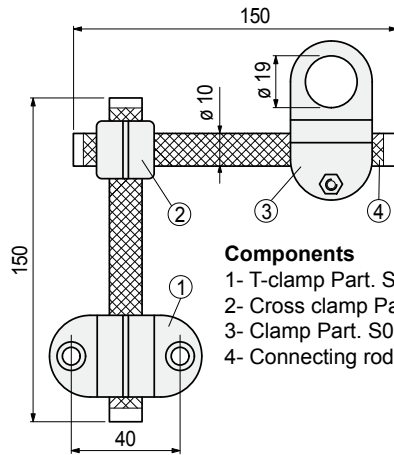

- Components**
 1- T-clamp Part. S0339
 2- Cross clamp Part. S0340
 3- Clamp Part. S0341
 4- Connecting rod

Code	Weight kg
605153N	0,14

- Material: clamps in reinforced polyamide PA FV (black), tightening bolt and connecting rods in austenitic stainless steel.
- Max recommended tightening torque : 0,5 Kgm.
- Packaging: 24 Kit.

Part. **S0341**

■ Clamp for photocells or sensors

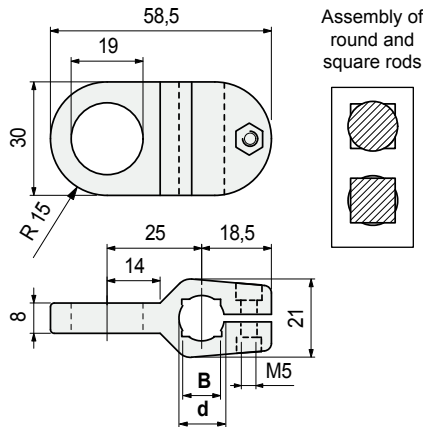

Tightening bolt material	Rod dia. d mm	Square rod B mm	Code	Weight kg
Austenitic stainless steel	12	10	68395	0,02

- Material: clamp in reinforced polyamide PA FV (black).
- Max recommended tightening torque: 0,5 Kgm.
- Packaging: 24 pieces.

• Assembly Part. S0342

Dia. 18 mm photocells or sensors

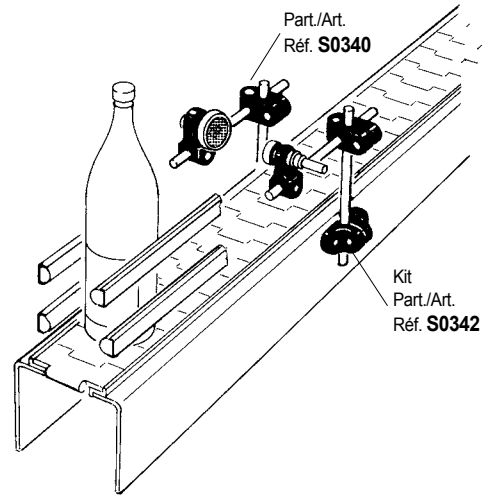

• Assembly Part. S0341

Dia. 18 mm photocells or sensors

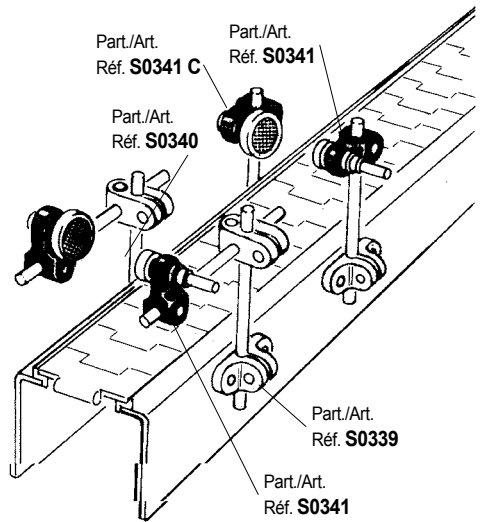

Part. **S0372**



■ Universal clamp for photocells or reflectors

- Can be fitted in positions A - B - C

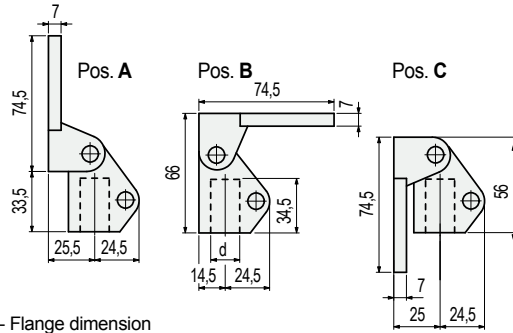

- Flange dimension

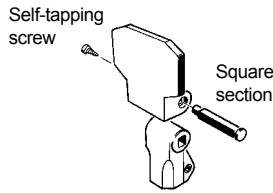
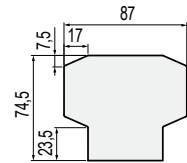

Rod dia. d mm	Code	Weight kg
14	61786	0,12
16	61806	

- Material: clamp in reinforced polyamide PA FV (black), tightening bolt in austenitic stainless steel.
- State of supply: already assembled in position A
- Max recommended tightening torque: 1,5 Kgm.
- Packaging: 24 pieces.

• Assembly Part. S0372

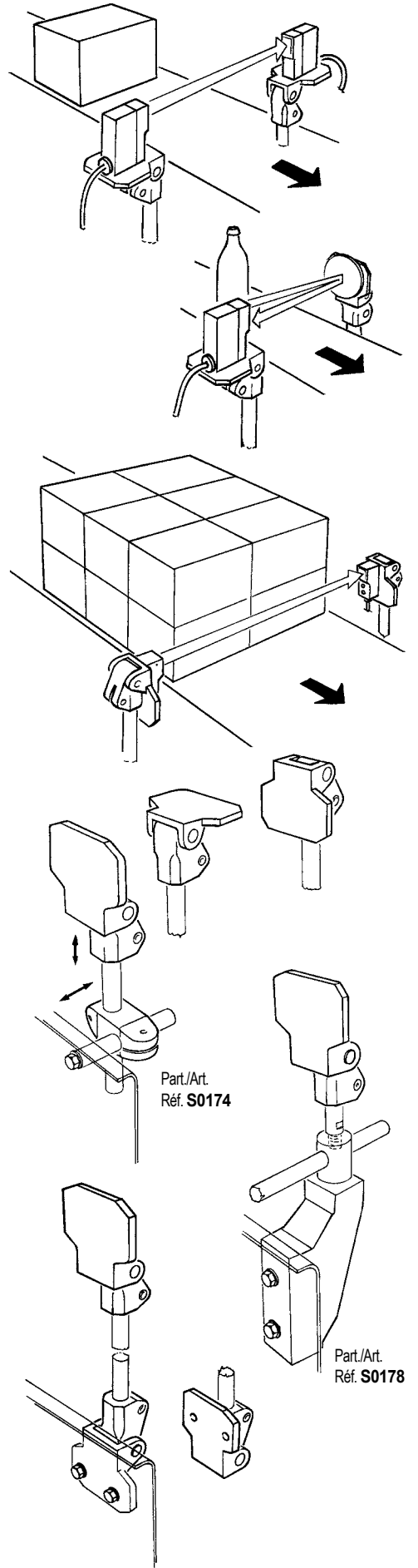

• Suitable photocell types

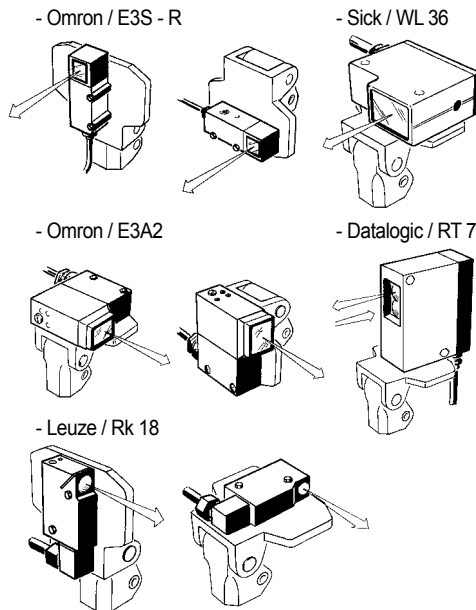

• Suitable reflector types

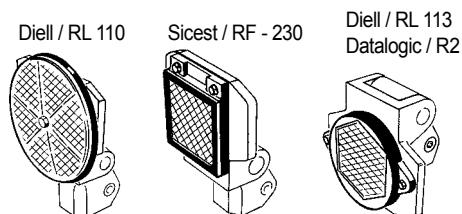

Part. S0518

• Use

Contact lever ideal to mechanically check the presence of products. Works in conjunction with photocells or magnetic sensor (proximity sensor).

• Versions

The control contact lever is supplied in three versions according to the type of sensor to be used.

- 1) With hole and metal insert (for magnetic sensor).

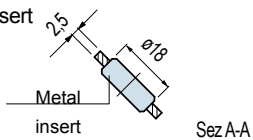

- 2) Without hole

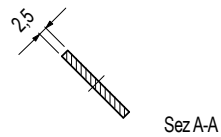

• Assembly on the shaft.

The control contact lever can be axially fixed on the shaft with a metal collar and a grub screw.

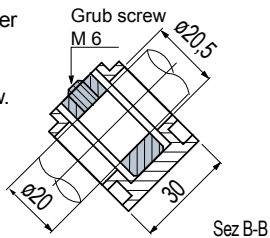

• Assembly of Part. S0518 (with insert for magnetic sensor)

In regular conditions the control contact lever is high and magnetic proximity sensor does not detect the presence of magnetic insert.

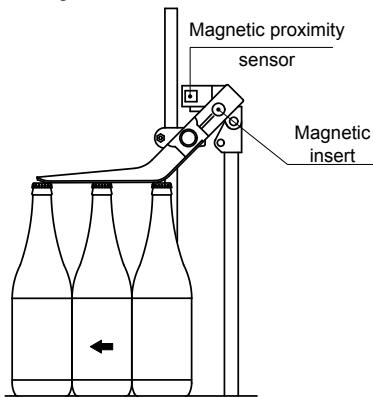

In case of problem (example bottle downing) the control contact lever lowers and magnetic sensor detects the presence of magnetic insert and stops the conveyor.

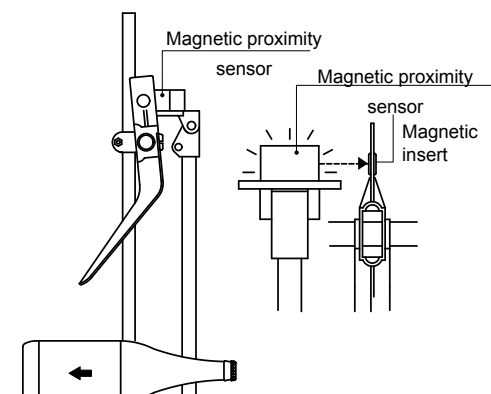

■ Control contact lever

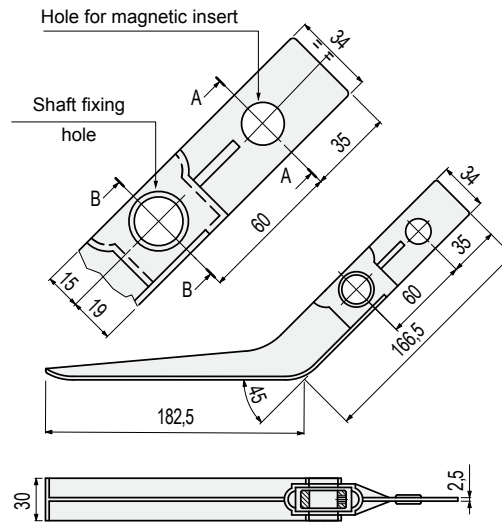

Version	Code	Weight kg
With hole and metal insert	642951N	0,1
Without hole	696021N	

- Material: lever in polypropylene (black), insert (for magnetic sensor) in ferritic stainless steel, locking spacer (for shaft fixing) in zinc plated steel.
- Packaging: 24 pieces.

Part. **S0337**

■ 270° hinge

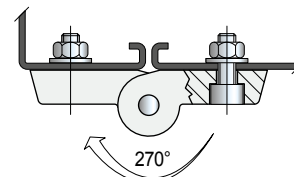
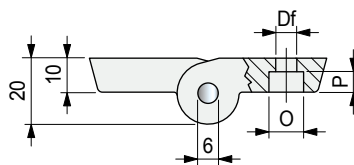
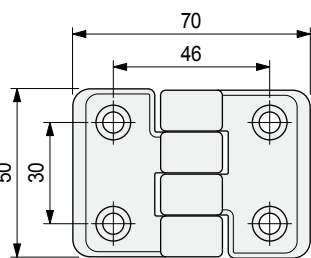

Fixing screws dia.	Code	∅ Df mm	O mm	P mm	Weight gr	Packaging No. of pieces
M 6	67023	6,5	10,5	6	55	24
M 8	60334	8,5	13,5	4		

- Material: hinge in reinforced polyamide PA FV (black). Pin in ferritic stainless steel.
- Max recommended tightening torque: 0,5 Kgm.
- Packaging: 12 pieces

Part. **S0260**

■ 170° hinge

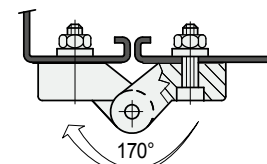
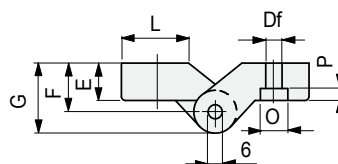
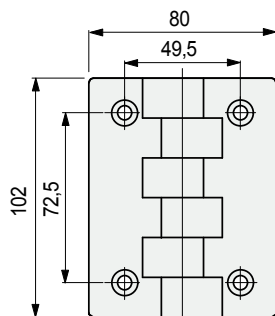

E mm	Fixing screws dia.	Code	∅ Df mm	F mm	G mm	O mm	P mm	L mm	Weight gr	Packaging No. of pieces
11,5	M 6	65021	6,5	14,5	23,5	10,5	6	35	110	20

- Material: hinge in polyamide PA (black). Pin in austenitic stainless steel.
- Max recommended tightening torque: 0,5 Kgm (with M6 screws), 1 Kgm (with M8 screws).
- Packaging: 12 pieces

Part. **S0272**

■ Lock

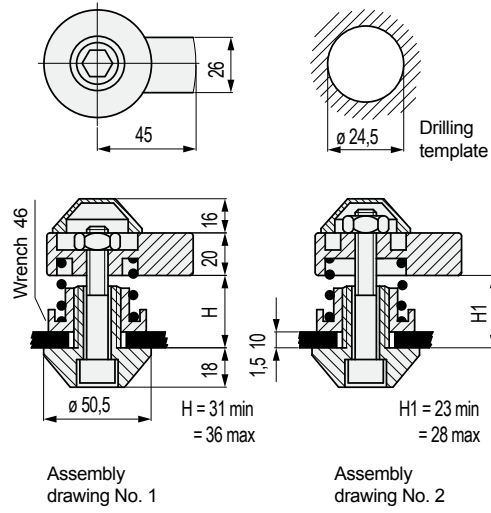

Code	Weight kg
66771	0,2

- Material: body in reinforced polyamide PA FV (black), bolts, nuts and spring in austenitic stainless steel.
- Use: closure of doors in machines for foodindustry (washing, bottling, etc).
- Packaging: 12 pieces.
- Operation with hexagonal bar 10 key.
- Key turn: 360 right or left.
- Assembly instructions:
 Assembly lock as shown in assembly diagram 1, when the size X (Fig. 1) is suitable for assembly distance between 31 ÷ 36 mm. When X (Fig. 1) is between 23 ÷ 28 mm, follow assembly type 2.

• Assembly Part. S0272

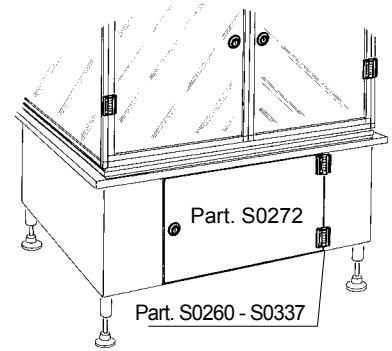

• Fig. 1

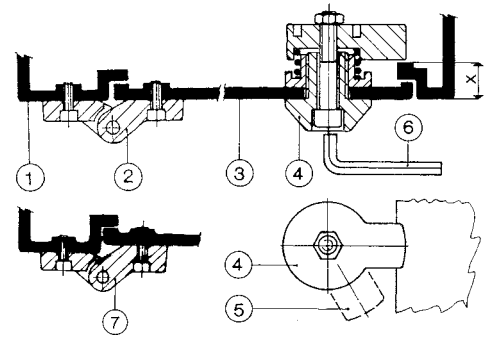

- 1 - Machine structure.
- 2 - Hinge Part. S0260 - S0337.
- 3 - Door.
- 4 - Lock Part. S0272 (in closed position).
- 5 - Lock Part. S0272 (in open position).
- 6 - Lock key (with exagonal 10 wrench).
- 7 - Hinge Part. S0260 (for misaligned mounting surfaces).

Ratchet handle clamping

Part. **S0303**

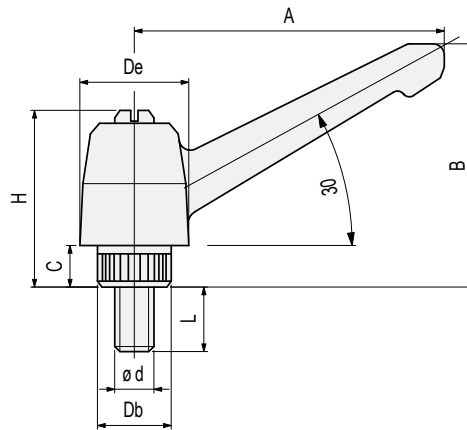

Bore dia. d	A mm	B mm	C mm	L mm	H mm	Db mm	De mm	Code
M8	55	51	10	25	37	15	20	60872

- Material: handle in reinforced polyamide in PA FV (black), spindle in austenitic stainless steel.
- Packaging: 12 pieces.

Part. **S0182**



■ Tightening knob

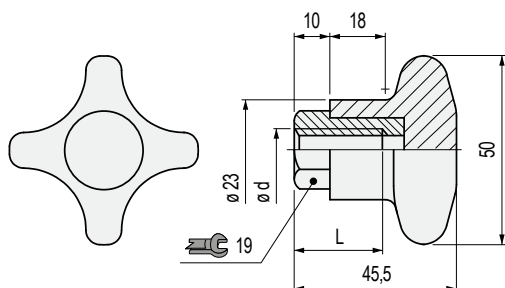

Thread dia. d	Code	L mm
Threaded insert in austenitic stainless steel		
M8	649961N	23
Threaded insert in nickel plated brass		
M10	54911	28

- Material: knob in reinforced polyamide PA FV (black), threaded insert in nickel plated brass.
- Max recommended tightening torque: 2,5 Kgm (manual tightening), 4 Kgm (tightening with wrench). For high tightening torques apply a 19 mm wrench to the hexagon of the insert.
- Packaging: 12 pieces.

Part. **S0183**



■ Tightening knob

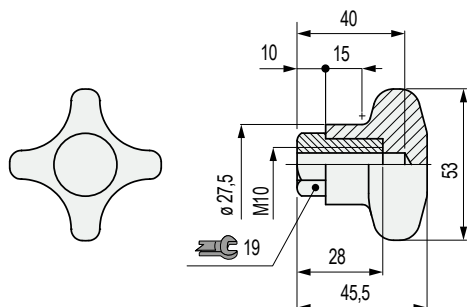

Code
54921

- Material: knob in reinforced polyamide PA FV (black), threaded insert in nickel plated brass.
- Max recommended tightening torque: 2,5 Kgm (manual tightening), 4 Kgm (tightening with wrench). For high tightening torques apply a 19 mm wrench to the hexagon of the insert.
- Packaging: 12 pieces.

■ Tightening knob

Part. **S0185**

Version with hexagonal key

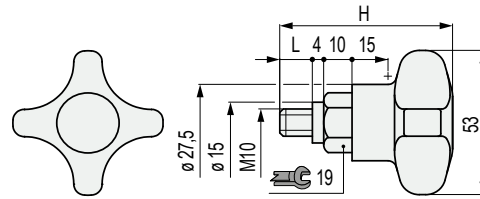

Material knob	L mm	Code	H mm
Version with hexagonal key			
Reinforced Polyamide PA FV (black)	11	53081	61

- Use: version with knob in reinforced Polypropylene PP FV (grey), gives a better resistance to chemical agents.
- Material: knob in reinforced polyamide PA FV (black), (threaded insert in nickel plated brass).
With knob in reinforced Polypropylene PP FV (threaded insert in austenitic stainless steel).
- Max recommended tightening torque: 2,5 Kgm (manual tightening), 4 Kgm (tightening with wrench).
For high tightening torques apply a 19 mm wrench to the hexagon of the insert.
- Packaging: 12 pieces.

Part. S0567



End transfer module (with lip)

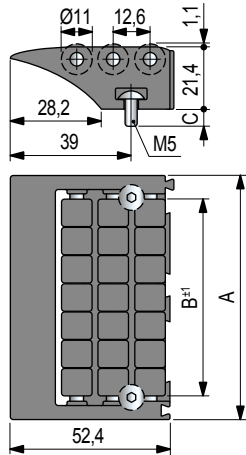

Code

A mm	B mm	C mm	Code
85	67,6	Without screws	688792
		13	688812
115	97	Without screws	687382
		13	677322

- Material: roller pins and screws in austenitic stainless steel.
- Modularity: snap-on assembly with Part. S0568.
- Packaging: 10 pieces.
- Weight: A=85: 0,09, A=115: 0,11.

Part. S0672



End transfer module (with lip)

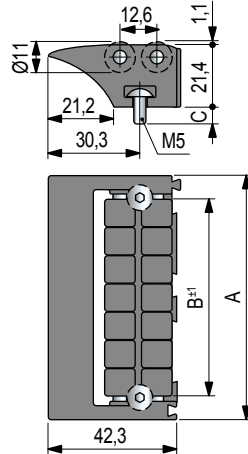

Code

A mm	B mm	C mm	Code
85	67,6	Without screws	687412
115	97	Without screws	687432

- Material: roller pins and screws in austenitic stainless steel.
- Modularity: snap-on assembly with Part. S0568.
- Packaging: 10 pieces.
- Weight: A=85: 0,09, A=115: 0,11.

Fixing

Screws are tightened with an hexagon key inserted between rollers.

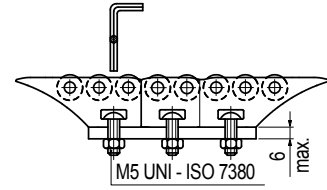

Head to tail transfer of small and light products.

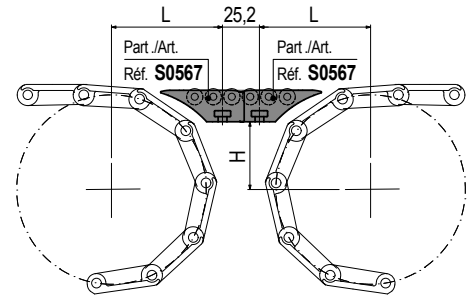

L and H see page S0164.

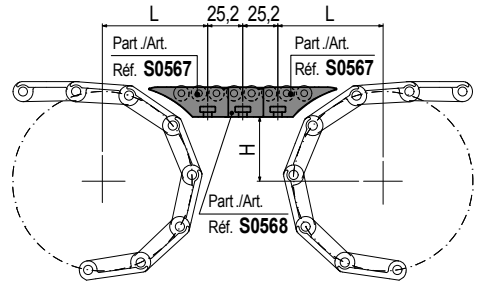

L and H see page S0164.

Compact version.

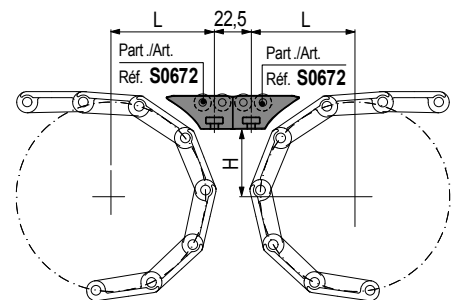

L and H see page S0166.

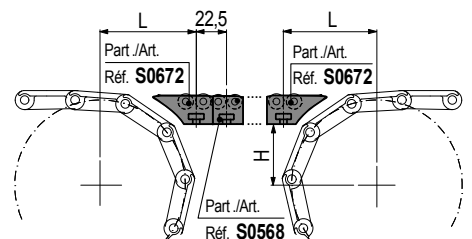

L and H see page S0166.

- Head to tail transfer of big and heavy products.

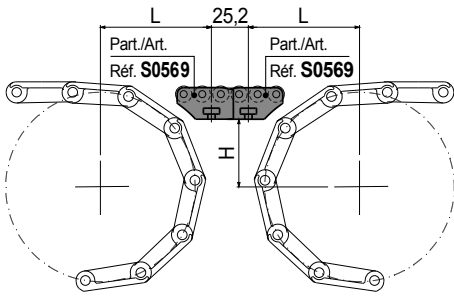

L and H see page S0164.

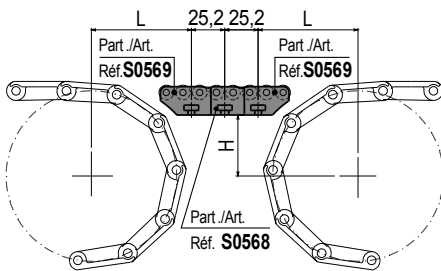

L and H see page S0164.

- 90° transfer of small and light products.

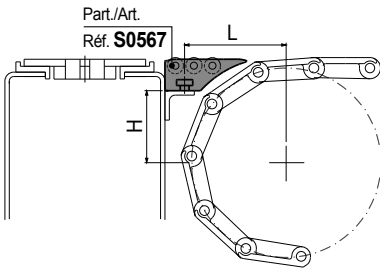

L and H see page S0164.

Compact version.

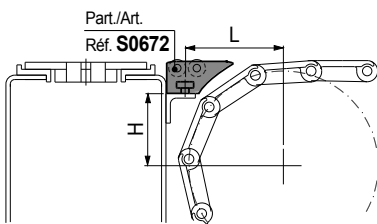

L and H see page S166.

- 90° transfer of big and heavy products.

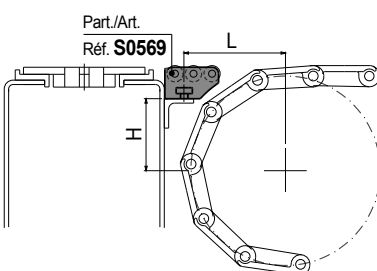

L and H see page S0164.

End transfer module

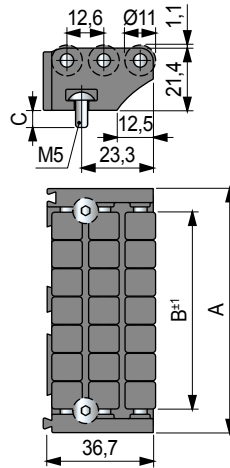

Code

A mm	B mm	C mm	Frame and Rollers in acetal Rex-HP (dark grey)
85	67,6	Without screws	605922
		13	601092
115	97	Without screws	687392

- Material: roller pins and screws in austenitic stainless steel.
- Modularity: snap-on assembly with Part. S0568.
- Packaging: 10 pieces.
- Weight: A=85: 0,09, A=115: 0,10.

Part. S0569



End transfer module

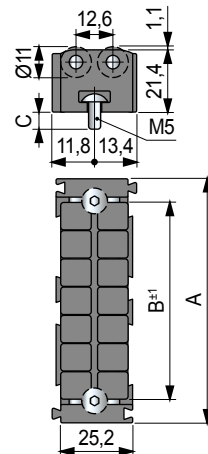

Code

A mm	B mm	C mm	Frame and Rollers in acetal Rex-HP (dark grey)
85	67,6	Without screws	605912
		13	601082
115	97	Without screws	687402

- Material: roller pins and screws in austenitic stainless steel.
- Modularity: snap-on assembly with Part. S0567 - S0569 - S0672.
- Packaging: 20 pieces.
- Weight: A=85: 0,08, A=115: 0,10.

Part. S0568





846 Roller Transfer Plates

Features Rexnord HP™ acetal frame and two rows of Rexnord XLBP rollers for extra low friction.

10604101 ROL-PLT 846 LIP2 L85MM XLBP

10604102 ROL-PLT 846 LIP2 L115MM XLBP



847 Roller Transfer Plates

Features Rexnord HP acetal frame and three rows of Rexnord XLBP rollers for extra low friction.

10604103 ROL-PLT 847 LIP3 L85MM XLBP

10604104 ROL-PLT 847 LIP3 L115MM XLBP



848 Roller Transfer Plates

Features Rexnord HP acetal frame and five rows of Rexnord XLBP rollers for extra low friction.

10604105 ROL-PLT 848 LIP5 L85MM XLBP

10604116 ROL-PLT 848 LIP5 L115MM XLBP



849 Roller Transfer Plates

Features Rexnord HP acetal frame and two rows of Rexnord XLBP rollers for extra low friction.

10604117 ROL-PLT 849 END L85MM XLBP

10604118 ROL-PLT 849 END L115MM XLBP



850-865 Assembly Bar

Reinforced polyamide bar allows for modular assembly of roller transfer plates with widths of 85 millimeter and higher.

Metric code nr. S0850646733

Inch code nr. S0865646743



864 Profile for Compact Transfer Plates

Allows for modular assembly when used in combination with the 850 assembly bar and 846 transfer plates.

Code nr. S0864646663

Part. S0905

■ Dynamic "Nose - Over" bar standard profile

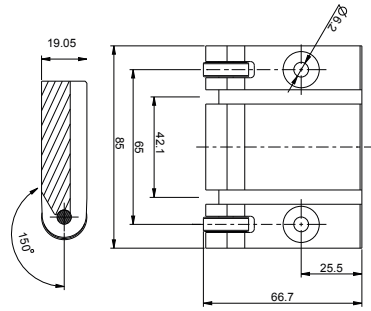
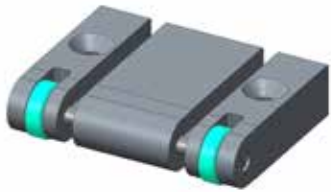

Description	Code	Weight mm
Nose Over Dyn 905 L85MM M6 PT	10603961	0,18

- Material: Polyethylene ULF 500.000 (brown red).
- Packaging: 1 pieces.

• Modular nose - over bar standard

N2 M6 socked flat head cap screws UNI 5933.

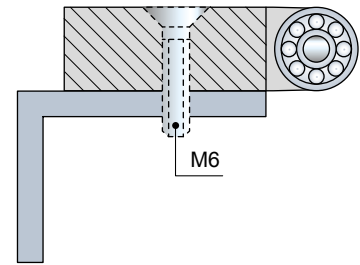

• Assembly of Part. S0905

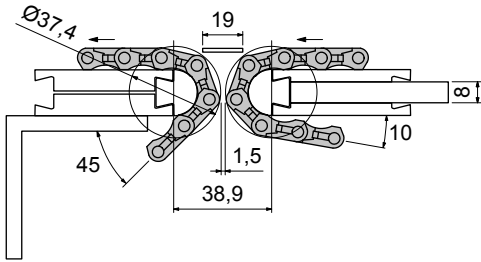

• Assembly of "Nose - Over" bar with 8 mm plate

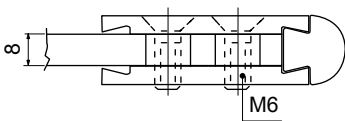

• Assembly of Part. S0905

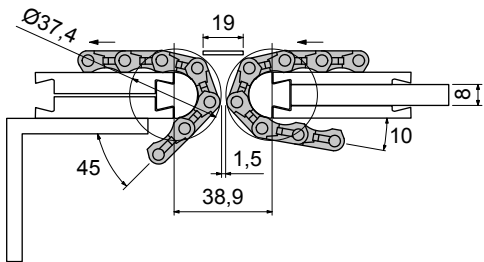

• Modular nose - over bar standard

N4 M8 socked flat head cap screws UNI 5933.

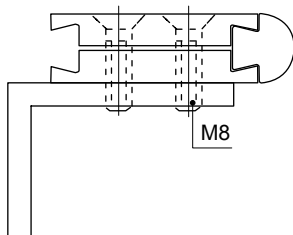

• Use of Part. S0905

Head to tail transfer with MatTop® chain Series 1500.

■ Modular "Nose - Over" bar low profile

Version L = 152,4 e 170

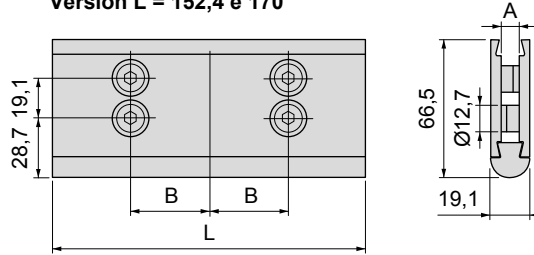

Version L = 255

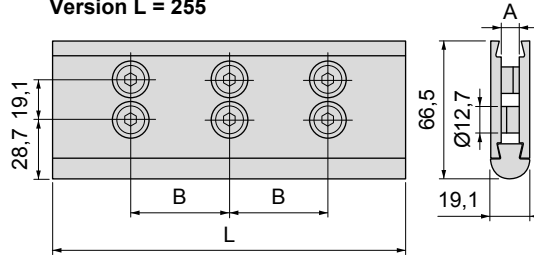

L mm	B mm	Hardware	A	Code	Weight Kg
152,4	38,1	M6	8 mm	10483148	0,18
		1/4-20	0,25 inch	10483150	
170	42,5	M6	8 mm	10476256	0,20
255	85	M6	8 mm	10476257	0,31

- Material: clamp in polyamide PA (black), sliding profile in ULF, steel hardware.
- Packaging: 1 pieces.

Part. S0905



■ Modular "Nose - Over" bar standard profile

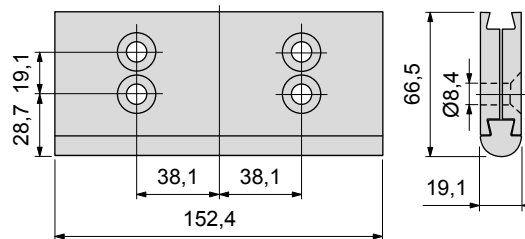

Code	Weight mm
10483148	0,18

- Material: clamp in polyamide PA (black), sliding profile in ULF.
- Packaging: 1 pieces.

Part. S0905



Part. **S0612**

■ Split shaft collar (with round bore)

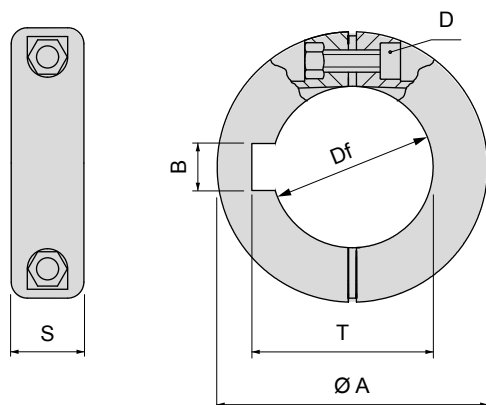

Bore dia.	Ø A	S	B	T	D	Code	Weight
mm	inch	mm	mm	mm	mm		kg
Without seat keyway							
-	1/2"	30	11,7	-	-	M4 655072	-
16	5/8"	35	11,7	-	-	M4 655092	-
-	3/4"	40	14	-	-	M4 655102	-
20	-	40	14	-	-	M4 614722	0,019
25	-	45	14	-	-	M4 619452	0,022
30	-	50	16	-	-	M4 640602	0,026
-	1 1/4"	50	16	-	-	M4 608463	-
-	1 1/2"	63,5	18	-	-	M5 611283	-
40	-	63,5	18	-	-	M5 686232	0,040
With seat keyway							
25	-	45	14	8	28,3	M4 683812	0,022
-	1"	45	14	6,4	28,58	M4 655112	-
30	-	50	16	8	33,3	M4 614732	0,026
-	1 1/4"	50	16	6,4	34,98	M4 655122	-
-	1 7/16"	63,5	18	9,58	41,02	M5 605043	-
-	1 1/2"	63,5	18	9,58	42,65	M5 655132	-
40	-	63,5	18	12	43,3	M5 615012	0,040

- Material: collar in reinforced polyamide PA FV (black), tightening bolt in austenitic stainless steel.
- Max recommended tightening torque: 0,3 Kgm.
- Packaging: 24 pieces.

• Assembly of Part. S0612 (with round bore)

- With sprockets

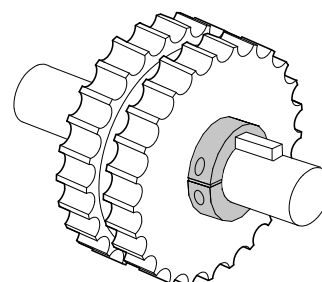

- With idler wheels

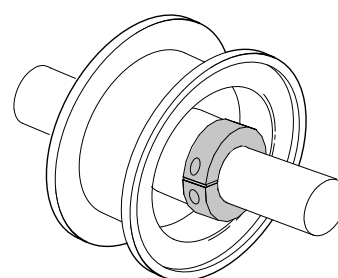

- With rollers

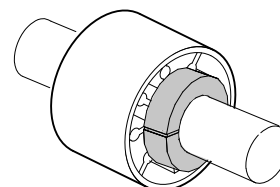

- With side brackets

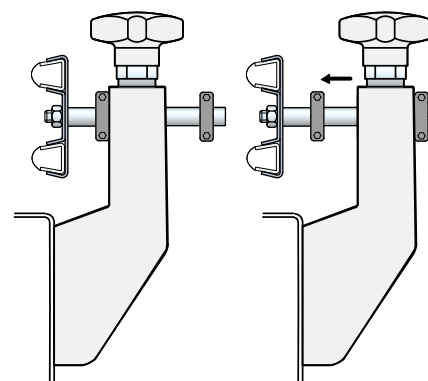

• **Assembly Part. S0612 (with square bore)**

- Ideal for the locking of MatTop® sprockets.
- Version in reinforced Polyamide PA FV, gives better resistance at high temperatures.
- Version in reinforced Polypropylene PP FV, gives better resistance against chemical agents.

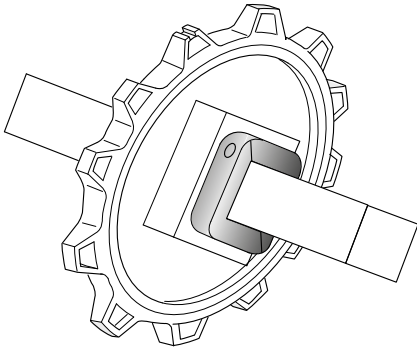

■ **Split shaft collar (with square bore)**

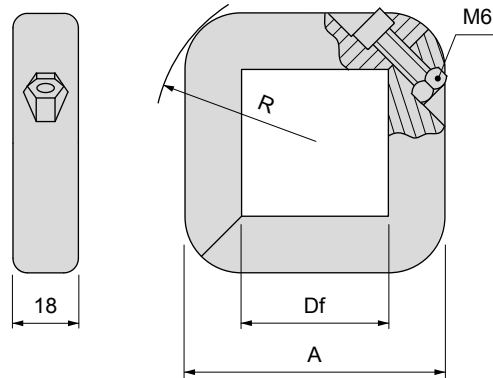

Part. S0612

Square bore Df		Material Polyamide PA FV (black)	Code	A mm	R mm
mm	inch				
Version with metric bore					
40x40	-		692952	72	44
Version with inch bore					
-	1 1/2"		692942	72	44
-	2 1/2"		692972	95	58

- Material tightening bolt: austenitic stainless steel.
- Max recommended tightening torque: 0,5 Kgm.
- Packaging: 24 pieces.

Part. S0075



Winding tensioner

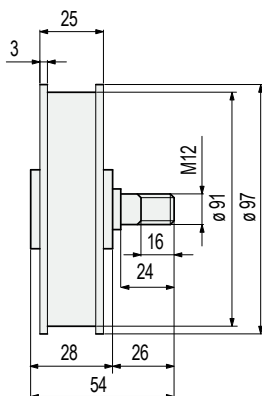

Load gr.	Winding travel mm	Direction of travel	Code
0+4000	2500	right	672642N
		left	672652N

- Noise reduction.

* = Unwinding the spring, the load is almost constant 10/20% (loss of load).

- Material: pulley in reinforced polyamide PA FV (black), pin in brass.

- Packaging: 4 pieces.

Assembly of Part. S0075

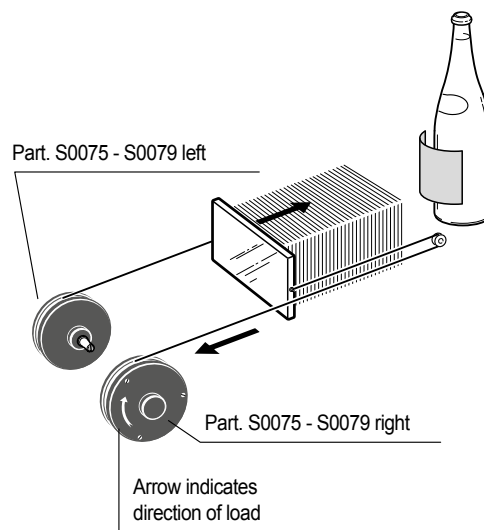

Part. S0837

■ Technical information



Patent Pending

Code	Weight kg
640783	0,68

- Operating unit SGA™, on the positioning roller and fastening support in black acetalic POM.
- Safety cover in orange Polypropylene PP.
- Stop plate, rod clamp and M22 nut in stainless steel.
- Quick coupling in plastic.
- Mini-cylinder ISO 6432.
- Packaging: 4 pieces.

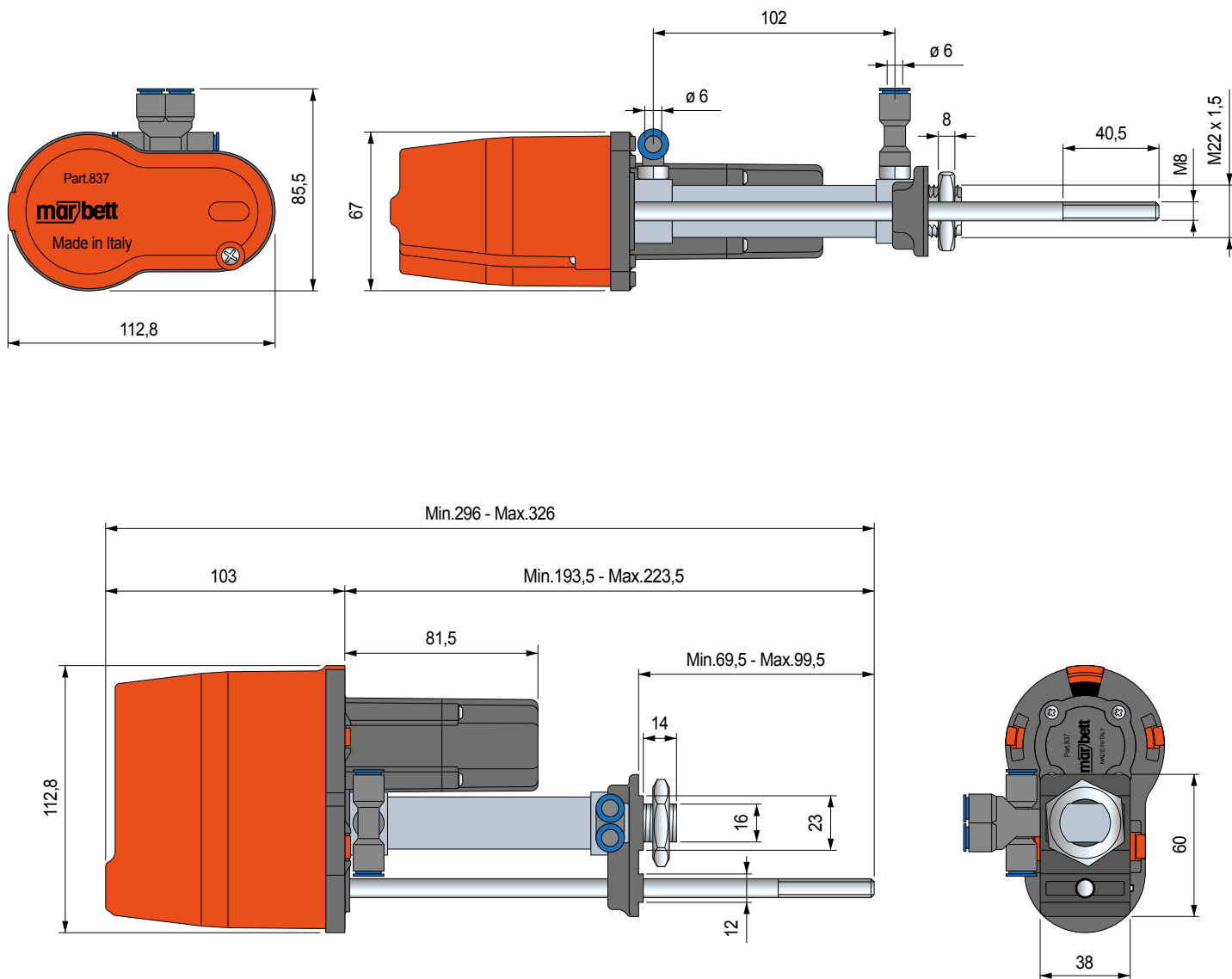

■ Component's description

Part. **S0837**

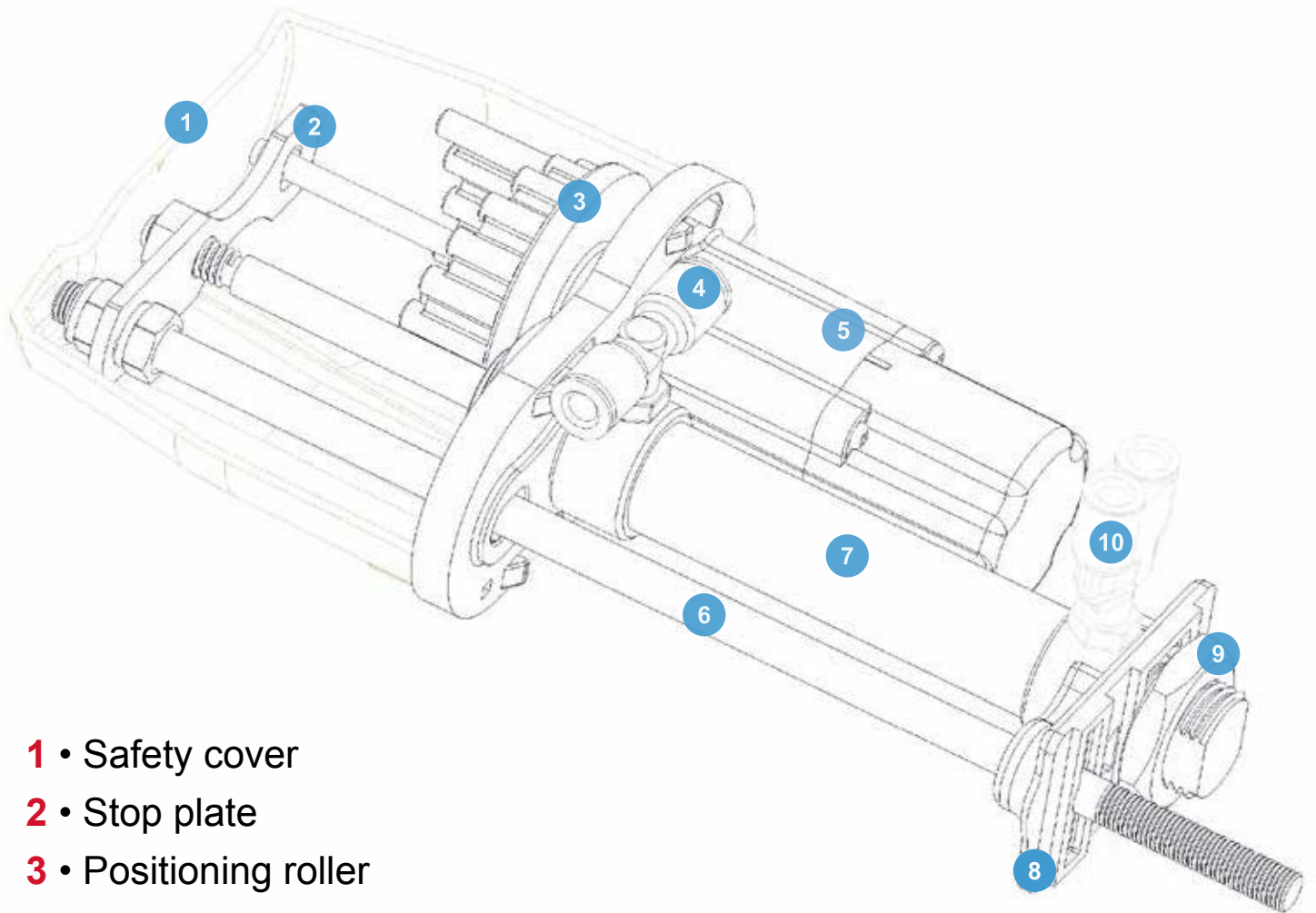

- 1 • Safety cover
- 2 • Stop plate
- 3 • Positioning roller
- 4 • Quick coupling “T” 1/8 GAS
- 5 • **SGA™** operating unit
- 6 • Rod clamp
- 7 • Mini-cylinder ISO 6432
- 8 • Mounting support
- 9 • M22 nut
- 10 • Quick coupling “Y” 1/8 GAS

Part. S0837

■ Installation on compressed air conveyors

Each unit can be assembled on bored or slotted supporting profiles, based on the sizes suggested in the figures below.

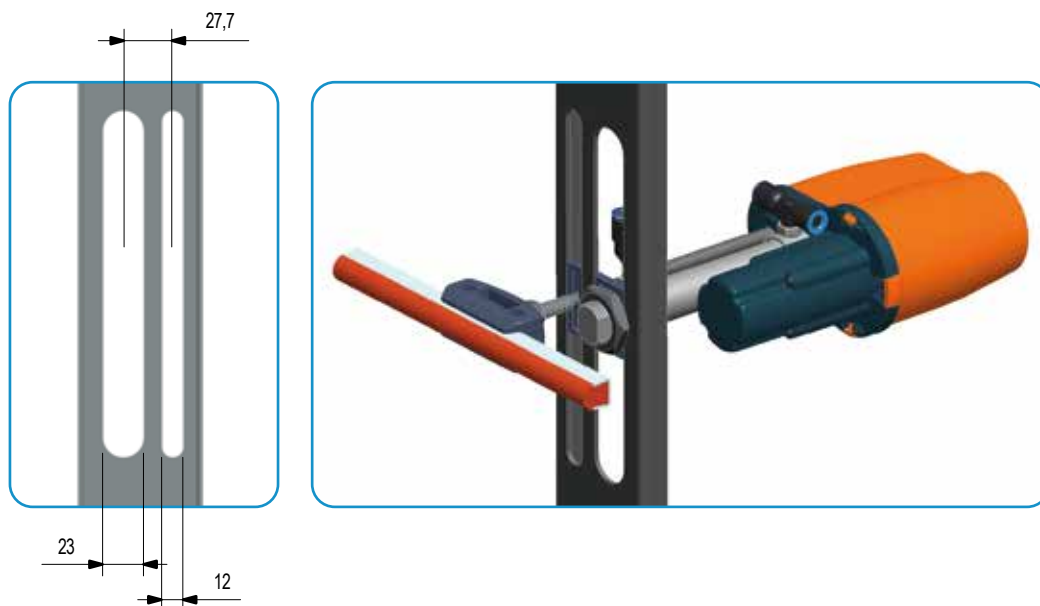

Example of installation of SGA™ system (Side Guide Adjustment™) on a compressed air conveyor. Working pressure $\geq 4,5$ bar during adjustment.

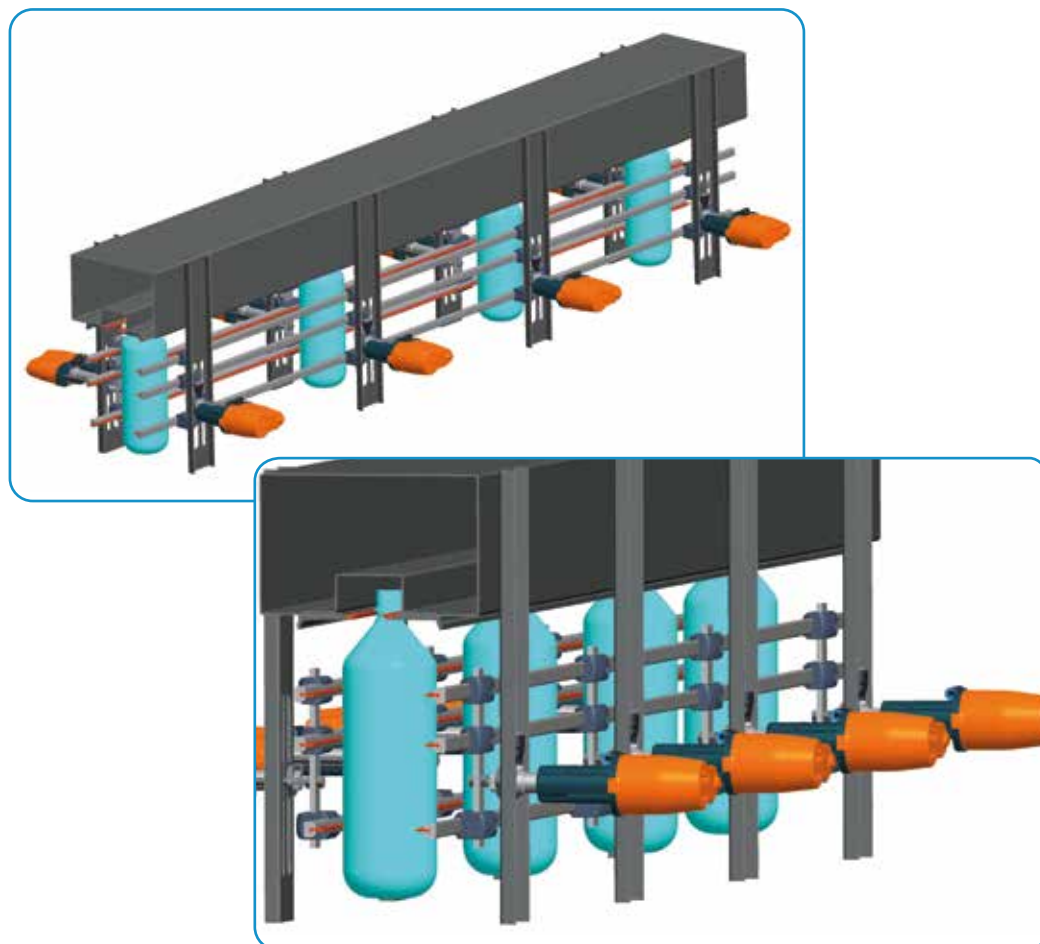

■ Installation on chain conveyors

Part. **S0837**

Each unit can be assembled on bored bars with holes according to the sizes indicated in the figures below.

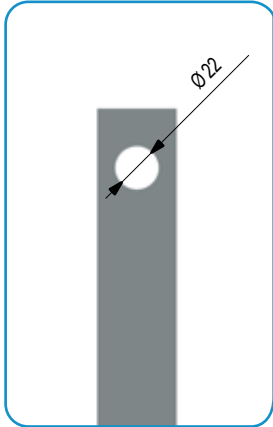

Example of installation of SGA™ system (Side Guide Adjustment™) on a chain conveyor.
Working pressure $\geq 4,5$ bar during adjustment.

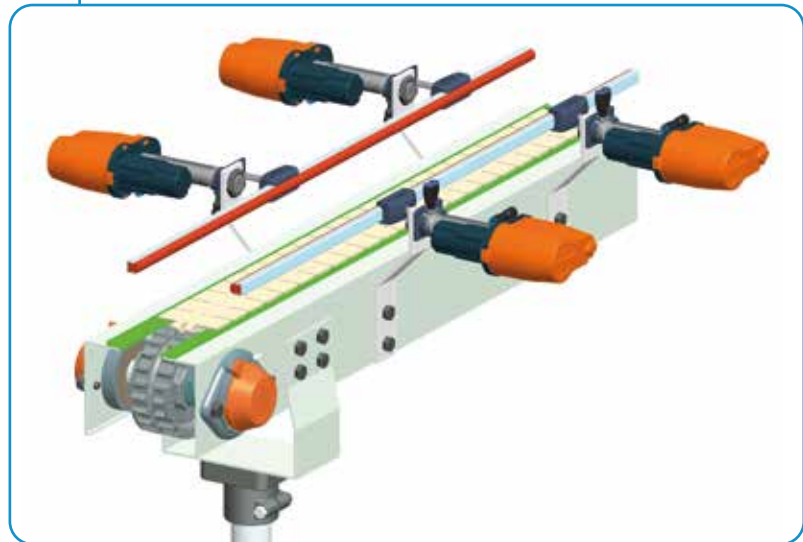

Part. S0837

Technical information

Example of side guide assembly.

Clamp Part. 215
Guides Part. 223 -
219 - 373 - 393
596 - 308
715 - 765
767 - 768
769 - 770

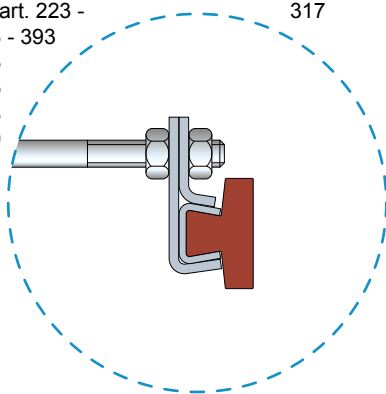

317

Clamp Part. 159 - 437 - 451

Round guides Dia. 8 - 10 - 12 - 14

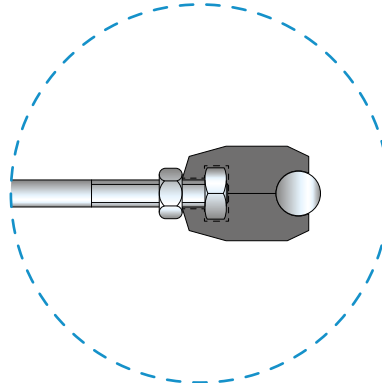

Leave min 20 mm for system movement

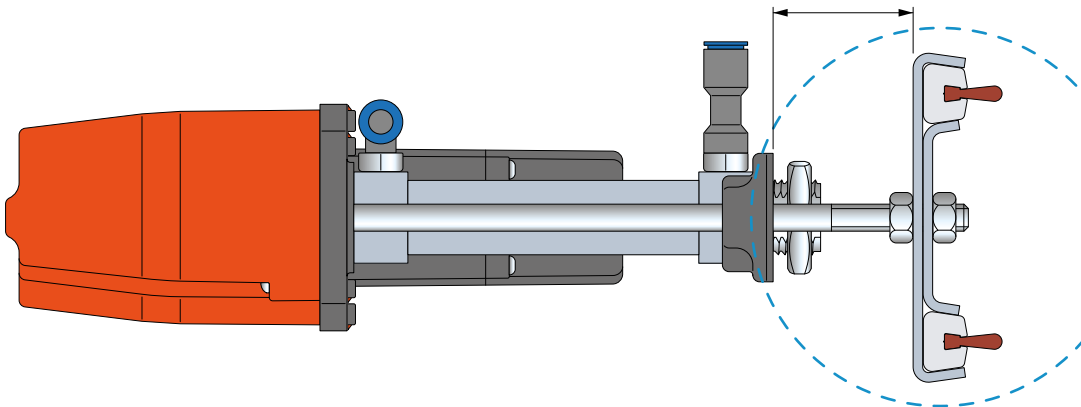

Clamp Part. 217

Guides Part.
223 - 317
219 - 373
393 - 596
308 - 715
765 - 767
768 - 769
770

Clamp Part. 211 - 446

Guides Part. 223 - 317
219 - 373 - 393
596 - 308
715 - 765
767 - 768
769 - 770

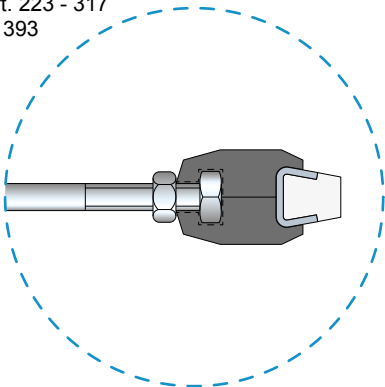

M8 nut UNI 5589-65

Guides Part. 756 - 757 - 856 - 868

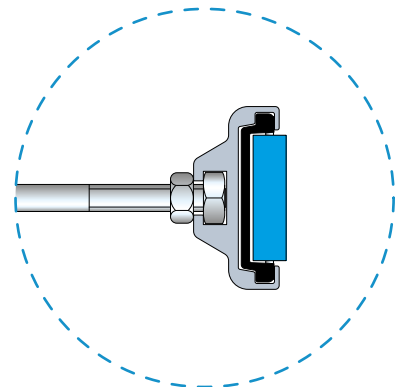

M8 nut UNI 5589-65

Guides Part. 346 - 832

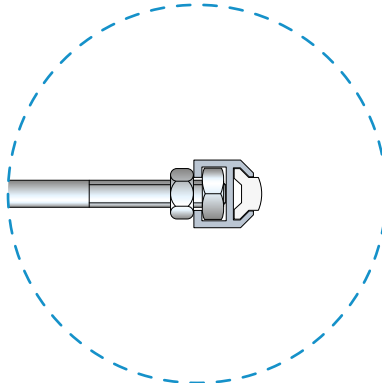

Assembly drawing 1

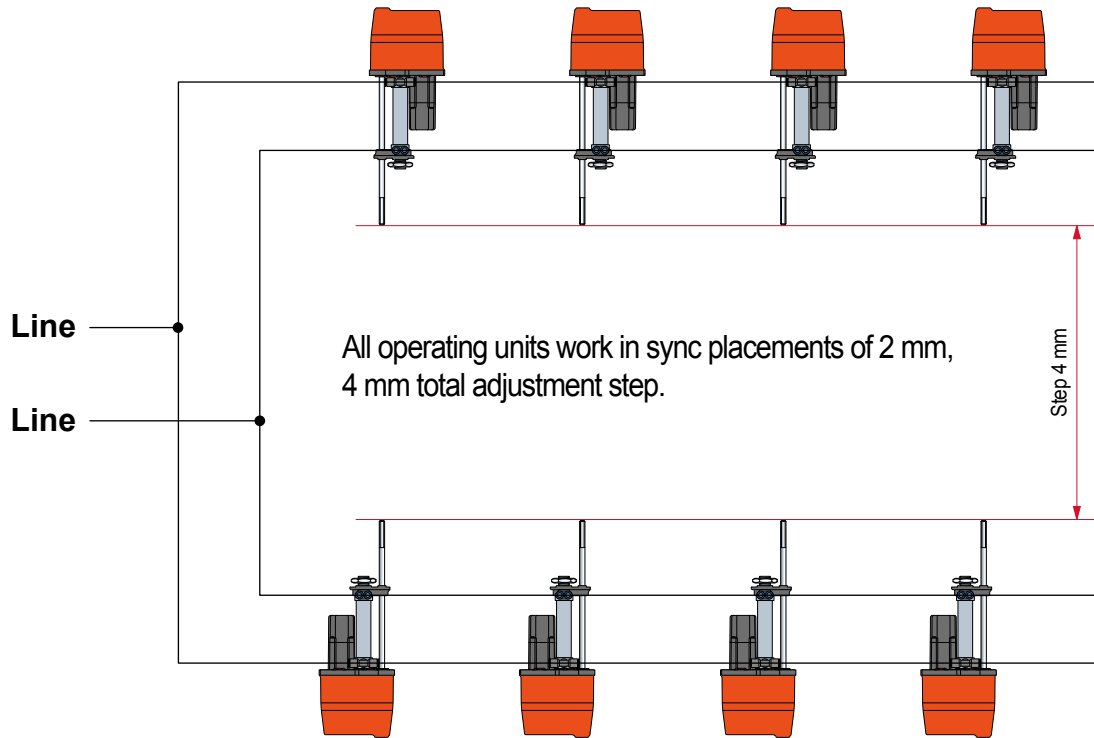

Assembly drawing 2

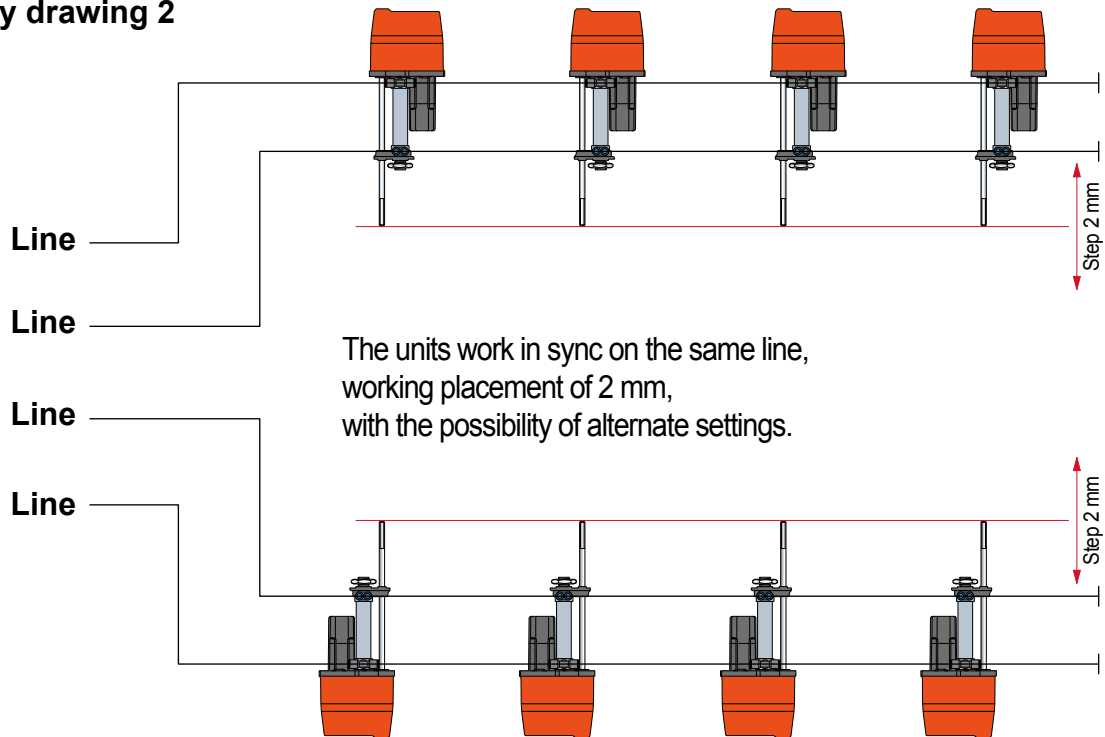

Calculation of thermal expansion

$$L_t = L_0 \cdot [1 + a \cdot (T - 20\text{ }^\circ\text{C})]$$

L_t = final length (mm.)
 L_0 = initial length (mm.)
 a = coefficient of linear expansion.
 T = operating temperature ($^\circ\text{C}$).
 $20\text{ }^\circ\text{C}$ = ambient temperature.

Example :
 a guide having initial length $L_0 = 1000$ mm, coefficient of linear expansion 2×10^{-4} , and an operating temperature of $70\text{ }^\circ\text{C}$, expands by :

$$L_t = 1000 \text{ mm} \cdot [1 + 0,0002 \cdot (70\text{ }^\circ\text{C} - 20\text{ }^\circ\text{C})] = 1010 \text{ mm}$$

Material characteristics

Polyamide PA

- An extremely tough material with excellent dimensional stability even at relatively high temperatures • Good resistance to chemical attack • Inflammability : 94HB.

Reinforced polyamide PA FV

- This material offers improved ductile strength compared with PA polyamide, as well as improved rigidity and dimensional stability • Operating temperatures can also be higher • Inflammability : 94HB.

Polypropylene PP

- Ideal for use at high temperatures • High resistance to chemical attack • Reduced mechanical characteristics • Inflammability : 94HB.

Reinforced polypropylene PP FV

- This material offers better dimensional stability and rigidity than PP polypropylene as well as better mechanical strength • Inflammability : 94HB.

Polyethylene PE (UHMWPE)

- This is the plastic material which is most suited to the manufacture of lateral guides subject to sliding contact, thanks to an extremely low coefficient of friction, excellent wear resistance and zero absorption (important in water lubricated applications) • PE polyethylene also offers high resistance to chemical attack and good sound absorbing qualities • Inflammability : 94HB.

Polyethylene ULF (UHMWPE + solid lubricant)

- Compared to polyethylene PE offers a reduced friction coefficient, with a consequent higher wear resistance • Do not leave traces on the container • Inflammability : 94 HB.

Acetal POM

- Acetalic resins are among the strongest and most resistant thermoplastic materials known • The most important characteristics of these materials are excellent ductile strength, impact resistance, rigidity, and dimensional stability • These materials also resist humidity and attack by most chemical agents • The materials cannot be used in continuous contact with steam or hot water at temperatures above $60\text{ }^\circ\text{C}$ • Inflammability : 94 HB.

Acetal Rex LF®

- This material conserves the same characteristics of POM acetalic • The addition of a self-lubricating agent, however, gives an extremely low coefficient of friction and excellent wear resistance • Rex LF® acetalic has the same limitations as POM acetalic as far as continuous contact with hot water and steam are concerned • Inflammability : 94HB.

Austenitic stainless steel

- Austenitic stainless steel offering excellent corrosion and oxidation resistance • Ideal for the food industry, dairy and cheese production, beer production, and the pharmaceutical industry • Austenitic stainless steel is cold rolled and responsive to magnets.

Zinc plated steel

- Galvanically zinc coated steel • Galvanization thickness 7 microns.

Nickel plated brass

- Good resistance to chemicals • Humid and wet environments.

Position of chain guide profiles for TableTop® chains

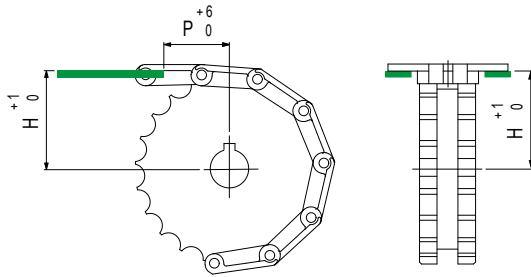

Chain	H mm	P mm
512 - 802 - 805 - 812 - 815 - 820 - 821 - 881 - 881 M - 8811 - 8811 TAB - SLBP 821	(Dp : 2) + 3,2	40
831 - XLBP 831		
880 - 880 TAB - 880 BO	(Dp : 2) + 3,6	40
879 - 879 TAB - 879 BO - LBP 879 BO		
882 - 882 TAB - SLBP 882 TAB - LBP 883	(Dp : 2) + 4,8	40
866 - 963 - 1864 - 1873 - 1874 - 2873 - 3873		
1700K - 1700TABK - AC1700K - 1701 - 1790K - 1701TABK - 1702 - 1716K - 1710K - 1710TABK - 1713K - 1713TABK	(Dp : 2) - 12	50
Dp = primitive diameter of drive sprocket - mm.		

Position of chain guide profiles for MatTop® chains

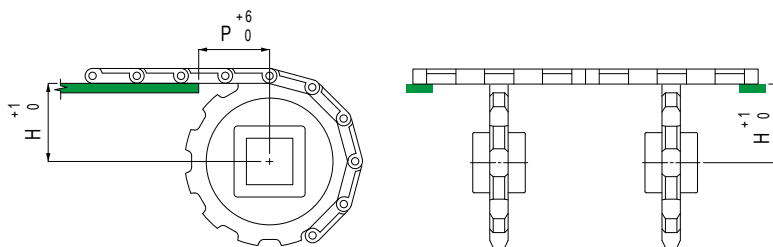

Chain	H mm	P mm
1505 - 1506	(Dp : 2) - 4,95	15
2100	(Dp : 2) - 4,37	25
4705 - 4706 - 4707 - 4705 Vacuum - 4803 - 5705 - 5706	(Dp : 2) - 6,35	38
4812	(Dp : 2) - 5,2	38
4809	(Dp : 2) - 7,9	57
5935 - 5936 - 5935 Vacuum - 8505 - 8506	(Dp : 2) - 4,35	19
5996 - 5997 - 5998	(Dp : 2) - 9,1	57
6390 - 6391 - 6392	(Dp : 2) - 7,0	50
7705 - 7706	(Dp : 2) - 6,35	25
7956	(Dp : 2) - 6,35	32
Dp = primitive diameter of drive sprocket - mm.		

Position of transfer modules
 Part. S0567 - S0568 - S0569
 S0847 - S0848 - S0849

• Head to tail transfer

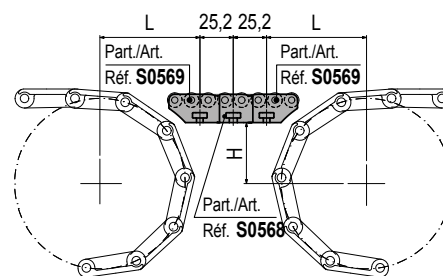
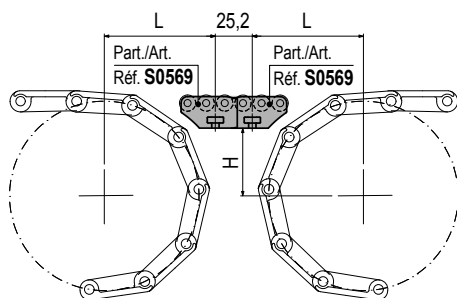
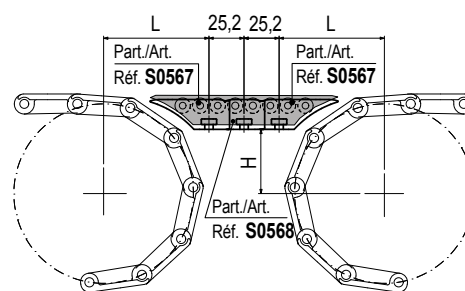
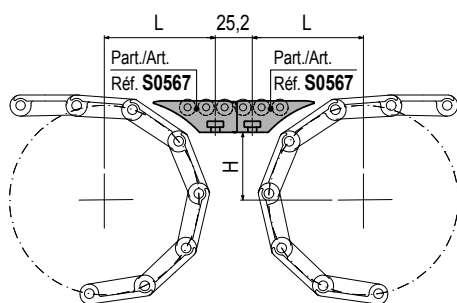

• 90° transfer

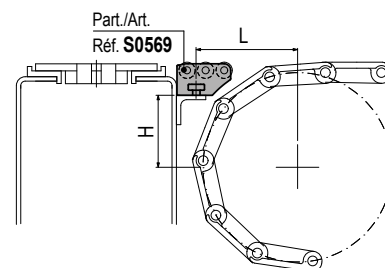
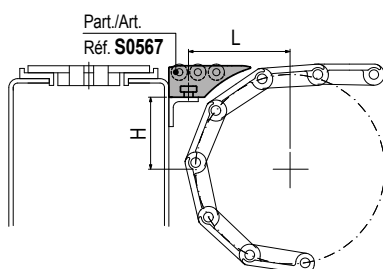

H, L dimensions for
 TableTop® chains

Chain	Z 15		Z 17		Z 19		Z 21		Z 23		Z 25		Z 27		Z 29	
	H	L	H	L	H	L	H	L	H	L	H	L	H	L	H	L
802 - 805 - 812 - 815 - 881	30,9	64,6	36,8	65,8	42,8	67,0	48,7	68,1	54,7	69,2	60,7	70,2	66,7	73,0	72,7	75,3
881 M - 8811 - 8811 TAB	30,9	64,6	36,8	65,8	42,8	67,0	48,7	68,1	54,7	69,2	60,7	70,2	66,7	73,0	72,7	75,3
512	45,2	67,4	53,2	68,9	61,3	70,3	69,3	74,0	-	-	-	-	-	-	-	-
1864 - 1874 - 4874	37,3	73,2	43,3	74,8	49,4	76,2	55,4	77,6	61,5	75,4	67,5	77,9	-	-	-	-
820	31,5	65,4	37,4	66,7	43,4	67,9	49,3	69,0	55,3	70,1	61,3	71,3	67,3	73,7	73,3	76,0
821	32,3	65,8	38,2	67,1	44,2	68,3	50,1	69,4	56,1	70,6	62,1	71,6	68,1	72,7	74,1	73,7
843	17,1	65,9	21,2	67,1	25,2	68,2	29,2	69,3	33,2	70,3	37,3	71,3	-	-	-	-
845	17,1	63,9	21,2	64,9	25,2	66,0	29,2	67,0	33,2	67,9	37,3	68,8	-	-	-	-
963	37,3	73,5	43,3	75,0	49,4	76,4	55,4	77,8	61,5	75,5	67,5	78,1	-	-	-	-
1873 - 1853 - 853	37,3	68,6	43,3	69,9	49,4	71,2	55,4	72,3	61,5	72,5	67,5	74,9	73,5	77,3	-	-
1843	17,9	63,9	22,0	64,9	26,0	66,0	30,0	66,9	34,0	67,9	38,1	68,8	-	-	-	-
812 Rub. Top - 881 Rub. Top	32,9	65,0	38,8	66,2	44,8	67,3	50,7	68,4	56,7	69,5	62,7	71,4	68,7	73,8	74,7	76,1
802 Rub. Top	33,9	65,2	39,8	66,4	45,8	67,5	51,7	68,6	57,7	69,7	63,7	71,8	69,7	74,2	75,7	76,5
HFP 820	33,5	65,1	39,4	66,3	45,4	67,5	51,3	68,6	57,3	69,6	63,3	71,6	69,3	74,0	75,3	76,3
HFP 821	34,3	65,3	40,2	66,5	46,2	67,6	52,1	68,7	58,1	69,7	64,1	72,0	70,1	74,3	76,1	76,6
HFP 867 - HFP 1877 - HFP 1873	40,3	66,5	46,3	67,6	52,4	68,7	58,4	69,8	64,5	72,1	70,5	74,5	76,5	76,8	-	-
SLBP 821	47,3	67,8	53,2	68,9	59,2	69,9	65,1	72,4	71,1	74,7	77,1	77,0	-	-	-	-

Chain	Z 9		Z 10		Z 11		Z 12		Z 13		Z 14		Z 15	
	H	L	H	L	H	L	H	L	H	L	H	L	H	L
880 TAB, 879 TAB	40,8	66,6	46,7	67,7	52,7	68,8	58,7	69,9	64,7	72,2	70,7	74,6	76,7	76,8
882 TAB	42,7	66,9	48,6	68,1	54,6	69,1	60,6	70,2	-	-	-	-	-	-
LPC 279	50,2	68,3	56,1	69,4	62,1	71,2	68,1	73,5	74,1	75,8	-	-	-	-
HFP 880 TAB	42,8	67,0	48,7	68,1	54,7	69,2	60,7	70,2	66,7	73,0	72,7	75,3	-	-
HFP 882 TAB	45,2	67,4	51,1	68,5	57,1	69,6	63,1	71,6	-	-	-	-	-	-
SLBP 882 TAB	57,2	69,6	63,1	71,6	69,1	73,9	75,1	76,2	-	-	-	-	-	-

Chain	Z 12		Z 16		Z 21		Z 23		Z 24		Z 25		Z 27		Z 32	
	H	L	H	L	H	L	H	L	H	L	H	L	H	L	H	L
1505 - 1506	11,5	60,0	20,9	62,3	-	-	-	-	40,0	66,4	-	-	-	-	59,0	69,9
4705 - 4706 - 5705 - 5706	57,5	69,6	-	-	48,5	68,0	54,5	69,1	57,5	69,6	60,5	70,2	66,5	72,9	-	-
HFP 5705	-	-	-	-	51,0	68,5	57,0	69,9	60,0	70,1	63,0	71,5	69,0	73,9	-	-

H, L dimensions for MatTop® chains

Chain	Z 7		Z 8		Z 9		Z 10		Z 11		Z 12		Z 19		Z 19	
	H	L	H	L	H	L	H	L	H	L	H	L	H	L	H	L
2100	-	-	-	-	-	-	-	-	27,0	63,7	-	-	9,2	59,3	59,1	69,9
4812	-	-	32,5	64,9	-	-	-	-	-	-	56,3	69,4	-	-	-	-
5996	52,5	68,8	-	-	70,1	74,3	-	-	-	-	-	-	-	-	-	-
6390 - 6391 - 6392	-	-	49,8	68,3	-	-	65,4	72,5	-	-	-	-	-	-	-	-

Chain	Z 10		Z 16		Z 18		Z 21		Z 24		Z 25		Z 31			
	H	L	H	L	H	L	H	L	H	L	H	L	H	L		
5935 - 5936 - 8505 - 8506	13,0	60,4	-	-	-	-	-	-	55,6	69,3	58,6	69,8	76,9	76,9		
7705 - 7706	-	-	49,0	68,1	57,0	69,6	69,1	73,9	-	-	-	-	-	-		

Chain	Z 28			
	H	L		
500	38,6	66,1		
505	40,6	66,5		

H, L dimensions for MCC chains

Chain	Z 10		Z 12		Z 13		Z 15		Z 16		Z 18		Z 20		Z 21	
	H	L	H	L	H	L	H	L	H	L	H	L	H	L	H	L
1000	-	-	31,0	64,6	-	-	-	-	47,0	67,8	55,0	69,2	63,1	70,6	-	-
1005	-	-	-	-	-	-	-	-	-	-	57,0	69,6	-	-	69,1	73,9
1050	-	-	-	-	-	-	-	-	54,8	69,2	62,8	71,5	-	-	-	-
1055	-	-	-	-	-	-	-	-	58,8	69,9	66,8	73,1	-	-	-	-
1255	35,3	65,5	-	-	50,2	68,4	60,3	70,1	65,3	72,4	-	-	-	-	-	-

Position of transfer modules
Part. S0672 - S0568 - S0846

• Head to tail transfer

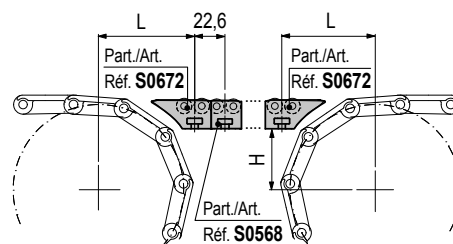
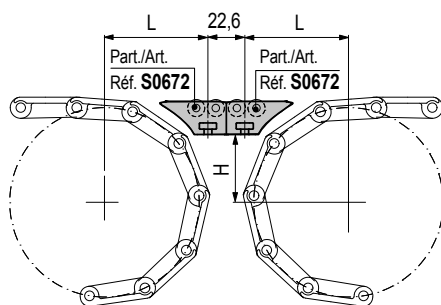

• 90° transfer

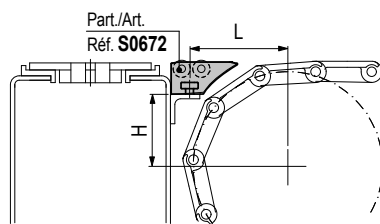

H, L dimensions for
TableTop® chains

Chain	Z 15		Z 17		Z 19		Z 21		Z 23		Z 25		Z 27		Z 29	
	H	L	H	L	H	L	H	L	H	L	H	L	H	L	H	L
802 - 805 - 812 - 815 - 881	30,9	56,8	36,8	58,2	42,8	60,9	48,7	63,7	54,7	66,3	60,7	68,8	66,7	71,2	72,7	73,5
881 M - 8811 - 8811 TAB	30,9	56,8	36,8	58,2	42,8	60,9	48,7	63,7	54,7	66,3	60,7	68,8	66,7	71,2	72,7	73,5
512	45,2	62,0	53,2	65,6	61,3	69,0	69,3	72,2	-	-	-	-	-	-	-	-
1864 - 1874 - 4874	37,3	65,0	43,3	65,3	49,4	68,2	55,4	70,9	61,5	73,6	67,5	76,1	-	-	-	-
820	31,5	57,6	37,4	59,0	43,4	61,6	49,3	64,3	55,3	67,0	61,3	69,5	67,3	71,9	73,3	74,2
821	32,3	58,0	38,2	59,4	44,2	62,1	50,1	64,8	56,1	67,4	62,1	69,9	68,1	72,3	74,1	74,7
843	17,1	57,3	21,2	58,6	25,2	59,8	29,2	61,0	33,2	62,1	37,3	63,2	-	-	-	-
845	17,1	55,4	21,2	56,6	25,2	57,8	29,2	58,9	33,2	59,9	37,3	60,9	-	-	-	-
963	37,3	65,2	43,3	65,4	49,4	68,3	55,4	71,1	61,5	73,7	67,5	76,3	-	-	-	-
1873 - 1853 - 853	37,3	60,7	43,3	62,6	49,4	65,4	55,4	68,1	61,5	70,7	67,5	73,1	73,5	75,5	-	-
1843	17,9	55,5	22,0	56,7	26,0	57,8	30,0	58,9	34,0	59,9	38,1	60,9	-	-	-	-
812 Rub. Top - 881 Rub. Top	32,9	57,3	38,8	58,6	44,8	61,9	50,7	64,6	56,7	67,1	62,7	69,6	68,7	72,0	74,7	74,3
802 Rub. Top	33,9	57,5	39,8	58,8	45,8	62,3	51,7	65,0	57,7	67,5	63,7	70,0	69,7	72,4	75,7	74,7
HFP 820	33,5	57,4	39,4	58,8	45,4	62,1	51,3	64,8	57,3	67,4	63,3	69,8	69,3	72,2	75,3	74,5
HFP 821	34,3	57,6	40,2	58,9	46,2	62,5	52,1	65,2	58,1	67,7	64,1	70,2	70,1	72,5	76,1	74,8
HFP 867 - HFP 1877 - HFP 1873	40,3	59,0	46,3	62,6	52,4	65,3	58,4	67,8	64,5	70,3	70,5	72,7	76,5	75,0	-	-
SLBP 821	47,3	63,0	53,2	65,6	59,2	68,2	65,1	70,6	71,1	72,9	77,1	75,2	-	-	-	-

Chain	Z 9		Z 10		Z 11		Z 12		Z 13		Z 14		Z 15	
	H	L	H	L	H	L	H	L	H	L	H	L	H	L
880 TAB, 879 TAB	40,8	59,1	46,7	62,8	52,7	65,4	58,7	68,0	64,7	70,4	70,7	72,8	76,7	75,0
882 TAB	42,7	60,9	48,6	63,6	54,6	66,2	60,6	68,7	-	-	-	-	-	-
LPC 279	50,2	64,3	56,1	66,9	62,1	69,4	68,1	71,7	74,1	74,0	-	-	-	-
HFP 880 TAB	42,8	60,9	48,7	63,7	54,7	66,3	60,7	68,8	66,7	71,2	72,7	73,5	-	-
HFP 882 TAB	45,2	62,1	51,1	64,7	57,1	67,3	63,1	69,8	-	-	-	-	-	-
SLBP 882 TAB	57,2	67,3	63,1	69,8	69,1	72,1	75,1	74,4	-	-	-	-	-	-

Chain	Z 12		Z 16		Z 21		Z 23		Z 24		Z 25		Z 27		Z 32	
	H	L	H	L	H	L	H	L	H	L	H	L	H	L	H	L
1505 - 1506	11,5	51,5	20,9	54,2	-	-	-	-	40,0	58,9	-	-	-	-	59,0	68,1
4705 - 4706 - 5705 - 5706	57,5	67,5	-	-	48,5	63,6	54,5	66,2	57,5	67,5	60,5	68,7	66,5	71,1	-	-
HFP 5705	-	-	-	-	51,0	64,7	57,0	67,3	60,0	68,5	63,0	69,7	69,0	72,1	-	-

H, L dimensions for MatTop® chains

Chain	Z 7		Z 8		Z 9		Z 10		Z 11		Z 12		Z 19		Z 19	
	H	L	H	L	H	L	H	L	H	L	H	L	H	L	H	L
2100	-	-	-	-	-	-	-	-	27,0	55,8	-	-	9,2	50,8	59,1	68,1
4812	-	-	32,5	57,2	-	-	-	-	-	-	56,3	67,0	-	-	-	-
5996	52,5	65,3	-	-	70,1	72,5	-	-	-	-	-	-	-	-	-	-
6390 - 6391 - 6392	-	-	49,8	64,2	-	-	65,4	70,7	-	-	-	-	-	-	-	-

Chain	Z 10		Z 16		Z 18		Z 21		Z 24		Z 25		Z 31			
	H	L	H	L	H	L	H	L	H	L	H	L	H	L		
5935 - 5936 - 8505 - 8506	13,0	52,00	-	-	-	-	-	-	55,6	66,6	58,6	67,9	76,9	75,1		
7705 - 7706	-	-	49,0	63,8	57,0	67,3	69,1	72,1	-	-	-	-	-	-		

Chain	Z 28			
	H	L		
500	38,6	58,6		
505	40,6	59,0		

H, L dimensions for MCC chains

Chain	Z 10		Z 12		Z 13		Z 15		Z 16		Z 18		Z 20		Z 21	
	H	L	H	L	H	L	H	L	H	L	H	L	H	L	H	L
1000	-	-	31,0	56,8	-	-	-	-	47,0	62,9	55,0	66,4	63,1	69,8	-	-
1005	-	-	-	-	-	-	-	-	-	-	57,0	67,3	-	-	69,1	72,1
1050	-	-	-	-	-	-	-	-	54,8	66,3	62,8	69,7	-	-	-	-
1055	-	-	-	-	-	-	-	-	58,8	68,0	66,8	71,3	-	-	-	-
1255	35,3	57,8	-	-	50,2	64,3	60,3	68,6	65,3	70,6	-	-	-	-	-	-

ARTICULATED FEET
in reinforced polyamide**Pag. R08 - R20****ARTICULATED FEET**
GRIPPER
in reinforced polypropylene
and stainless steel**Pag. R22 - R33****ARTICULATED FEET**
in steel**Pag. R34 - R39**

FIXED FEET
in steel

Pag. R39



THREADED BUSHINGS
for round and square tubes

Pag. R40 - R41



ARTICULATED FEET
in
reinforced polyamide



Part. R0173 - Pag. R08-R09
Ø 50 • Max. load 10000 N.



Part. R0098 - Pag. R10-R11
Ø 60 • Max. load 12000 N.



Part. R0323 - Pag. R12-R13
Ø 80 • Prefitting for fixing
• Max. load 10000 N.



Part. R0133 - Pag. R14-R15
Ø 100 • Prefitting for fixing
• Max. load 13000 N.



Part. R0479 - Pag. R16-R17
Ø 110 • Prefitting for fixing
• Max. load 20000 N.



Part. R0869 - Pag. R18
Ø 124 • Prefitting for fixing
• Max. load 45000 N.

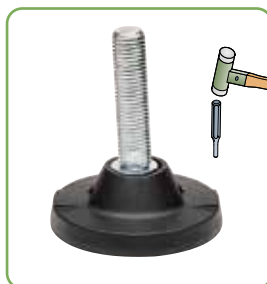

Part. R0169 - Pag. R19
Ø 124 • Prefitting for fixing
• Max. load 45000 N.



Part. R0134 - Pag. R20
Ø 100 • Prefitting for fixing
• Max. load 20000 N.



Part. R0297 - Pag. R21
Ø 124 • Prefitting for fixing
• Max. load 45000 N.



Part. R0726 - Pag. R18-R19-R21
Ø 170 • Spacer for
Réf. R0869 - R0169 - R0297.

ARTICULATED FEET GRIPPER
in
reinforced polypropylene



Part. R0626 - Pag. R22-R23
Ø 80 • Hygiene
• Customized with logo
• Max. load 12000 N.



Part. R0622 - Pag. R26-R27
Ø 100 • Hygiene
• Customized with logo
• Max. load 19500 N.



Part. R0628 - Pag. R30-R31
Ø 120 • Hygiene
• Customized with logo
• Max. load 22000 N.

ARTICULATED FEET GRIPPER
in
stainless steel



Part. R0627 - Pag. R24-R25
Ø 80 • Hygiene
• Customized with logo
• Max. load 12000 N.



Part. R0623 - Pag. R28-R29
Ø 100 • Hygiene
• Customized with logo
• Max. load 19500 N.



Part. R0629 - Pag. R32-R33
Ø 120 • Hygiene
• Customized with logo
• Max. load 22000 N.

**ARTICULATED
FEET
in
steel**



Part. R0349 - Pag. R34
 Ø 123 • N. 4 holes • Stainless steel and zinc plated steel
 • Max. load 10000 N.



Part. R0408 - Pag. R35
 Ø 160 • Painted steel
 • Max. load 50000 N.

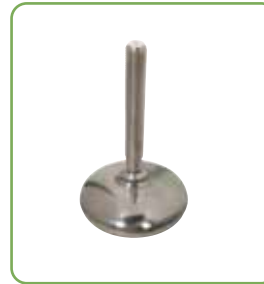

Part. R0747 - Pag. R36
 Ø 80 • Stainless steel
 • Hygiene • Max. load 25000 N.



Part. R0748 - Pag. R37
 Ø 100 • Stainless steel
 • Hygiene • Max. load 25000 N.



Part. R0749 - Pag. R38
 Ø 120 • Stainless steel
 • Hygiene • Max. load 25000 N.



Part. R0747F - Pag. R037
 Ø 80 • Stainless steel
 • Hygiene • Prefitting for fixing
 • Max. load 25000 N.



Part. R0748F - Pag. R37
 Ø 100 • Stainless steel
 • Hygiene • Prefitting for fixing
 • Max. load 25000 N.



Part. R0750S - Pag. R38
 Ø 80 • Stainless steel
 • Hygiene • Max. load 25000 N.



Part. R0750SF - Pag. R38
 Ø 80 • Stainless steel
 • Hygiene • Prefitting for fixing
 • Max. load 25000 N.

**FIXED
FEET
in
steel**

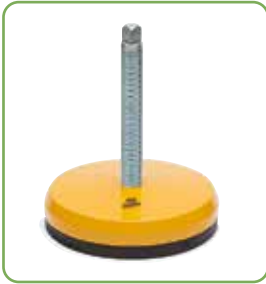

Part. R0406 - Pag. R39
Ø 123 • Painted steel
• Max. load 50000 N.

**THREADED
BUSHINGS**
for
round and
square tubes



Part. R0180 - Page R40
For round tubes
Ø 48,3-54-60.3 mm and 2"



Part. R0224 - Page R41
For square tubes 40-50 mm
and 2"

■ SPINDLE MATERIALS

Stainless steel

- High resistance to chemicals.
- Excellent resistance to oxidation.
- Operating temperature :
in air (- 70°C to + 430°C)
in hot water (+ 120°C)
- Sectors of use
Humid and corrosive environments. Environments where hygiene regulations are strict and indispensable (food and dairy industry, chemicals-pharmaceuticals, bottling). Electronics industry (where non-magnetic properties are required).

Zinc plated steel

- Operating temperature :
in air (- 40°C to + 180°C)
in hot water (+ 120°C)
- Sectors of use
Moisture-free environments with low corrosion.

Nickel plated brass

- Good resistance to chemicals.
- Operating temperature :
in air (- 40°C to + 180°C)
in hot water (+ 120°C)
- Sectors of use
Humid and wet environments.

Reinforced polyamide with steel pin

- Good resistance to chemicals.
- Operating temperature :
in air (- 5°C to + 120°C)
in hot water (+ 100°C)
- Colour: black.
- Sectors of use Industrial, packaging.

■ FOOTPLATE MATERIALS

Reinforced polyamide PA FV

- Good mechanical strength.
Able to withstand high load capacities.
- High thermal resistance.
- Good resistance to chemicals.
- Operating temperature:
in air (- 30°C to + 120°C)
in hot water (+ 100°C)
- Colour : black.
- Inflammability : 94HB.

Reinforced polypropylene PP FV

- Recommended in applications requiring high resistance to chemicals and fair mechanical properties (the load capacity is lower than reinforced polyamide).
- Operating temperature :
in air (+ 5°C to + 115°C)
in hot water (+ 115°C)
- Colour : black.
- Inflammability : 94HB.

■ ANTI-SLIP MATERIALS

NBR rubber

- Operating temperature :
in air (- 35°C to + 100°C)
in hot water (+ 80°C)
- Colour : black.
- Inflammability : 94HB

Part. R0173

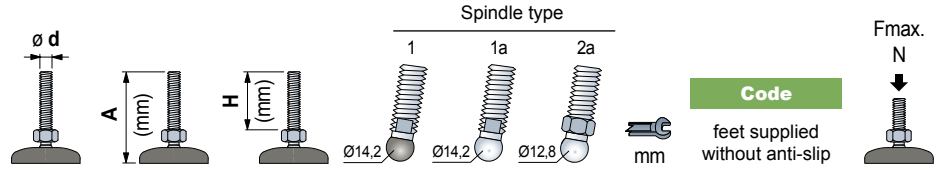

Spindle in stainless steel							Code	Fmax. N
M16	105	81	-	1a	-	13	626663	10000
	155	124	-	1a	-	13		

Spindle in zinc plated steel							Code	Fmax. N
M10	95	71	-	-	2a	12	625332	10000
M12	90	69	-	-	2a	12	625362	
	120	96	-	-	2a	12	625372	

Item code for order = Part. + Code

- Footplate material: reinforced polyamide PA FV (black).
- Note: for spindles type 1 ball in reinforced polyamide.
- Packaging: 12 pieces.
- Anti-slip supplied separately.
- On request different length.
- Fmax. = maximum applicable load in static conditions.

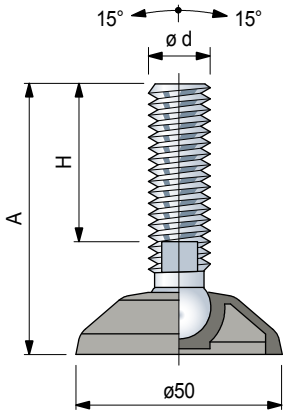

Accessories

Anti-slip

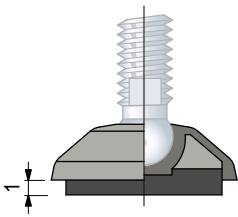

- Code: **R0000630012**.
- Material: NBR rubber (black), 70 Shore.
- Assembly: press-fit.
- Packaging: 12 pieces

Articulated Feet

in reinforced polyamide

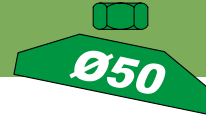

Part. R0173

		Spindle type		Code		Fmax. N
$\varnothing d$	A (mm)	H (mm)	2a	mm	feet supplied without anti-slip	
Spindle in stainless steel						
M10	95	71	2a	12	625252	10000
M12	90	69	2a	12	625262	
	155	132	2a	12	625272	



Item code for order = Part. + Code

- Footplate material: reinforced polyamide PA FV (black).
- Packaging: 12 pieces.
- Anti-slip supplied separately.
- On request different length.
- Fmax. = maximum applicable load in static conditions.

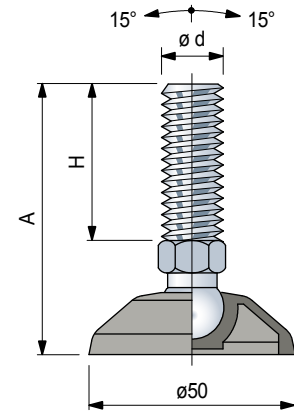

Accessories

Anti-slip

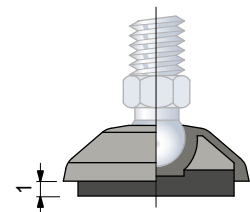

- Code: **R0000630012**.
- Material: NBR rubber (black), 70 Shore.
- Assembly: press-fit.
- Packaging: 12 pieces

Part. R0098

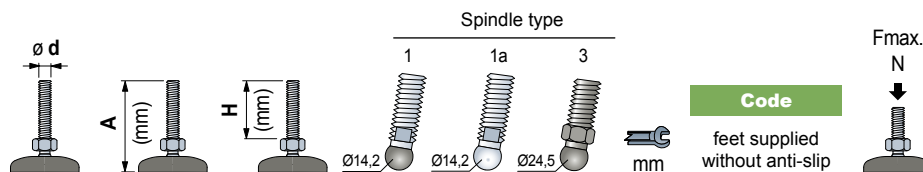

Spindle in stainless steel								Fmax. N
	A (mm)	H (mm)	Spindle type	mm	Code			
M16	100	64	-	1a	-	13	626012	10000
	115	81	-	1a	-	13	626022	
	160	124	-	1a	-	13	626032	
	185	151	-	1a	-	13	626042	
M20	120	84	-	1a	-	16	626052	
	185	149	-	1a	-	16	626062	
	245	208	-	1a	-	16	621293	
M24	250	209	-	1a	-	19	621303	

Spindle in zinc plated steel								Fmax. N
	A (mm)	H (mm)	Spindle type	mm	Code			
M16	95	61	-	1a	-	13	626102	10000
	150	116	-	1a	-	13	626122	
	185	151	-	1a	-	13	626132	
M20	185	150	-	1a	-	16	626152	
M24	240	150	-	1a	-	16	10344000	

Spindle in reinforced polyamid (black) with steel pin								Fmax. N
	A (mm)	H (mm)	Spindle type	mm	Code			
M16	100	54	-	-	3	24	61920	6000
M24	240	205	-	1a	-	19	10344000	

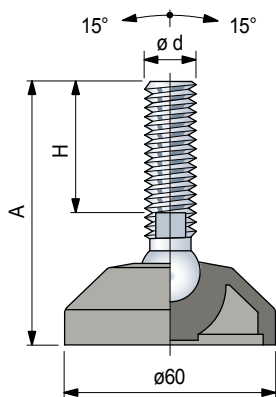

Accessories

Anti-slip

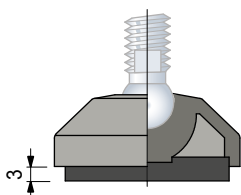

- Code: **R0000630022**.
- Material: NBR rubber (black), 70 Shore.
- Assembly: press-fit.
- Packaging: 12 pieces

Item code for order = Part. + Code

- Footplate material: reinforced polyamide PA FV (black).
- Note: for spindles type 1 ball in reinforced polyamide.
- Packaging: 24 pieces.
- Anti-slip supplied separately.
- On request different length.
- Fmax. = maximum applicable load in static conditions.

Articulated Feet

in reinforced polyamide

Ø60

REXNORD

Part. **R0098** Reinforced version

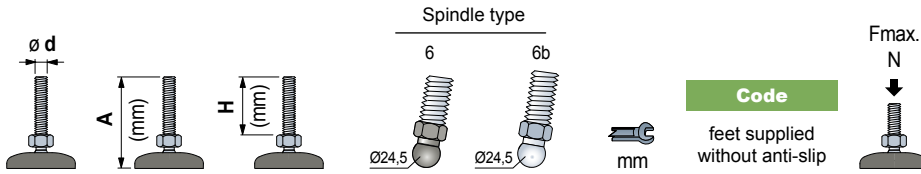

Spindle in stainless steel						
M16	150	109	-	6b	24	628792
	200	159	-	6b	24	628812
M24	220	179	-	6b	24	628872

Spindle in zinc plated steel						
M16	195	154	-	6b	24	628852

Item code for order = Part. + Code

- Footplate material: reinforced polyamide PA FV (black).
- Note: for spindles type 6 ball in reinforced polyamide.
- Packaging: 12 pieces.
- Anti-slip supplied separately.
- On request different length.
- Fmax. = maximum applicable load in static conditions.

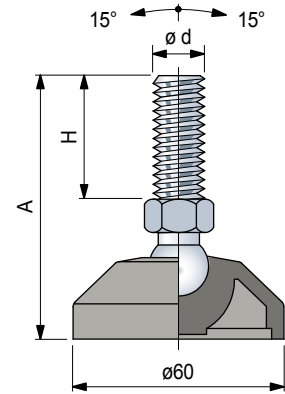

Accessories

Anti-slip

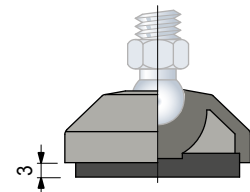

- Code: **R0000630022**.
- Material: NBR rubber (black), 70 Shore.
- Assembly: press-fit.
- Packaging: 12 pieces

Part. R0323

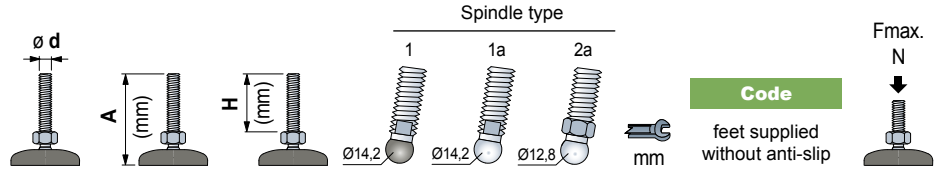

Spindle in stainless steel								Fmax. N
						Code		
M16	95	64	-	1a	-	13	626582	10000
	110	81	-	1a	-	13	626592	
	155	124	-	1a	-	13	626602	
	180	151	-	1a	-	13	626612	
M20	115	84	-	1a	-	16	626622	10000
	180	149	-	1a	-	16	626632	

Spindle in zinc plated steel								Fmax. N
							Code	
M10	95	71	-	-	2a	12	60464N	9000
M12	95	69	-	-	2a	12	62313N	
	120	96	-	-	2a	12	678941N	
M16	145	116	-	1a	-	13	626692	10000
	180	151	-	1a	-	13	626702	
M20	180	150	-	1a	-	16	626722	

Fixing holes, obtainable by breaking "diaphragm".

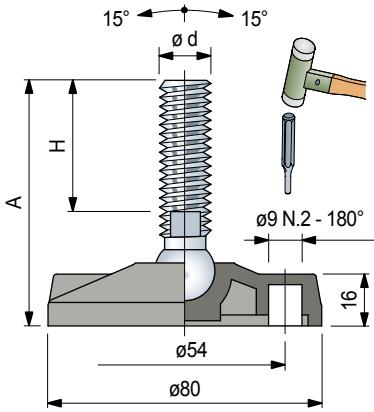

Accessories

Anti-slip

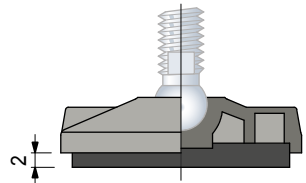

- Code: **R0000630042**.
- Material: NBR rubber (black), 70 Shore.
- Assembly: press-fit.
- Packaging: 12 pieces

Item code for order = Part. + Code

- Footplate material: reinforced polyamide PA FV (black).
- Note: for spindles type 1 ball in reinforced polyamide.
- Packaging: 12 pieces.
- Anti-slip supplied separately.
- On request different length.
- Fmax. = maximum applicable load in static conditions.

Articulated Feet

in reinforced polyamide

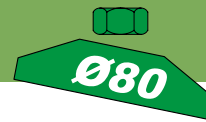

Part. R0323

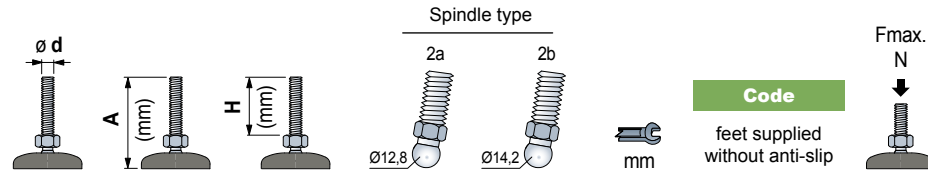

Spindle in stainless steel						
M10	95	71	2a	-	12	65686N
M12	95	69	2a	-	12	65596N
	155	132	2a	-	12	679061N

9000

Item code for order = Part. + Code

- Footplate material : reinforced polyamide PA FV (black).
- Packaging : 12 pieces.
- Anti-slip supplied separately.
- On request different length.
- Fmax. = maximum applicable load in static conditions.



Fixing holes, obtainable by breaking "diaphragm".

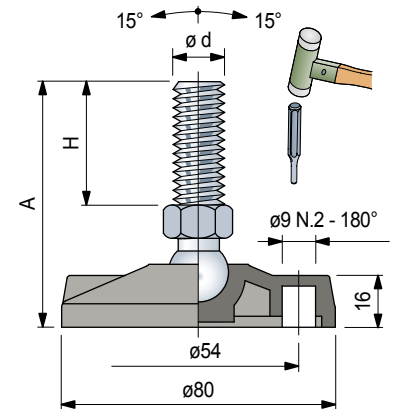

Accessories

Anti-slip

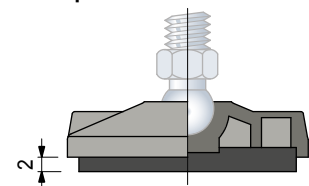

- Code: **R0000630042**.
- Material: NBR rubber (black), 70 Shore.
- Assembly: press-fit.
- Packaging: 24 pieces

Part. R0133



Fixing holes, obtainable by breaking "diaphragm".

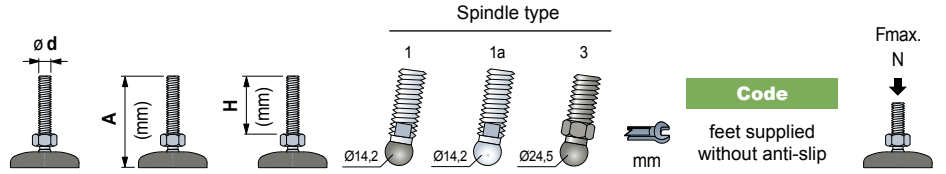
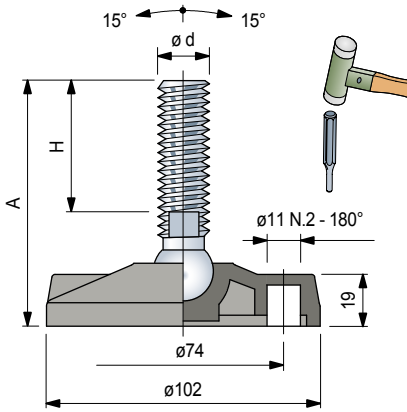

Spindle in stainless steel							
						Code	
M16	100	64	-	1a	-	13	12000
	115	81	-	1a	-	13	
	160	124	-	1a	-	13	
	185	151	-	1a	-	13	
M20	120	84	-	1a	-	16	12000
	185	149	-	1a	-	16	
	245	208	-	1a	-	16	
M24	250	209	-	1a	-	19	627133

Spindle in zinc plated steel							
						Code	
M16	95	61	-	1a	-	13	12000
	150	116	-	1a	-	13	
	185	151	-	1a	-	13	
M20	185	150	-	1a	-	16	633342

Spindle in reinforced polyamid (black) with steel pin								
						Code		
M16	100	54	-	-	3	24	627292	6000

Item code for order = Part. + Code

- Footplate material: reinforced polyamide PA FV (black).
- Note: for spindles type 1 ball in reinforced polyamide.
- Packaging: 12 pieces.
- Anti-slip supplied separately.
- On request different length.
- Fmax. = maximum applicable load in static conditions.

Accessories

Anti-slip

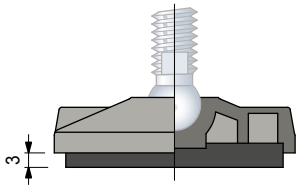

- Code: **R0000630052**.
- Material: NBR rubber (black), 70 Shore.
- Assembly: press-fit.
- Packaging: 12 pieces

Articulated Feet

in reinforced polyamide

Ø100

REXNORD

Part. R0133

Reinforced version

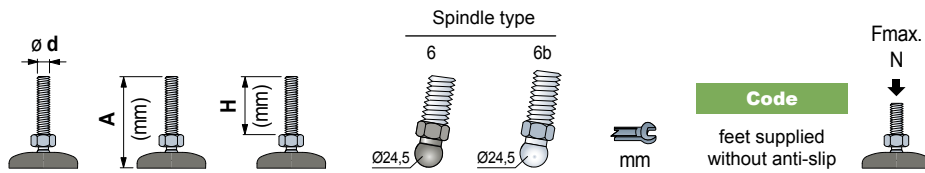

Spindle in stainless steel							13000
M12	150	103	6	-	19	679251N	
M14	150	103	6	-	19	679311N	
M16	150	109	-	6b	24	627222	
	185	144	-	6b	24	627232	
M24	220	179	-	6b	24	627282	

Spindle in zinc plated steel							
M16	195	154	-	6b	24	627352	13000

Item code for order = Part. + Code

- Footplate material: reinforced polyamide PA FV (black).
- Note: for spindles type 6 ball in reinforced polyamide.
- Packaging: 12 pieces.
- Anti-slip supplied separately.
- On request different length.
- Fmax. = maximum applicable load in static conditions.



Fixing holes, obtainable by breaking "diaphragm".

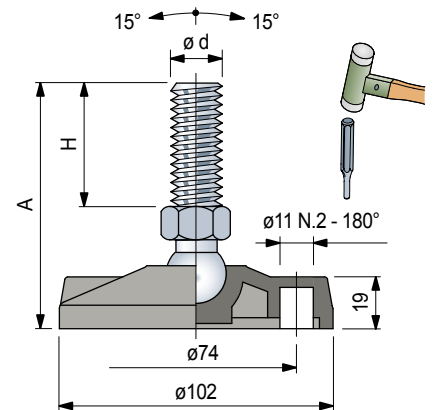

Accessories

Anti-slip

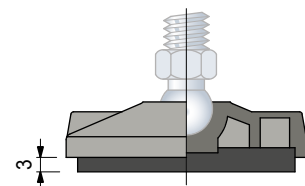

- Code: **R0000630052**.
- Material: NBR rubber (black), 70 Shore.
- Assembly: press-fit.
- Packaging: 12 pieces

Part. R0479

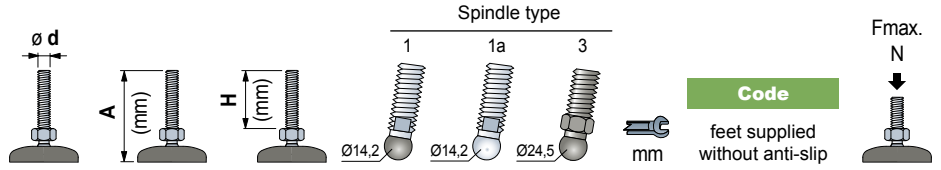

Spindle in stainless steel

M16	110	64	-	1a	-	13	633392	15000
	125	81	-	1a	-	13	633402	
	170	124	-	1a	-	13	633412	
	195	151	-	1a	-	13	633422	
M20	130	84	-	1a	-	16	633432	
	195	149	-	1a	-	16	633442	
	255	208	-	1a	-	16	627293	
M24	260	209	-	1a	-	19	627323	

Spindle in zinc plated steel

M16	105	61	-	1a	-	13	633482
	160	116	-	1a	-	13	633502
	195	151	-	1a	-	13	633512
M20	190	150	-	1a	-	16	633532
M24	195	146	-	1a	-	19	633562

Item code for order = Part. + Code

- Footplate material: reinforced polyamide PA FV (black).
- Note: for spindles type 1 ball in reinforced polyamide.
- Packaging: 12 pieces.
- Anti-slip supplied separately.
- On request different length.
- Fmax. = maximum applicable load in static conditions.

Fixing holes, obtainable by breaking "diaphragm".

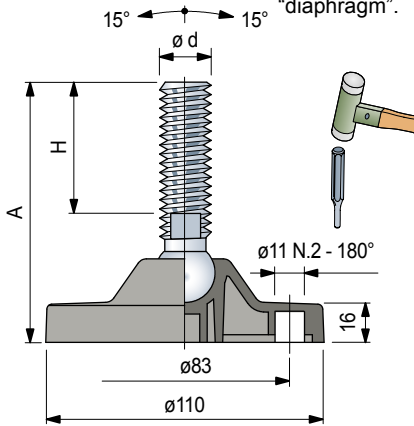

Accessories

Anti-slip

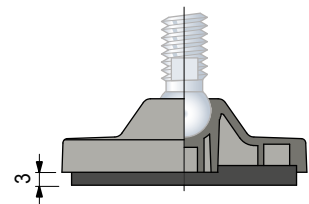

- Code: **R0000630062**.
- Material: NBR rubber (black), 70 Shore.
- Assembly: press-fit.
- Packaging: 12 pieces

Articulated Feet

in reinforced polyamide

Ø110

REXNORD

Part. R0479

Reinforced version

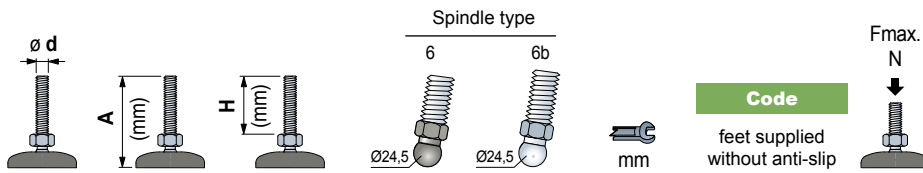

Spindle in stainless steel

	A	H		Spindle type	mm	Code
M16	160	109	-	6	24	627432
	195	144	-	6b	24	627442
M24	230	179	-	6b	24	627492

Item code for order = Part. + Code

- Footplate material: reinforced polyamide PA FV (black).
- Note: for spindles type 6 ball in reinforced polyamide.
- Packaging: 12 pieces.
- Anti-slip supplied separately.
- On request different length.
- Fmax. = maximum applicable load in static conditions.



Fixing holes, obtainable by breaking "diaphragm".

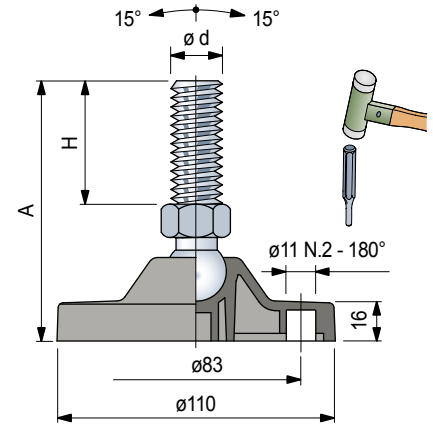

Accessories

Anti-slip

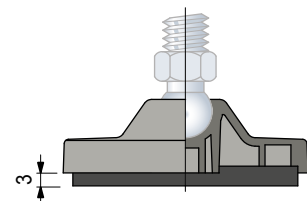

- Code: **R0000630062**.
- Material: NBR rubber (black), 70 Shore.
- Assembly: press-fit.
- Packaging: 12 pieces

Articulated Feet

in reinforced polyamide and polypropylene

Part. R0869

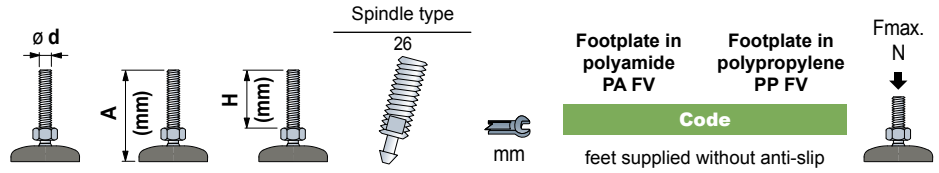

Spindle in stainless steel					Footplate in polyamide PA FV	Footplate in polypropylene PP FV	Fmax. N ↓
	A (mm)	H (mm)	Spindle type	mm	Code	Code	
M16	200	140	26	13	618933	619313	45000 (PA FV) 13000 (PP FV)
M24	200	139	26	17	618973	619353	
	260	199	26	17	618983	619363	

Spindle in zinc plated steel					Footplate in polyamide PA FV	Footplate in polypropylene PP FV	Fmax. N ↓
	A (mm)	H (mm)	Spindle type	mm	Code	Code	
M20	200	139	26	17	619153	619533	45000 (PA FV) 13000 (PP FV)
M24	350	287	26	19	619243	619623	

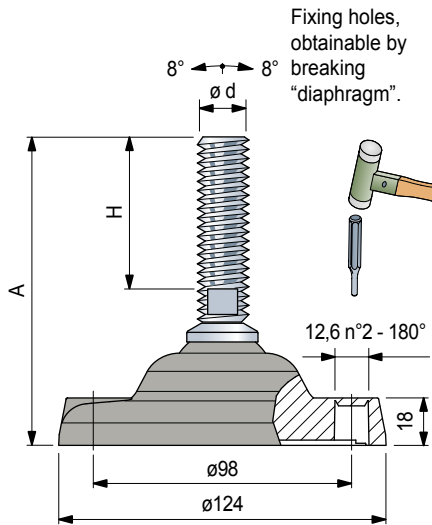

Item code for order = Part. + Code

- Footplate material: reinforced polyamide PA FV (black) and reinforced polypropylene PP FV (black).
- Packaging: 12 pieces.
- Anti-slip supplied separately (on request supplied fixed to the foot).
- On request different length.
- Fmax. = maximum applicable load in static conditions.

Accessories

Anti-slip

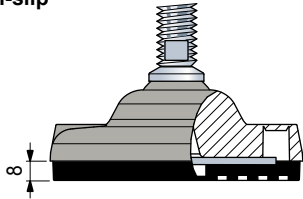

- Code with reinforcement disc: **R0000630082**.
- Code without reinforcement disc: **R0000630092**.
- Assembly: with screws for plate supplied loose.
- Material: NBR rubber (black), 80 Shore.
- Packaging: 12 pieces.

Part. R0726 - Spacer



- Code: **688772**.
- Material: acetal POM (black).
- Weight: 1,15 Kg.
- Packaging: 8 pieces.

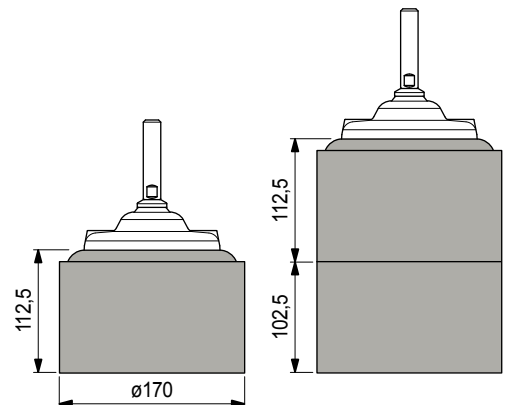

Articulated Feet

in reinforced polyamide and polypropylene

Ø124

REXNORD

Part. R0169

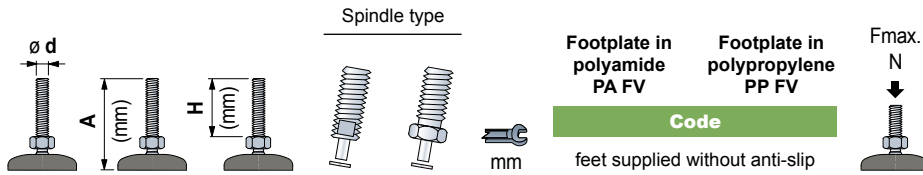

Spindle in stainless steel

	A (mm)	H (mm)				Footplate in polyamide PA FV	Footplate in polypropylene PP FV	Fmax. N
M20	205	146	-	22	30	624812	628692	45000 (PA FV) 13000 (PP FV)
M30	205	152	21	-	24	624832	628712	

Spindle in zinc plated steel

	A (mm)	H (mm)				Footplate in polyamide PA FV	Footplate in polypropylene PP FV	Fmax. N
M20	205	146	-	22	30	624862	628742	45000 (PA FV) 13000 (PP FV)
	255	195	-	22	30	624872	628752	
M24	205	152	21	-	19	624892	628772	

Item code for order = Part. + Code

- Footplate material: reinforced polyamide PA FV (black) and reinforced polypropylene PP FV (black).
- Packaging: 12 pieces.
- Anti-slip supplied separately (on request supplied fixed to the foot).
- On request different length.
- Fmax. = maximum applicable load in static conditions.

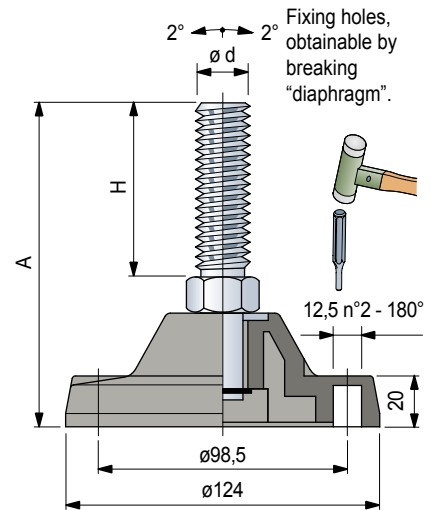

Accessories

Anti-slip

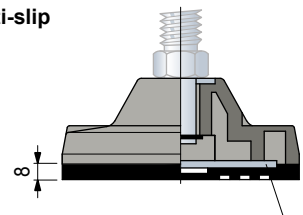

- Code with reinforcement disc: **R000630082**.
- Code without reinforcement disc: **R000630092**.
- Assembly: with screws for plate supplied loose.
- Material: NBR rubber (black), 80 Shore.
- Packaging: 12 pieces.

Part. R0726 - Spacer



- Code: **688772**.
- Material: acetal POM (black).
- Weight: 1,15 Kg.
- Packaging: 8 pieces.

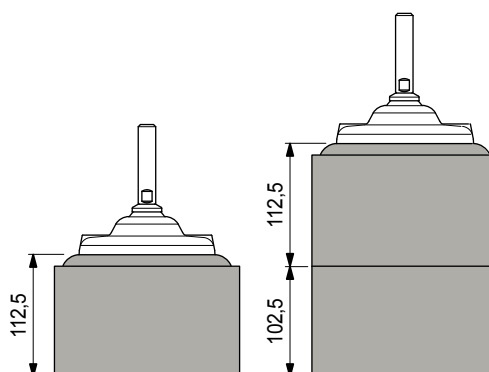

Part. R0134

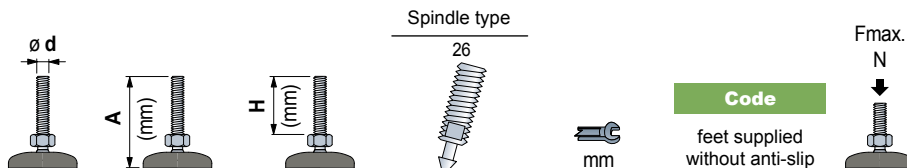

Spindle in stainless steel						
	180	140	26	13	627423	20000
M20	180	139	26	17	627433	

Spindle in z nc plated steel						
M20	150	109	26	17	627483	20000

Item code for order = Part. + Code

- Footplate material: reinforced polyamide PA FV (black).
- Packaging: 12 pieces.
- Anti-slip supplied separately.
- On request different length.
- Fmax. = maximum applicable load in static conditions.

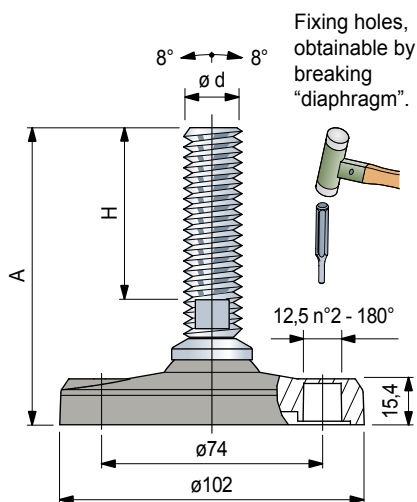

Accessories

Anti-slip

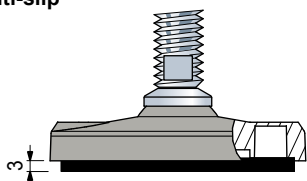

- Code: **R0000630052**.
- Material: NBR rubber (black), 70 Shore.
- Assembly: press-fit.
- Packaging: 12 pieces

Articulated Feet

in reinforced polyamide

Ø124

REXNORD

Part. R0297

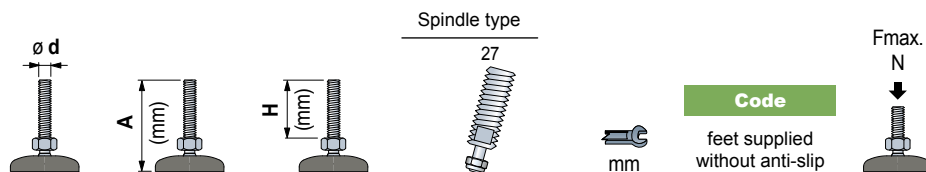

Spindle in stainless steel					
M16	210	140	27	13	45000
M20	210	140	27	17	
M30	195	125	27	24	
	250	180	27	24	

Spindle in zinc plated steel					
M20	205	140	27	17	629242N1
M30	195	125	27	24	629252N1
	250	180	27	24	629262N1

Item code for order = Part. + Code

- Footplate material: reinforced polyamide PA FV (black).
- Packaging: 12 pieces.
- Anti-slip supplied separately (on request supplied fixed to the foot).
- On request different length.
- Fmax. = maximum applicable load in static conditions.

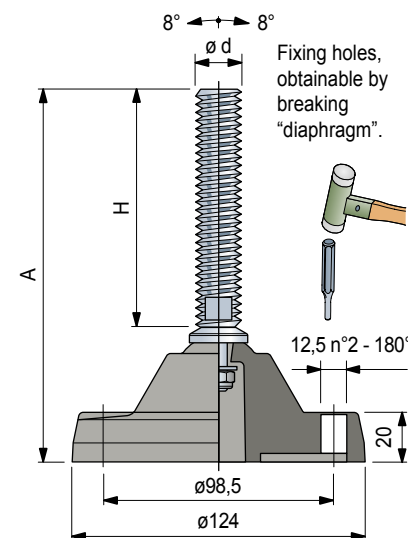

Accessories

Anti-slip

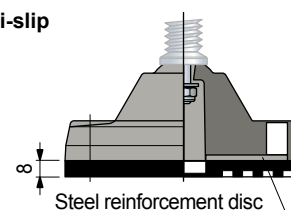

- Code with reinforcement disc: **R0000630082**.
- Code without reinforcement disc: **R0000630092**.
- Assembly: with screws for plate supplied loose.
- Material: NBR rubber (black), 80 Shore.
- Packaging: 12 pieces.

Part. R0726 - Spacer



- Code: **688772**.
- Material: acetal POM (black).
- Weight: 1,15 Kg.
- Packaging: 8 pieces.

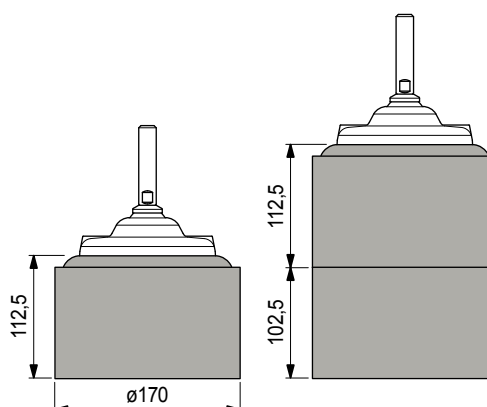

Part. R0626

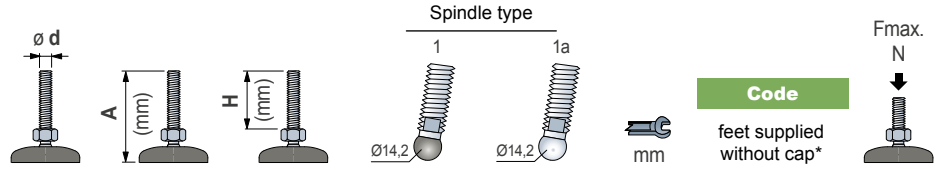

Spindle in stainless steel						
					Code	
M16	100	64	-	1a	13	641722
	115	81	-	1a	13	641732
	160	124	-	1a	13	641742
	185	151	-	1a	13	641752
M20	120	84	-	1a	16	641762
	185	149	-	1a	16	641772

10000

Spindle in zinc plated steel						
M16	95	61	-	1a	13	641812
	150	116	-	1a	13	641832
	185	151	-	1a	13	641842
M20	185	150	-	1a	16	641872

10000

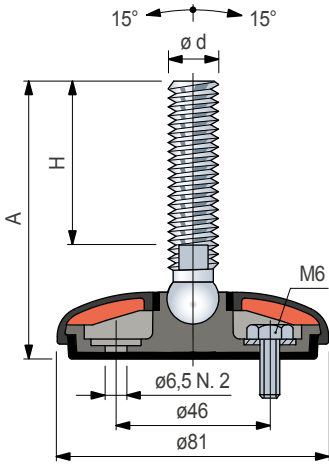

Item code for order = Part. + Code

- * = Feet are supplied without protection caps. Caps have to be ordered separately, indicating selected colour.
- Base material: reinforced polypropylene with integrated anti-slip in thermoplastic rubber grey (70 Shore).
- The sealing of the internal structure guarantees a better hygiene.
- Feet can be fixed to the floor.
- Note: for spindles type 1 ball in reinforced polyamide.
- Packaging: 24 pieces.
- On request different length.
- Fmax. = maximum applicable load in static conditions.

Protection cap

Color	Code
Black	R0626641952



- Material: polypropylene PP.
- Packaging: 24 pieces.

Articulated Feet Gripper

in reinforced polypropylene

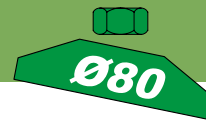

Part. R0626

Spindle in stainless steel		Spindle type		Code		Fmax. N
M12	A (mm)	H (mm)	2b	mm	feet supplied without cap*	↓
M12	85	55	2b	14	641402	10000

Item code for order = Part. + Code

- * = Feet are supplied without protection caps. Caps have to be ordered separately, indicating selected colour.
- Base material: reinforced polypropylene with integrated anti-slip in thermoplastic rubber grey (70 Shore).
- The sealing of the internal structure guarantees a better hygiene.
- Feet can be fixed to the floor.
- Packaging: 24 pieces.
- On request different length.
- Fmax. = maximum applicable load in static conditions.

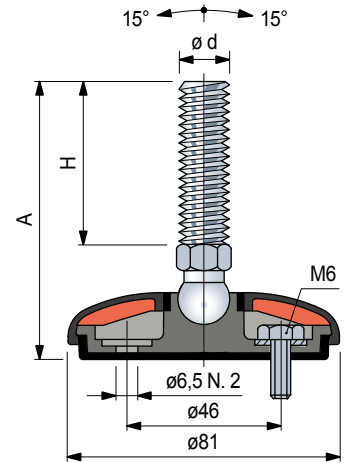

Protection cap

Color	Code
Black	R0626641952



- Material: polypropylene PP.
- Packaging: 24 pieces.

Part. R0627

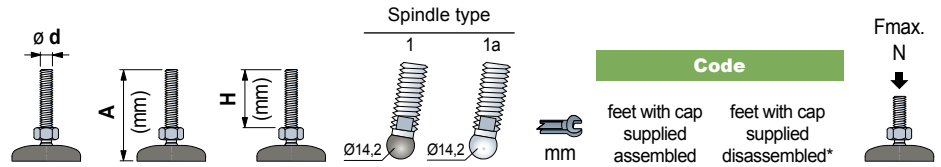

Spindle in stainless steel						Code		Fmax. N
M16	100	64	-	1a	13	feet with cap supplied assembled	feet with cap supplied disassembled*	
							115	81
	160	124	-	1a	13	642132	647352	
	185	151	-	1a	13	642142	647362	
M20	120	84	-	1a	16	642152	647372	
	185	149	-	1a	16	642162	647382	

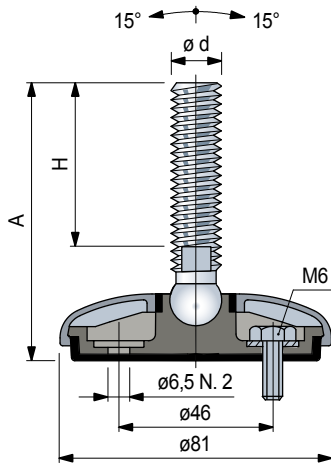

Item code for order = Part. + Code

- * = Feet can be fixed to the floor.
- Protection cap material: stainless steel AISI 304.
- Base material: reinforced polypropylene with integrated anti-slip in thermoplastic rubber grey (70 Shore).
- The sealing of the internal structure guarantees a better hygiene.
- Note: for spindles type 1 ball in reinforced polyamide.
- Packaging: 12 pieces.
- On request different length.
- Fmax. = maximum applicable load in static conditions.

Articulated Feet Gripper

in stainless steel

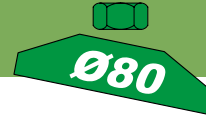

Part. R0627

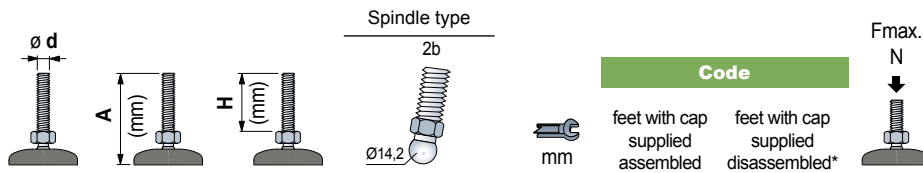

Spindle in stainless steel

M12	85	55	2b	14	641982	647302	10000
-----	----	----	----	----	--------	--------	-------

Item code for order = Part. + Code

* = Feet can be fixed to the floor.

- Protection cap material: stainless steel AISI 304.
- Base material: reinforced polypropylene with integrated anti-slip in thermoplastic rubber grey (70 Shore).
- The sealing of the internal structure guarantees a better hygiene.
- Note: for spindles type 1 ball in reinforced polyamide.
- Packaging: 12 pieces.
- On request different length.
- $F_{max.}$ = maximum applicable load in static conditions.

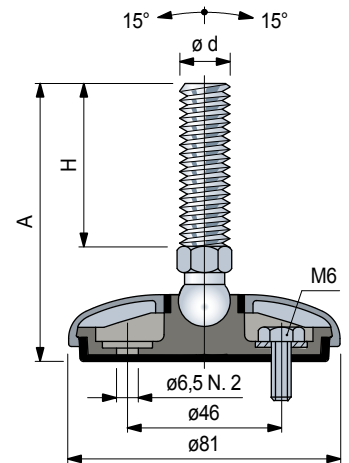

Part. R0622

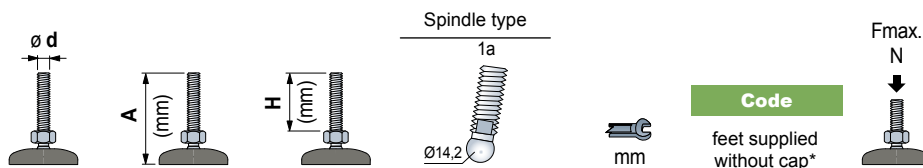

Spindle in stainless steel					
					Code
M16	105	64	1a	13	643552
	120	81	1a	13	643562
	165	124	1a	13	643572
	190	151	1a	13	643582
M20	125	84	1a	16	643592
	190	149	1a	16	643602

19500

Spindle in zinc plated steel					
					Code
M16	100	61	1a	13	643632
	155	116	1a	13	643652
	190	151	1a	13	643662
M20	190	150	1a	16	643682

19500

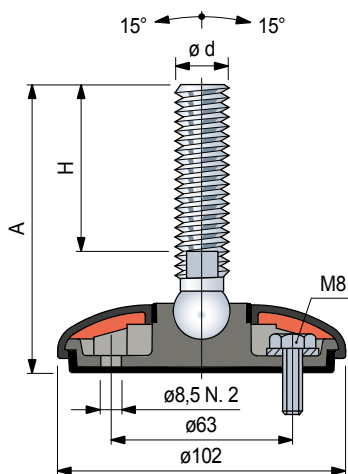

Item code for order = Part. + Code

- * = Feet are supplied without protection caps. Caps have to be ordered separately, indicating selected colour.
- Base material: reinforced polypropylene with integrated anti-slip in thermoplastic rubber grey (70 Shore).
- The sealing of the internal structure guarantees a better hygiene.
- Feet can be fixed to the floor.
- Packaging: 12 pieces.
- On request different length.
- Fmax. = maximum applicable load in static conditions.

Protection cap

Color	Code
Black	R0622639412



- Material: polypropylene PP.
- Packaging: 24 pieces.

Articulated Feet Gripper

in reinforced polypropylene

Ø100

REXNORD

Part. **R0622**

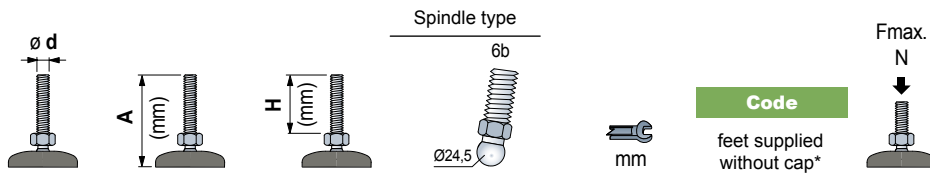

Spindle in stainless steel						
M16	150	109	6b	24	637272	19500
	185	144	6b	24	637282	

Spindle in zinc plated steel						
M16	195	154	6b	24	637372	19500

Item code for order = Part. + Code

- * = Feet are supplied without protection caps. Caps have to be ordered separately, indicating selected colour.
- Base material: reinforced polypropylene with integrated anti-slip in thermoplastic rubber grey (70 Shore).
- The sealing of the internal structure guarantees a better hygiene.
- Feet can be fixed to the floor.
- Packaging: 12 pieces.
- On request different length.
- Fmax. = maximum applicable load in static conditions.

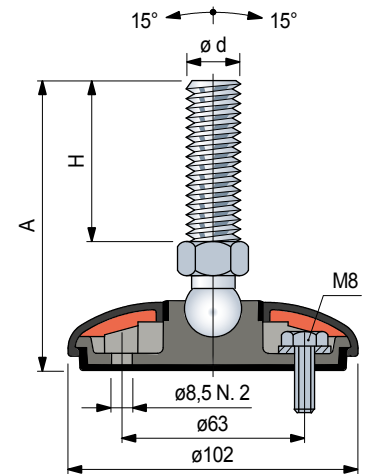

Protection cap

Color	Code
Black	R0622639412



- Material: polypropylene PP.
- Packaging: 12 pieces.

Part. R0623

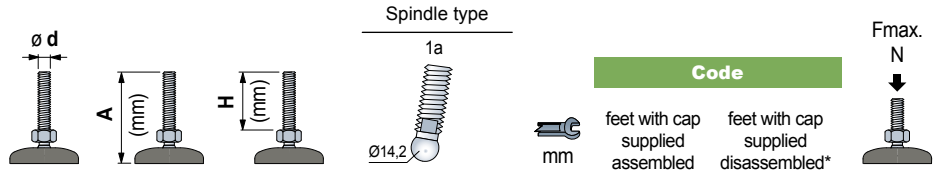

Spindle in stainless steel						
M16	105	64	1a	13	643732	647412
	120	81	1a	13	643742	647442
	165	124	1a	13	643752	647472
	190	151	1a	13	643762	647502
M20	125	84	1a	16	643772	647552
	190	149	1a	16	643782	647582

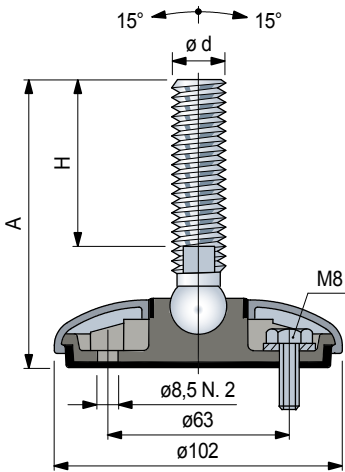

Item code for order = Part. + Code

- * = Feet can be fixed to the floor.
- Protection cap material: stainless steel AISI 304.
- Base material: reinforced polypropylene with integrated anti-slip in thermoplastic rubber grey (70 Shore).
- The sealing of the internal structure guarantees a better hygiene.
- Note: for spindles type 1 ball in reinforced polyamide.
- Packaging: 12 pieces.
- On request different length.
- Fmax. = maximum applicable load in static conditions.

Articulated Feet Gripper

in stainless steel

Ø100

REXNORD

Part. **R0623**

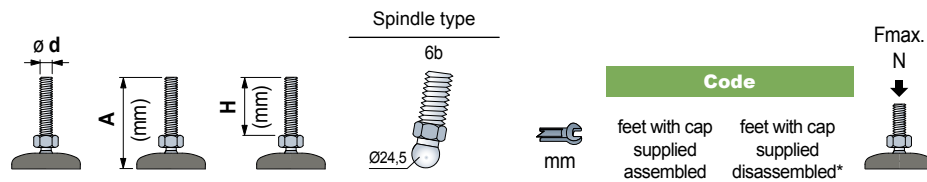

Spindle in stainless steel						
M16	150	109	6b	24	637522	647452
	185	144	6b	24	637532	647482
	220	179	6b	24	637582	647622
						19500

Item code for order = Part. + Code

- * = Feet can be fixed to the floor.
- Protection cap material: stainless steel AISI 304.
- Base material: reinforced polypropylene with integrated anti-slip in thermoplastic rubber grey (70 Shore).
- The sealing of the internal structure guarantees a better hygiene.
- Note: for spindles type 1 ball in reinforced polyamide.
- Packaging: 12 pieces.
- On request different length.
- Fmax. = maximum applicable load in static conditions.

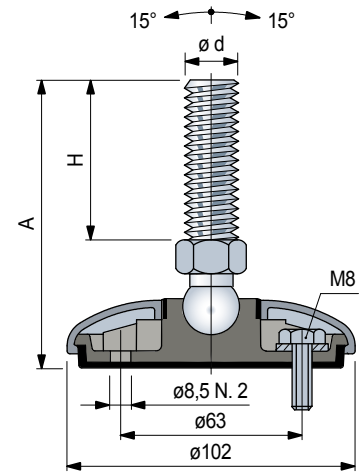

Part. R0628

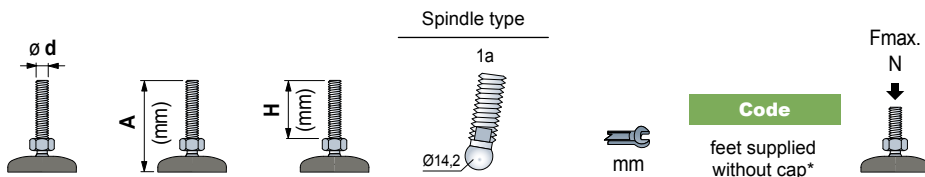

Spindle in stainless steel					Code	feet supplied without cap*	Fmax. N
M16	110	64	1a	13	643812	22000	
	125	81	1a	13	643822		
	170	124	1a	13	643832		
M20	195	151	1a	13	643842		
	130	84	1a	16	643852		
	195	149	1a	16	643862		

Spindle in zinc plated steel					Code	feet supplied without cap*	Fmax. N
M16	105	61	1a	13	643892	22000	
	160	116	1a	13	643912		
	195	151	1a	13	643922		
M20	195	150	1a	16	643942		

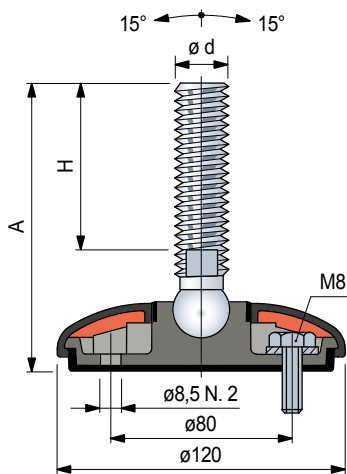

Item code for order = Part. + Code

- * = Feet are supplied without protection caps. Caps have to be ordered separately, indicating selected colour.
- Base material: reinforced polypropylene with integrated anti-slip in thermoplastic rubber grey (70 Shore).
- The sealing of the internal structure guarantees a better hygiene.
- Feet can be fixed to the floor.
- Packaging: 12 pieces.
- On request different length.
- Fmax. = maximum applicable load in static conditions.

Protection cap

Color	Code
Black	R0628643102



- Material: polypropylene PP.
- Packaging: 12 pieces.

Articulated Feet Gripper

in reinforced polypropylene

Ø120

REXNORD

Part. **R0628**

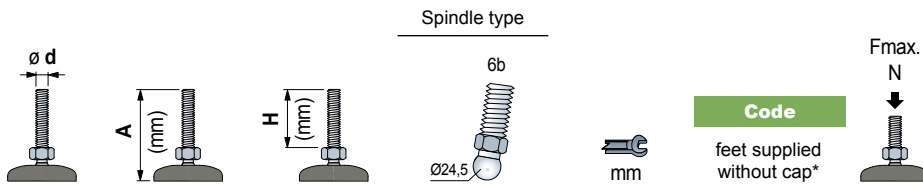

Spindle in stainless steel

	A (mm)	H (mm)	Spindle type	mm	Code	Fmax. N
M16	155	109	6b	24	642462	22000
	190	144	6b	24	642482	
M20	225	179	6b	24	642582	

Spindle in zinc plated steel

M16	200	154	6b	24	642662	22000
-----	-----	-----	----	----	--------	-------

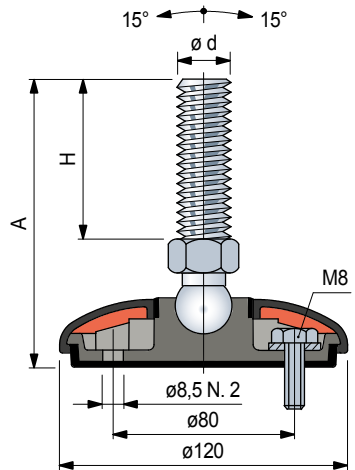

Protection cap

Color	Code
Black	R0628643102



- Material: polypropylene PP.
- Packaging: 12 pieces.

Item code for order = Part. + Code

* = Feet are supplied without protection caps. Caps have to be ordered separately, indicating selected colour.

- Base material: reinforced polypropylene with integrated anti-slip in thermoplastic rubber grey (70 Shore).
- The sealing of the internal structure guarantees a better hygiene.
- Feet can be fixed to the floor.
- Packaging: 12 pieces.
- On request different length.
- Fmax. = maximum applicable load in static conditions.

Part. R0629

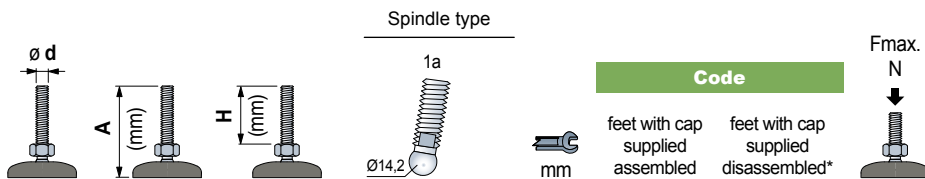

Spindle in stainless steel					Code		Fmax. N ↓ 22000
				feet with cap supplied assembled	feet with cap supplied disassembled*		
M16	110	64	1a	13	643992	647652	
	125	81	1a	13	644002	647682	
	170	124	1a	13	644012	647712	
M20	195	151	1a	13	644022	647742	
	130	84	1a	16	644032	647792	
	195	149	1a	16	644042	647822	

Item code for order = Part. + Code

* = Feet can be fixed to the floor.

- Base material: reinforced polypropylene with integrated anti-slip in thermoplastic rubber grey (70 Shore).
- The sealing of the internal structure guarantees a better hygiene.
- Feet can be fixed to the floor.
- Packaging: 12 pieces.
- On request different length.
- Fmax. = maximum applicable load in static conditions.

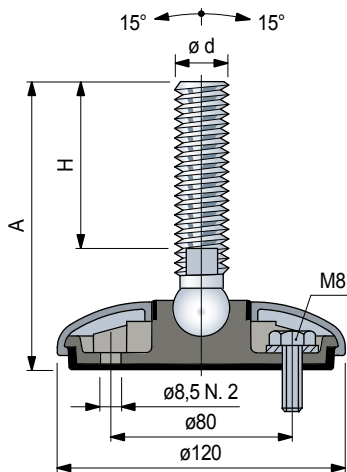

Articulated Feet Gripper

in stainless steel

Ø120

REXNORD

Part. **R0629**

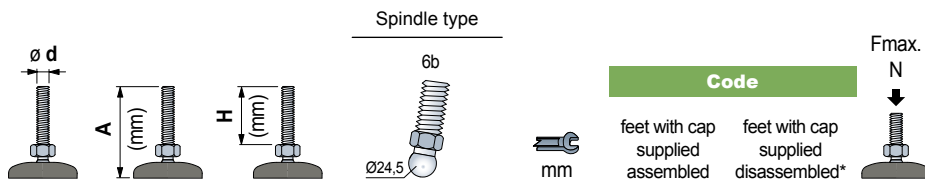

Spindle in stainless steel							
			Spindle type		Code		
					feet with cap supplied assembled	feet with cap supplied disassembled*	
M16	155	109	6b	24	642302	647692	22000
	190	144	6b	24	642322	647722	
M24	225	179	6b	24	642422	647862	

Item code for order = Part. + Code

- * = Feet can be fixed to the floor.
- Base material: reinforced polypropylene with integrated anti-slip in thermoplastic rubber grey (70 Shore).
- The sealing of the internal structure guarantees a better hygiene.
- Feet can be fixed to the floor.
- Packaging: 12 pieces.
- On request different length.
- Fmax. = maximum applicable load in static conditions.

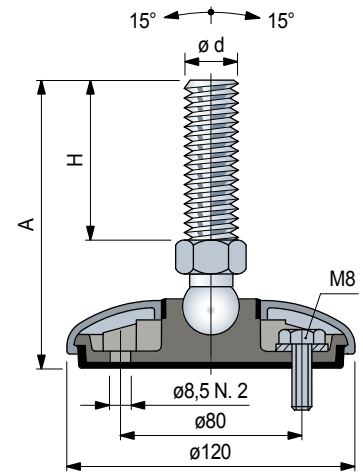

Part. R0349 4 holes



Part. R0349 4 holes

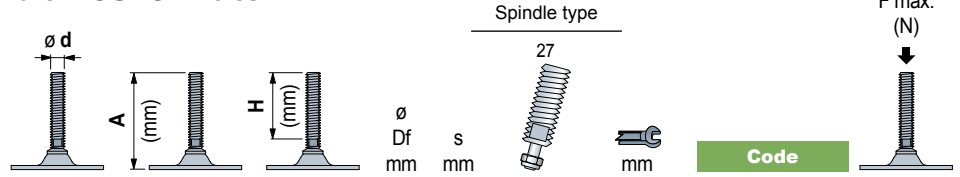

Feet in stainless steel								Code	F max. (N)	
M16	180	140	9	3	27	13	682721N1			6000
M20	180	140	9	3	27	17	68165N1			
M30	165	125	9	3	27	24	63757N1			
	225	180	9	3	27	24	682741N1			

Feet in zinc plated steel								Code	F max. (N)	
M20	175	140	9	4	27	17	65634N1			10000
M24	220	175	9	4	27	19	65054N1			
M30	165	125	9	4	27	24	65644N1			
	220	180	9	4	27	24	682711N1			

Item code for order = Part. + Code

- Packaging: 8 pieces.
- On request different length.
- Fmax. = maximum applicable load in static conditions.

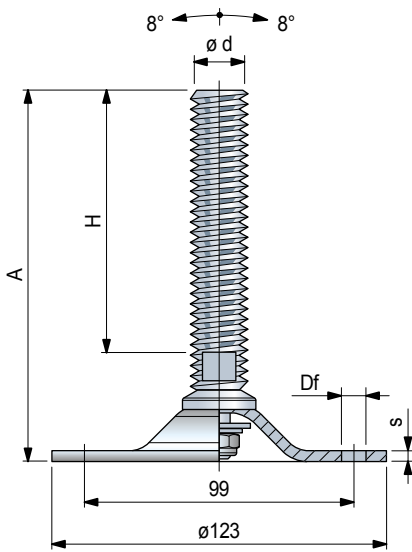

Articulated feet

in painted steel

Ø160

REXNORD

Part. **R0408**

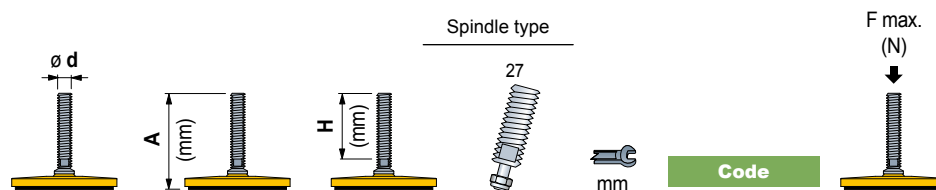

Spindle in stainless steel						
M24	220	175	27	19	678851N1	50000
M16	180	140	27	13	678831N1	
M20	180	140	27	17	678841N1	
M30	165	125	27	24	678861N1	
	225	180	27	24	678881N1	

Spindle in zinc plated steel						
M20	175	140	27	17	678771N1	
M24	220	175	27	19	678801N1	
M30	165	125	27	24	678811N1	
	220	180	27	24	678821N1	

Item code for order = Part. + Code

- Material: footplate in painted steel yellow. Anti-slip in NBR rubber black (70 Shore).
- Packaging: 4 pieces.
- On request different length.
- Fmax. = maximum applicable load in static conditions.

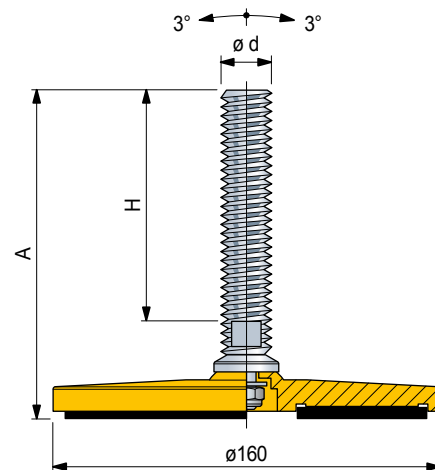

Part. **R0747**

Part. **R0748**

Part. **R0749**

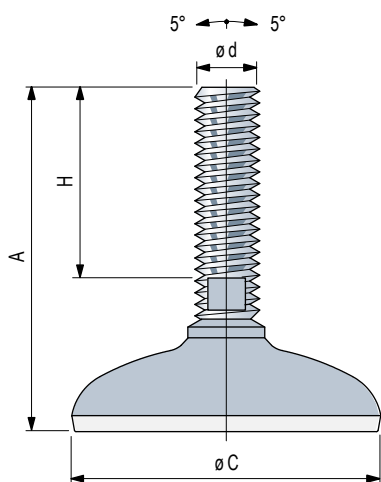

Part. **R0747**

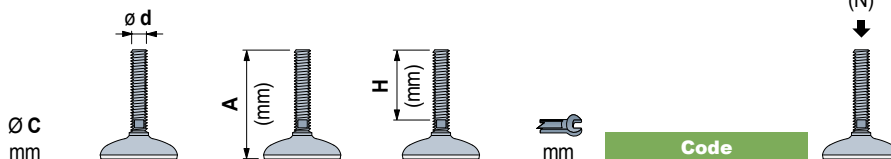

Feet in stainless steel						
	M16	182	136	13	602013	25000
	M20	187	139	16	602023	
	M30	215	165	27	620803	

Part. **R0748**

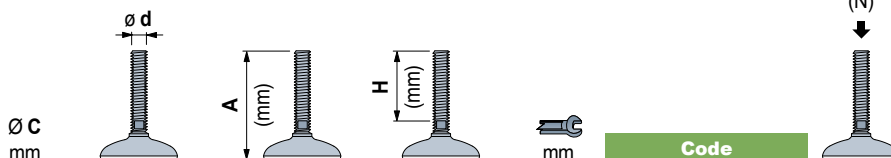

Feet in stainless steel						
	M16	185	136	13	602053	25000
	M20	190	139	16	602063	
	M24	220	167	19	602073	
	M30	218	165	27	620823	

Part. **R0749**

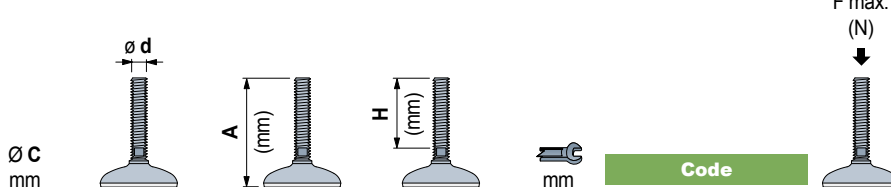

Feet in stainless steel						
	M16	190	136	13	602093	25000
	M20	195	139	16	602103	
	M30	223	165	27	620843	
		250	200	27	616433	

Item code for order = Part. + Code

- Material:
Spindle in austenitic stainless steel.
Footplate in austenitic stainless steel.
Anti-slip in vulcanized NBR rubber (grey), 75 Shore;
Part R0749616433 - R0749628033 anti-slip in vulcanized NBR rubber NBR (black), 95 Shore.
- Packaging: 4 pieces.
- On request different length.
- Fmax. = maximum applicable load in static conditions.

Articulated feet in stainless steel

Part. R0747F

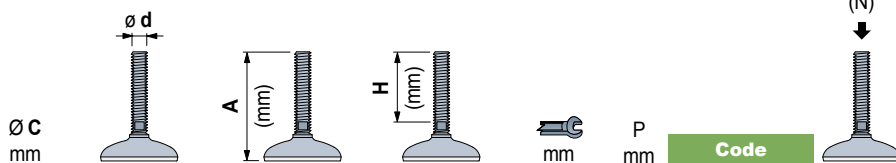

Feet in stainless steel

	M16	182	136	13	55	616063	25000
	M20	187	139	16	55	616073	
	M30	215	165	27	55	620863	

Part. R0748F

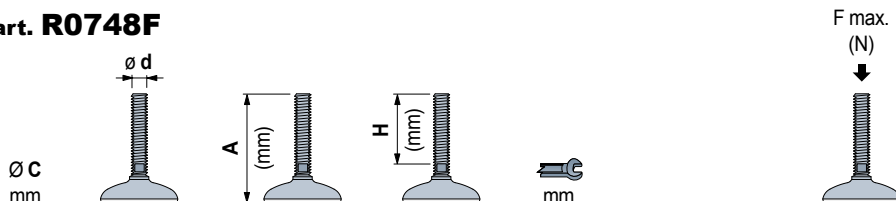

Feet in stainless steel

	M16	185	136	13	67	616103	25000
	M20	190	139	16	67	616113	
	M24	220	167	19	67	616123	
	M30	218	165	27	67	620883	

Item code for order = Part. + Code

- Material:
Spindle in austenitic stainless steel.
Footplate in austenitic stainless steel.
Anti-slip in vulcanized NBR rubber (grey), 75 Shore.
- Packaging: 4 pieces.
- On request different length.
- Fmax. = maximum applicable load in static conditions.

Part. R0747F

Part. R0748F

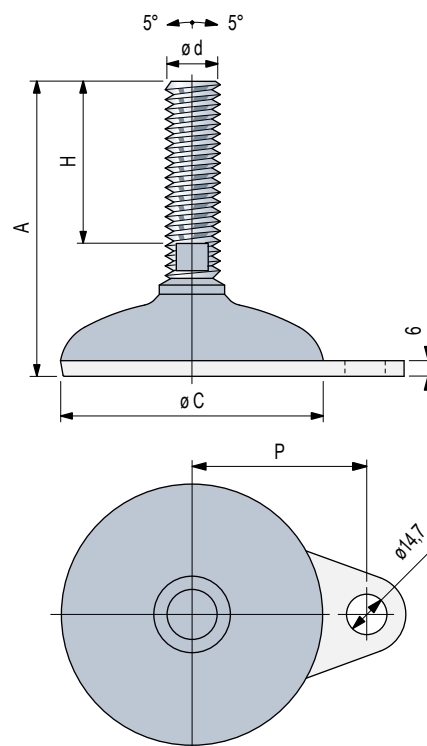

Part. R0750S

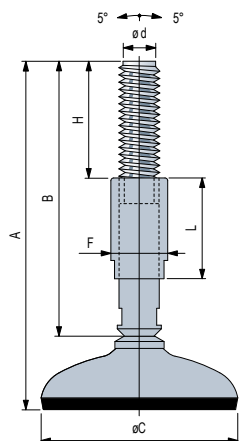

Part. R0750S

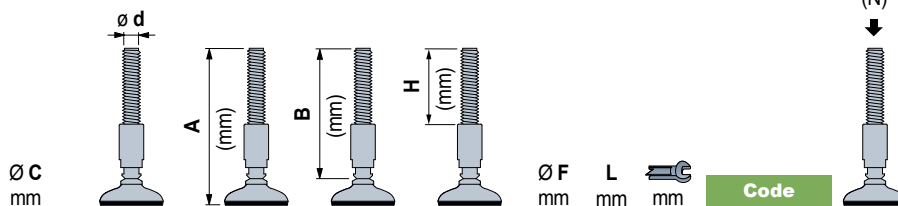

Feet in stainless steel									
	M16	200	165	100	23	55	13	Code	25000

Item code for order = Part. + Code

- Material:
Spindle and threaded bushing in austenitic stainless steel.
Footplate in austenitic stainless steel.
Anti-slip in vulcanized NBR rubber (black), 95 Shore.
- Packaging: 4 pieces.
- Fmax. = maximum applicable load in static conditions.

Part. R0750SF

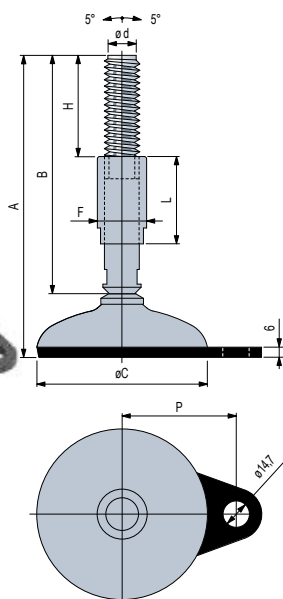

Part. R0750SF

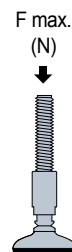
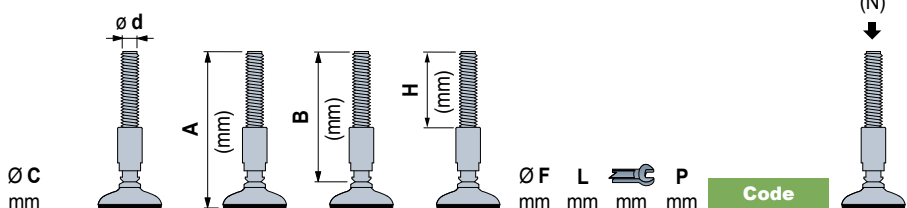

Feet in stainless steel										
	M16	200	165	100	23	55	13	55	Code	25000

Item code for order = Part. + Code

- Material:
Spindle and threaded bushing in austenitic stainless steel.
Footplate in austenitic stainless steel.
Anti-slip in vulcanized NBR rubber (black), 95 Shore.
- Packaging: 4 pieces.
- Fmax. = maximum applicable load in static conditions.

Fixed feet

in painted steel

Ø100

REXNORD

Part. **R0406**

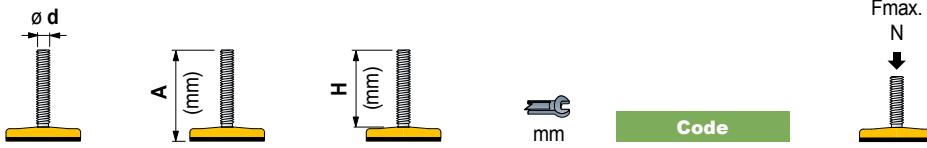

Feet in zinc plated steel

	A	H	mm	Code	Fmax. N
M16	157	127	10	66614	50000



Item code for order = Part. + Code

- Material: footplate in painted steel yellow. Anti-slip in NBR rubber black (80 Shore).
- Packaging: 4 pieces.
- On request different length.
- Fmax. = maximum applicable load in static conditions.

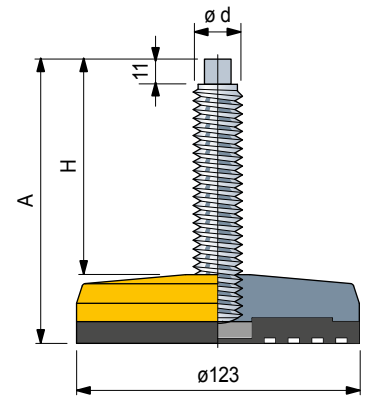

Part. R0180

Tube dimensions

Outside dia. mm	Thickness mm	Inside dia. mm	Thread D	D1 mm	D2 mm	H mm	L mm	M mm	Code	Fmax. N
48,3	1 1/2	45,3	M16	48	45,5	10	52	24	63081	5000
54	-	50	M16	54	50,8	10	62	24	647081	5000
60,3	2	56,3	M16	60	57	10	62	24	65174	5000

- Material: bushing in reinforced polyamid PA FV (black). Threaded insert in nickel plated brass.
- Packaging: 12 pieces.
- Fmax. = maximum applicable load in static conditions.

Tube dimensions B.S.I.

Outside dia. Inch	Thickness mm	Inside dia. mm	Thread D	D1 mm	D2 mm	H mm	L mm	M mm	Code	Fmax. N
2"	50,8	47,5	M16	50	48,4	10	56	24	668191	5000

Item code for order = Part. + Code

- Material: bushing in reinforced polyamid PA FV (black). Threaded insert in nickel plated brass.
- Packaging: 12 pieces.
- Fmax. = maximum applicable load in static conditions.

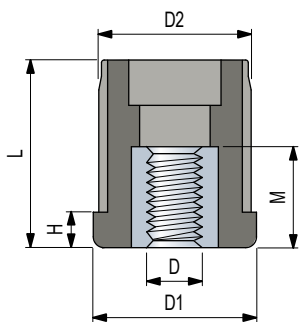

Assembly

Pressure fitted.
Interference fit.



Threaded bushings

for square tubes

Part. R0224

Metric tube dimensions

Outside dia. mm	Thickness mm	Inside dia. mm	Thread D	D1 mm	D2 mm	H mm	L mm	M mm	Code	Fmax. N ↓	
∅ 40	1,5	37	M12	40	37,5	8	43	19	63882	5000	
			M16	40	37,5	8	43	24	63902	5000	
	2	36	M16	40	36,5	8	43	24	66533	5000	
			M20	40	36,5	8	43	30	64455	8000	
∅ 50	1,5	47	M16	50	47,8	10	55	24	68607	5000	
			M20	50	47,5	10	55	30	68883	8000	
			3/8"-16	50	47,8	10	55	19	692781	5000	
			1/2"-13	50	47,8	10	55	19	692791	5000	
	2	46	45	5/8"-11	50	47,8	10	55	24	692801	5000
				3/4"-10	50	47,8	10	55	30	692811	8000
				M16	50	47	10	55	24	617632	5000
				M20	50	47	10	55	30	617642	8000
2,5	45	45	M14	50	45,6	10	55	24	695411	5000	
			M16	50	45,5	10	55	24	63051	5000	
			M20	50	45,5	10	55	30	63001	8000	

- Material: bushing in reinforced polyamid PA FV (black). Threaded insert in nickel plated brass.
- Packaging: 12 pieces.
- Fmax. = maximum applicable load in static conditions.

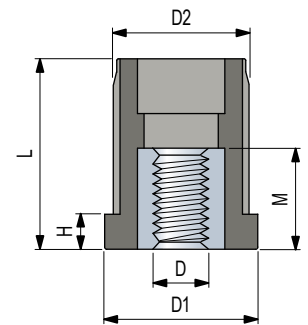

Tube dimensions B.S.I.

Outside dia. Inch	Thickness mm	Inside dia. mm	Thread D	D1 mm	D2 mm	H mm	L mm	M mm	Code	Fmax. N ↓		
∅ 2"	50,8	0,109"	2,77	45,3	3/4" 10	50	45,6	10	55	30	59241	8000

Item code for order = Part. + Code

- Material: bushing in reinforced polyamid PA FV (black). Threaded insert in nickel plated brass.
- Packaging: 12 pieces.
- Fmax. = maximum applicable load in static conditions.

Assembly

Pressure fitted.
Interference fit.



SQUARE FLANGE BEARING**Pag. B04 - B13****OVAL FLANGE BEARING****Pag. B14 - B21****PILLOW BLOCK BEARING****Pag. B22 - B25****COMPACT PILLOW BLOCK BEARING****Pag. B26 - B27**

SIDE FLANGE BEARING

Pag. B28 - B35



TAKE-UP BEARING

Pag. B36 - B37



ROUND FLANGE BEARING

Pag. B38 - B43



TECHNICAL INFORMATIONS

Technical Informations see Pag. B45 - B59

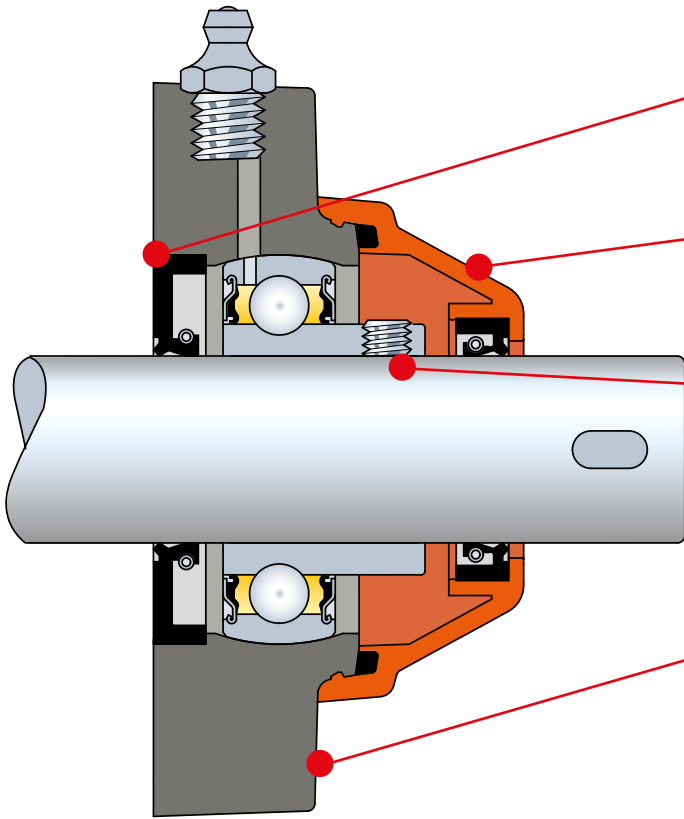

Waterproof housing

The waterproof sealing system guarantees protection of the bearing from the external environment

Inspectable bearing

The clip-on protection cover can be removed for bearing inspection

Locking by grub screws

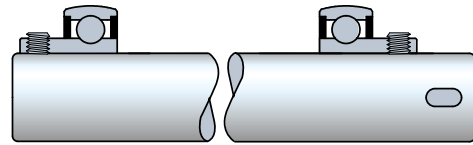

ISO dimensions

The overall dimensions can be interchanged with the corresponding cast iron type bearings

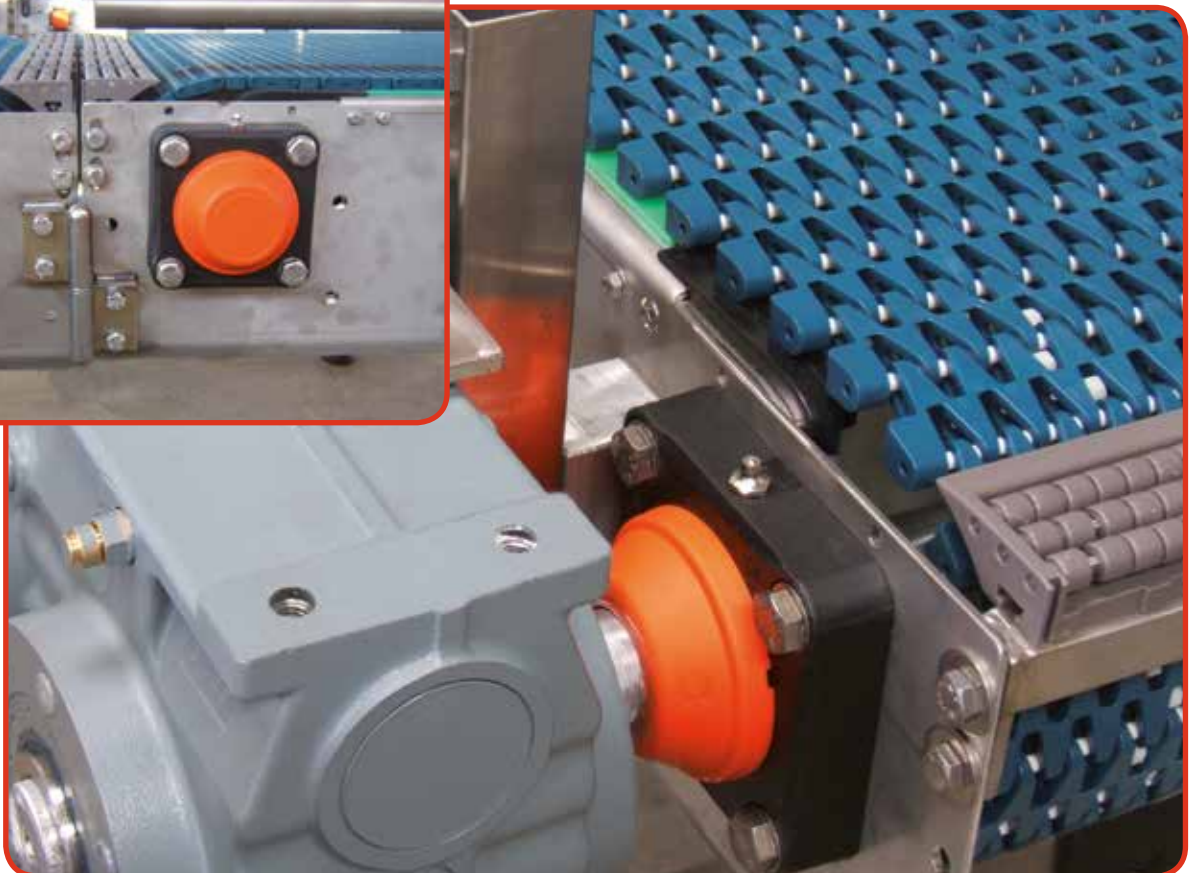
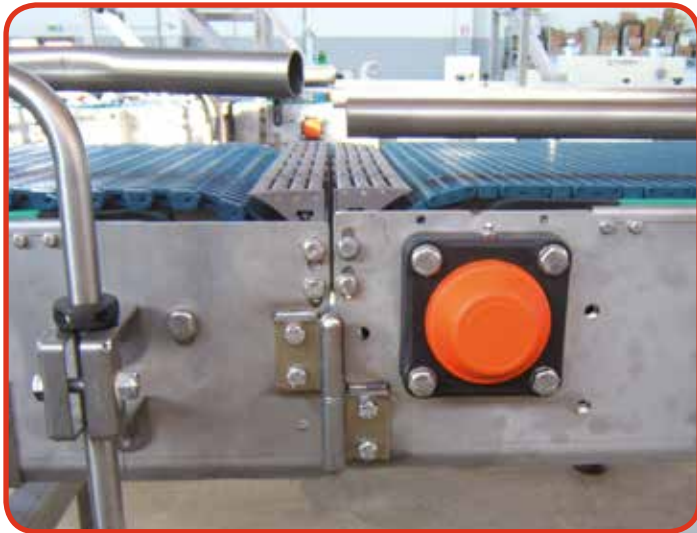

- Overall dimensions of self-aligning bearings are in accordance with ISO 3228 standards
- All self-aligning bearings are interchangeable with their correspondent cast iron versions

ISO
3228

ISO dimensions

- Self-aligning bearings are equipped with stainless steel AISI 304/316 bushes to reinforce mounting holes
- The reinforcing bushings avoid damages to the plastic flange during screw tightening



Fixing bushes

- Only best quality glass fibre reinforced polyamide PA FV/polypropylene PP FV thermoplastic resins are used for the self-aligning housings
- The resins used guarantee high resistance to oxidation and corrosion and at the same time equal the strength offered by cast iron housings. They offer a better resistance to impact
- Polyamide PA FV resins offer maximum heat and mechanical resistance
- Polypropylene PP FV resins offer maximum resistance to chemical agents



Thermoplastic resins

- A system of waterproof seals protects the bearing from external environment
- Protection from dust, humidity, washouts, chemical agents
- The clip-on protection cover allows inspection of the bearing

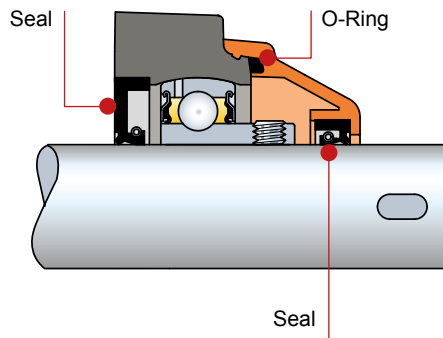

Waterproof housing

- Self-aligning bearings are equipped with ball bearings featuring multipurpose sealing systems.
- **A - D** - Superagriseal unit. The system consists of a metallic ring fitted with a low friction rubber sealing lip
- **B** - Superagriseal unit + centrifuging ring. The system is further equipped with a metallic protection ring providing a centrifugal sealing action.
- **C steel** - Superagriseal unit + rubberised centrifuging ring. This system is used in stainless steel bearings. The upper lip of the centrifuging ring together with the grease trapped between the base seal and the ring itself guarantees maximum sealing capacity.

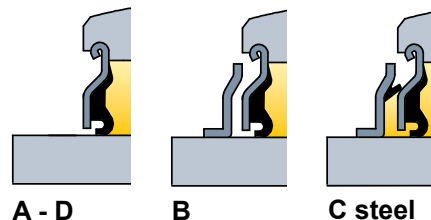

Bearing seals

- Waterproof self-aligning bearings feature seals for the protection against external environment
- Viton rubber seals ensure maximum resistance to chemical agents

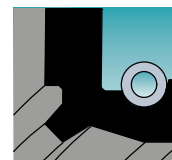

Support seals

- All bearings are self-aligning, capable of compensating misalignments up to 2°

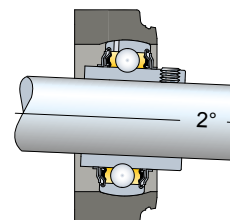

Misalignment

Square flange bearing units

UCF/C - SUCF/C - HCF/C - SHCF/C



Waterproof housing

Grub screws or eccentric collar shaft locking

PA FV polyamide housing

High mechanical and heat resistance. Proof to dust, humidity, washouts, steam, average aggressive chemical agents.

PP FV polypropylene housing

Proof to highly aggressive chemical agents. Inferior loading ability.

Solid flange bearings

They differ from standard flange versions for their closed surface structure, ideal for sanitation.

Material

PA FV polyamide housing

- Housing in reinforced polyamide PA FV resin (black)
- Protection cover in polypropylene PP (orange)
- Seal and O-Ring in NBR rubber (black)
- Ball type nickel plated brass greasing nipple
- Reinforcing bushings on mounting holes and washers in stainless steel AISI 304

Continuous operating temperature

in air: - 20 to + 60°C.

Maximum allowed misalignment: 2°.

Bearing



- Type A (grub screws shaft locking)
- Type D (eccentric collar shaft locking)
- Chrome alloy steel
- Supergriseal unit
- Prelubricated with lithium / calcium grease
- Can be relubricated.

• Series UCF/C • Type A Grub screws shaft locking

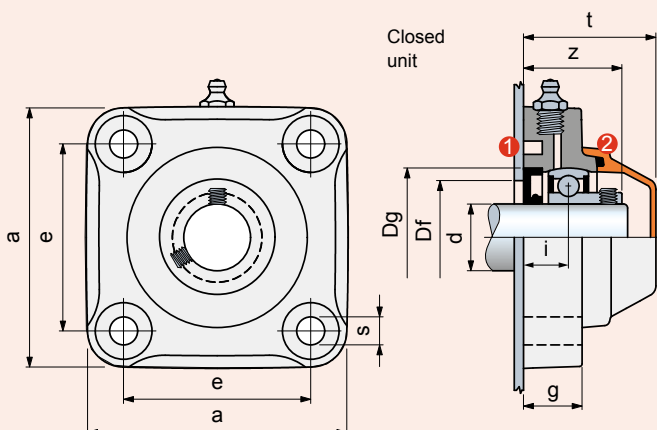

• Series HCF/C • Type D Eccentric collar shaft locking

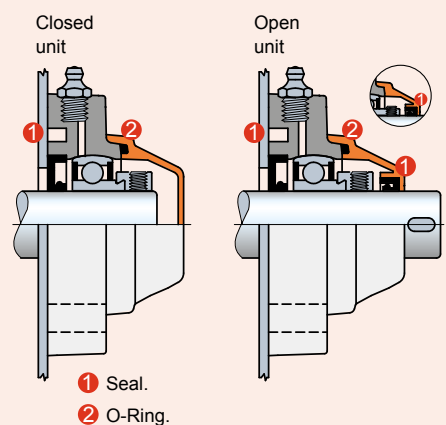

UCF/C - SUCF/C - HCF/C - SHCF/C

dia. d mm	Series	Housing material		Dimensions in mm										Bore in frame ²⁾ Df		Bearing	Weight Kg	Spare parts Cover orange	
		Polyamide PA FV Standard Flange (black) Cover (orange)	Code	e	a	s	g	i	z	t	Dg	max.	min.	Code	Code				
Grub screws shaft locking • Closed unit																			
25	UCF 205 C	64573		70	98	11	22,5	16,8	36,3	49,5	52	50	45	Type A	0,40	681952			
30	UCF 206 C	63112		83	110	11	26	20	42	56	62	60	50	Type A	0,56	63154			
35	UCF 207 C	64018		92	120	11	26	19,5	43	59	72	70	55	Type A	0,72	682022			
35*	SUCF 207 C	680522 ¹⁾		83	110	11	26	19,5	43	61	72	70	55	Type A	0,67	63539			
40	UCF 208 C	68916		102	131	11	30	22	47	65,5	80	78	65	Type A	0,95	63539			
40*	SUCF 208 C	61819		83	110	11	26	19	44	66	80	78	65	Type A	0,88	600882			
Grub screws shaft locking • Open unit																			
25	UCF 205 C	64623		70	98	11	22,5	16,8	36,3	49,5	52	50	45	Type A	0,40	681972			
30	UCF 206 C	63172		83	110	11	26	20	42	56	62	60	50	Type A	0,56	69965			
35	UCF 207 C	64028		92	120	11	26	19,5	43	59	72	70	55	Type A	0,72	682032			
35*	SUCF 207 C	680582 ¹⁾		83	110	11	26	19,5	43	61	72	70	55	Type A	0,67	615692			
40	UCF 208 C	68926		102	131	11	30	22	47	65,5	80	78	65	Type A	0,95	63549			
40*	SUCF 208 C	61829		83	110	11	26	19	44	66	80	78	65	Type A	0,88	600892			
Eccentric collar shaft locking • Closed unit																			
40*	SHCF 208 C	62439		83	110	11	26	19	51,7	66	80	78	65	Type D	1,07	600882			
Eccentric collar shaft locking • Open unit																			
40*	SHCF 208 C	62449		83	110	11	26	19	51,7	66	80	78	65	Type D	1,07	600892			

* = Version with special fixing holes.

¹⁾ = Solid flange.

²⁾ = Dimensions Df max / Df min must be respected to ensure positive retention of the seals and to allow air bleeding during lubrication.

Packaging: 4 pieces.

Square flange bearing units

UCF/CL - SUCF/CL - HCF/CL - SHCF/CL

LIFE LUBRICATED



Dry use recommended



Life lubricated

The ball-bearings are pre-lubricated with a special grease keeping the bearing for its whole life. No need for re-lubrication (see page B56 to calculate the grease life)

Grub screws or eccentric collar shaft locking

PA FV polyamide housing

High mechanical and heat resistance. Proof to dust, average aggressive chemical agents.

Solid flange bearings

They differ from standard flange versions for their closed surface structure, ideal for sanitation.

Material

PA FV polyamide housing

- Housing in reinforced polyamide PA FV resin (black)
- Protection cover in polypropylene PP (orange)
- Seal and O-Ring in NBR rubber (black)
- Reinforcing bushings on mounting holes and washers in stainless steel AISI 304.

Continuous operating temperature

in air: - 20 to + 60°C.

Maximum allowed misalignment: 2°.

Bearing



- Type A (grub screws shaft locking)
- Chrome alloy steel
- Superagriseal unit
- Prelubricated with lithium / calcium grease, no need for re-lubrication.

• Series UCF/CL • Type A Grub screws shaft locking

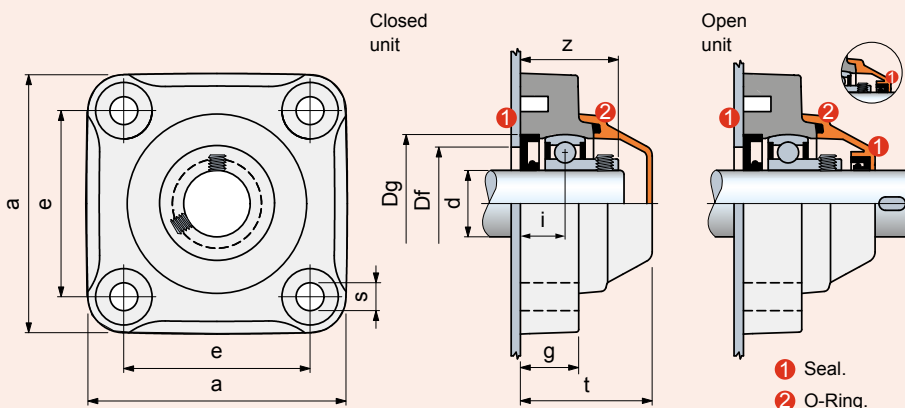

UCF/CL - SUCF/CL - HCF/CL - SHCF/CL

dia. d mm	Series	Housing material	Dimensions in mm										Bore in frame Df		Bearing	Weight Kg	Spare parts Cover orange
		Polyamide PA FV Standard Flange (black) Cover (orange)	e	a	s	g	i	z	t	Dg	max.	min.	Code				
Grub screws shaft locking • Closed unit																	
40*	SUCF 208 CL	61819L	83	110	11	26	19	44	66	80	78	65	Type A	0,88	600882		
Grub screws shaft locking • Open unit																	
40*	SUCF 208 CL	61829L	83	110	11	26	19	44	66	80	78	65	Type A	0,88	600892		
Eccentric collar shaft locking • Closed unit																	
40*	SHCF 208 CL	62439L	83	110	11	26	19	51,7	66	80	78	65	Type D	1,07	600882		
Eccentric collar shaft locking • Open unit																	
40*	SHCF 208 CL	62449L	83	110	11	26	19	51,7	66	80	78	65	Type D	1,07	600892		

* = Version with special fixing holes.
Packaging: 4 pieces.

Square flange bearing units

UCF - SUCF - HCF - SHCF



Accessories

- **Material**
PA FV polyamide housing
 - Housing in reinforced polyamide PA FV resin (black)
 - Ball type nickel plated brass greasing nipple
 - Reinforcing bushings on mounting holes and washers in stainless steel AISI 304.
- **Continuous operating temperature**
 in air: - 20 to + 60°C.
- **Maximum allowed misalignment:** 2°.
- **Bearing**
 - Type B (grub screws shaft locking, chrome alloy steel, Superagriseal unit plus centrifuging ring)
 - Type C (grub screws shaft locking, stainless steel AISI 420, Superagriseal unit plus rubberised centrifuging ring)
 - Type A (grub screws shaft locking, chrome alloy steel, Superagriseal unit)
 - Type D (eccentric collar shaft locking, chrome alloy steel, Superagriseal unit)
 - Prelubricated with lithium / calcium grease
 - Can be relubricated.

Grub screws or eccentric collar shaft locking

Version with bearing Type B

The double ring guarantees maximum protection against dust and non-corrosive substances.

Version with stainless steel bearing Type C

AISI 420 stainless steel bearing with 2 rubberised rings, provides excellent seal against humidity, steams, liquids, medium corrosive chemical agents. Maximum load ability is inferior.

Version with bearing Type A

The rubberised ring guarantees maximum protection against dusts.

Material

Polyamide PA FV guarantees maximum strength and high-temperature resistance.

Protection covers (accessories)

Closed cover

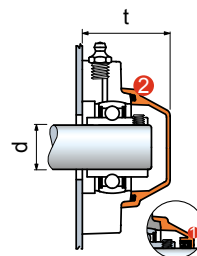

Dia 45/50 supplied without o-ring

Open cover

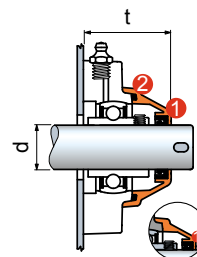

Dia 45/50 supplied without o-ring

- ① Seals.
- ② Seals O-Ring.

dia. d mm	Accessories Cover orange	t mm
	Code	
Closed cover supplied with seals		
25	681952	49,5
25*	681952	54
30	63154	56
35	682022	59
35* Standard	63154	54,6
40*	600882	66
Open cover supplied with seals		
25	681972	49,5
25*	681972	54
30	69965	56
35	682032	59
35* Solid	615692	61
40	63549	65,5

* = Version with special fixing holes.

• Series UCF • Type B
Grub screws shaft locking

• Series UCF • Type C
Grub screws shaft locking

• Series UCF • Type A
Grub screws shaft locking

• Series HCF • Type D
Eccentric collar shaft locking

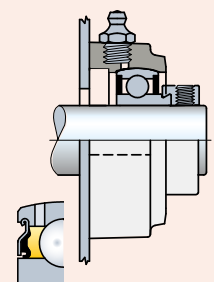
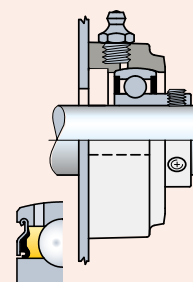
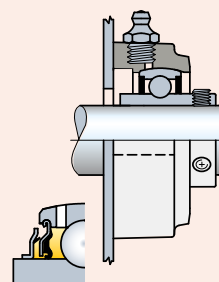
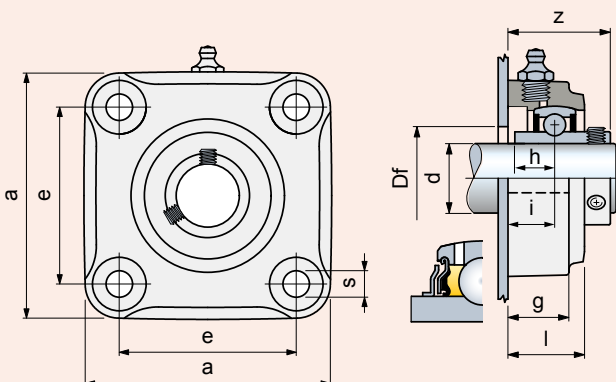

dia. d mm	Series	Housing material		Dimensions in mm								Bore in frame Df mm	Bearing	Weight Kg
		Polyamide PA FV Standard Flange (black)	Code	e	a	s	g	i	h	l	z			
Grub screws shaft locking • Version with bearing Type B														
25	UCF 205	64533		70	98	11	22,5	16,8	14,3	27,5	36,5	29	Type B	0,44
30	UCF 206	60722		83	110	11	26	20	15,9	32,5	42,2	34	Type B	0,57
35	UCF 207	64058		92	120	11	26	19,5	17,5	32	44,9	39	Type B	0,72
Grub screws shaft locking • Version with stainless steel bearing Type C														
25	UCF 205	646592		70	98	11	22,5	16,8	14,3	27,5	36,6	29	Type C	0,44
30	UCF 206	646602		83	110	11	26	20	15,9	32,5	42,2	34	Type C	0,57
Grub screws shaft locking • Version with bearing Type A														
25	UCF 205	656752		70	98	11	22,5	16,8	-	27,5	36,3	29	Type A	0,39
30	UCF 206	666442		83	110	11	26	20	-	32,5	42	34	Type A	0,54
35	UCF 207	666452		92	120	11	26	19,5	-	32	43	39	Type A	0,69
40	UCF 208	666462		102	131	11	30	22	-	36	47	44	Type A	0,92
40*	SUCF 208	681552		83	110	11	26	19	-	36	44	44	Type A	0,85
Eccentric collar shaft locking • Version with bearing Type D														
40*	SHCF 208	62349		83	110	11	26	19	-	36	51,7	44	Type D	1,04

Item code for order = B0000 + Code

* = Version with special fixing holes.

¹⁾ = Solid flange.

• = Solid flange 19,5.

Packaging: 4 pieces.

Square flange bearing units

UCFS/C - SUCFS/C - HCFS/C - SHCFS/C

- Austenitic stainless steel surface
- Waterproof housing
- Grub screws or eccentric collar shaft locking
- Solid flange
- Closed surface structure.



Material

- Housing in reinforced polyamide PA FV resin (black)
- Austenitic stainless steel surface
- Protection cover in polypropylene PP (orange)
- Seal and O-Ring in NBR rubber (black)
- Ball type nickel plated brass greasing nipple.

Continuous operating temperature

in air: - 20 to + 60°C.

Maximum allowed misalignment: 2°.

Bearing



- Type A (grub screws shaft locking)
- Type D (eccentric collar shaft locking)
- Chrome alloy steel
- Superagriseal unit
- Prelubricated with lithium / calcium grease
- Can be relubricated.

Series UCFS/C • Type A Grub screws shaft locking

Series HCFS/C • Type D Eccentric collar shaft locking

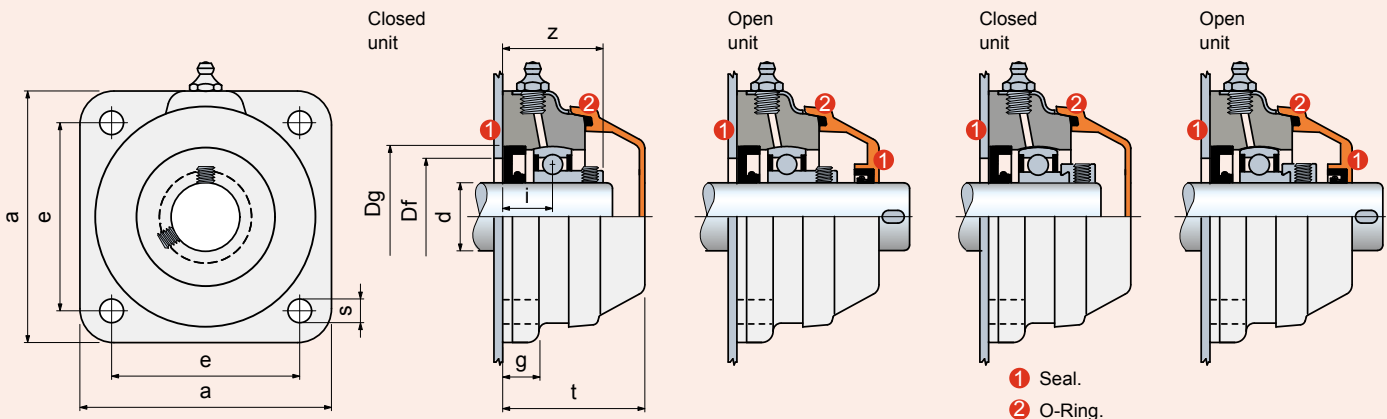

UCFS/C - SUCFS/C - HCFS/C - SHCFS/C

dia. d mm	Series	Housing material	Dimensions in mm									Bore in frame ¹⁾ Df		Bearing	Weight Kg	Spare parts Cover orange
		Polyamide PA FV with austenitic stainless steel surface Solid Flange Cover (orange)	e	a	s	g	i	z	t	Dg	max.	min.	Code			
Grub screws shaft locking • Closed unit																
30	UCFS 206 C	647613	83	111	10,5	15,9	22	44	65,8	62	60	50	Type A	0,73	63539	
35*	SUCFS 207 C	647623	83	111	10,5	15,9	22	45,5	65,8	72	70	55	Type A	0,84	63539	
40*	SUCFS 208 C	647633	83	111	10,5	15,9	22	47	65,8	80	78	65	Type A	0,94	63539	
Grub screws shaft locking • Open unit																
30	UCFS 206 C	647643	83	111	10,5	15,9	22	44	65,8	62	60	50	Type A	0,73	615682	
35*	SUCFS 207 C	647653	83	111	10,5	15,9	22	45,5	65,8	72	70	55	Type A	0,84	615692	
40*	SUCFS 208 C	647663	83	111	10,5	15,9	22	47	65,8	80	78	65	Type A	0,94	63549	
Eccentric collar shaft locking • Closed unit																
40*	SHCFS 208 C	647693	83	111	10,5	15,9	19	51,7	65,8	80	78	65	Type D	1,00	63539	
Eccentric collar shaft locking • Open unit																
40*	SHCFS 208 C	647723	83	111	10,5	15,9	19	51,7	65,8	80	78	65	Type D	1,00	63549	

* = Version with special fixing holes.

¹⁾ = Dimensions Df max / Df min must be respected to ensure positive retention of the seals and to allow air bleeding during lubrication.

Packaging: 4 pieces.

Square flange bearing units

F - SF



Waterproof housing

Shaft shoulders locking

High axial load capacity.

PA FV polyamide housing

High mechanical and heat resistance. Proof to dust, humidity, washouts, steam, average aggressive chemical agents.

■ **Material**

PA FV polyamide housing

- Housing in reinforced polyamide PA FV resin (black)
- Seal and O-Ring in NBR rubber (black)
- Ball type nickel plated brass greasing nipple
- Reinforcing bushings on mounting holes and washers in stainless steel AISI 304.

■ **Continuous operating temperature**

in air: - 20 to + 60°C.

■ **Maximum allowed misalignment: 2°.**

■ **Bearing**

- Type 1200 self aligning ball bearing
- Chrome alloy steel
- Supplied without grease
- To be prelubricated with lithium / calcium grease during first installation.

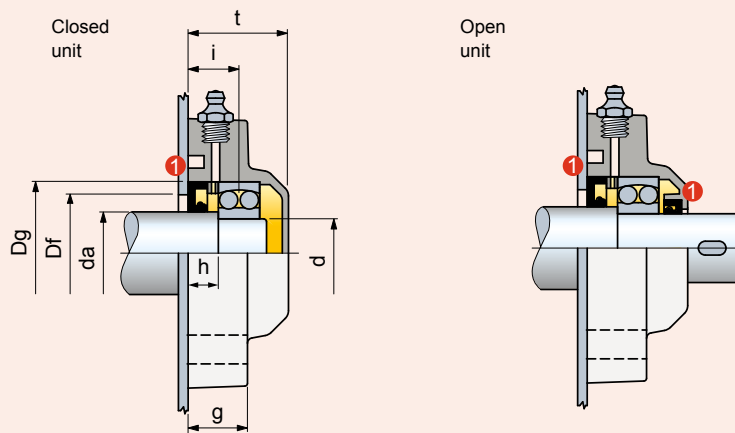
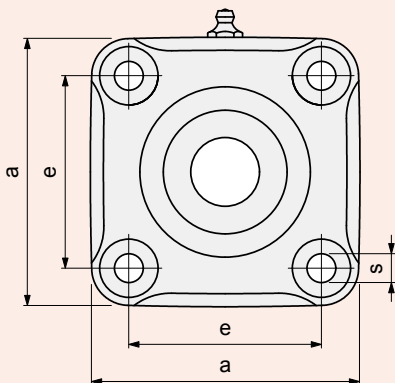

① Seal.

Shaft dia. da mm	Bearing dia. d mm	Series	Housing material		Dimensions in mm										Bore in frame ¹⁾ Df		Bearing	Weight Kg
			Polyamide PA FV Standard Flange (black)	Code	e	a	s	g	i	h	t	Dg	max.	min.				
Closed unit																		
30	25	F 1205	64433		70	98	11	22,5	18,5	11	36,5	52	50	47	Type 1200	0,36		
Open unit																		
30	25	F 1205	64483		70	98	11	22,5	18,5	11	36,5	52	50	47	Type 1200	0,36		

Item code for order = B0000 + Code
¹⁾ = Dimensions Df max / Df min must be respected to ensure positive retention of the seals and to allow air bleeding during lubrication.

Packaging: 6 pieces.

Oval flange bearing units

UCFLN/C - SUCFLN/C - HCFLN/C - SHCFLN/C



Waterproof housing

Grub screws or eccentric collar shaft locking

PA FV polyamide housing

High mechanical and heat resistance. Proof to dust, humidity, washouts, steam, average aggressive chemical agents.

Solid flange bearings

Closed surface structure, ideal for sanification.

Material

PA FV polyamide housing

- Housing in reinforced polyamide PA FV resin (black)
- Protection cover in polypropylene PP (orange)
- Seal and O-Ring in NBR rubber (black)
- Ball type nickel plated brass greasing nipple
- Reinforcing bushings on mounting holes and washers in stainless steel AISI 304

Continuous operating temperature

in air: - 20 to + 60°C.

Maximum allowed misalignment: 2°.

Bearing



- Type A (grub screws shaft locking)
- Chrome alloy steel
- Superagriseal unit
- Prelubricated with lithium / calcium grease
- Can be relubricated.

• Series UCFLN/C • Type A Grub screws shaft locking

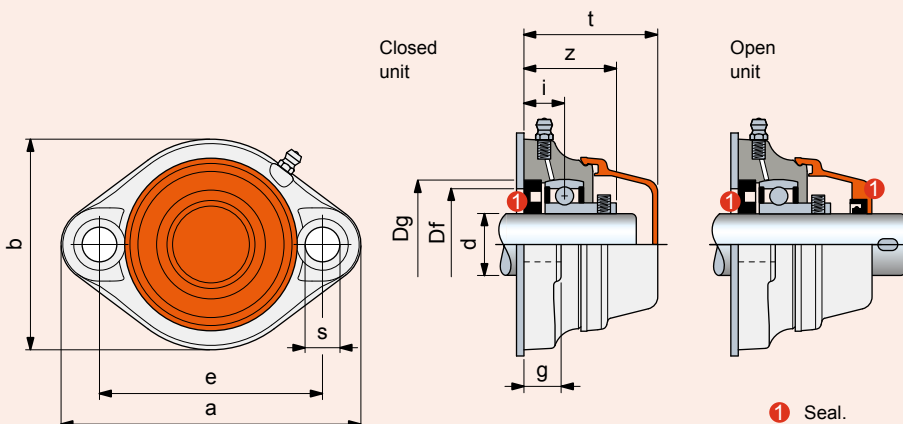

UCFLN/C - SUCFLN/C - HCFLN/C - SHCFLN/C

dia. d mm	Series	Housing material		Dimensions in mm											Bore in frame ¹⁾ Df		Bearing	Weight Kg	Spare parts Cover orange	
		Polyamide PA FV Solid Flange (black) Cover (orange)	Code	e	a	b	s	g	i	z	t	Dg	max.	min.	Code	Code				
Grub screws shaft locking • Closed unit																				
30*	SUCFLN 206 C	625933	90	122	85	11	15	15	37	54	62	60	50	Type A	0,37	626203				
Grub screws shaft locking • Open unit																				
30*	SUCFLN 206 C	625953	90	122	85	11	15	15	37	54	62	60	50	Type A	0,37	626223				

* = Version with special fixing holes.

¹⁾ = Dimensions Df max / Df min must be respected to ensure positive retention of the seals and to allow air bleeding during lubrication.

Packaging: 4 pieces.

Oval flange bearing units

UCFLN - SUCFLN - HCFLN - SHCFLN



Accessories

- **Material**
PA FV polyamide housing
 - Housing in reinforced polyamide PA FV resin (black)
 - Ball type nickel plated brass greasing nipple
 - Reinforcing bushings on mounting holes and washers in stainless steel AISI 304.
- **Continuous operating temperature**
 in air: - 20 to + 60°C.
- **Maximum allowed misalignment:** 2°.
- **Bearing**
 - Type B (grub screws shaft locking, chrome alloy steel, Superagriseal unit plus centrifuging ring)
 - Type C (grub screws shaft locking, stainless steel AISI 420, Superagriseal unit plus rubberised centrifuging ring)
 - Type A (grub screws shaft locking, chrome alloy steel, Superagriseal unit)
 - Prelubricated with lithium / calcium grease
 - Can be relubricated.

Grub screws or eccentric collar shaft locking

Version with bearing Type B

The double ring guarantees maximum protection against dust and non-corrosive substances.

Version with stainless steel bearing Type C

AISI 420 stainless steel bearing with 2 rubberised rings, provides excellent seal against humidity, steams, liquids, medium corrosive chemical agents. Maximum load ability is inferior.

Version with bearing Type A

The rubberised ring guarantees maximum protection against dusts.

Material

Polyamide PA FV guarantees maximum strength and high-temperature resistance.

Protection covers (accessories)

Closed cover

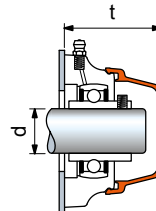

Open cover

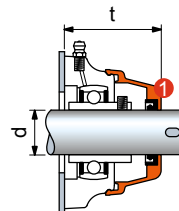

① Seals.

dia. d mm	Accessories	t mm	
	Cover orange	UCFL	HCFL
	Code		
Closed cover supplied			
30	63154	55	55
Open cover supplied with seals			
30*	626203/626223	54	54

* = Version with special fixing holes.

• Series UCFLN • Type B
Grub screws shaft locking

• Series UCFLN • Type C
Grub screws shaft locking

• Series UCFLN • Type A
Grub screws shaft locking

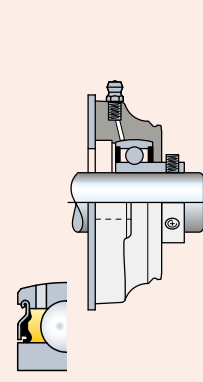
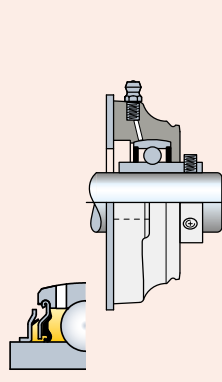
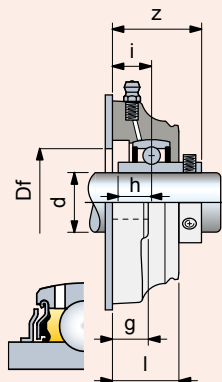
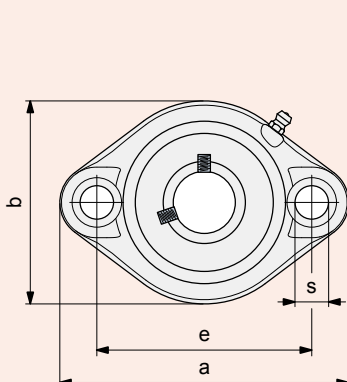

UCFLN - SUCFLN - HCFLN - SHCFLN

dia. d mm	Series	Housing material		Dimensions in mm									Bore in frame Df mm	Bearing	Weight Kg
		Polyamide PA FV Solid Flange (black)	Code	e	a	b	s	g	i	h	l	z			
Grub screws shaft locking • Version with bearing Type B															
30*	SUCFLN 206	633603		90	122	85	11	15	15	15,9	28	37,2	45	Type B	0,29
Grub screws shaft locking • Version with stainless steel bearing Type C															
30*	SUCFLN 206	633643		90	122	85	11	15	15	15,9	28	37,2	45	Type C	0,29
Grub screws shaft locking • Version with bearing Type A															
30*	SUCFLN 206	633693		90	122	85	11	15	15	-	28	37	34	Type A	0,29

Item code for order = B0000 + Code

* = Version with special fixing holes.

Packaging: 4 pieces.

Oval flange bearing units

UCFL/C - SUCFL/C - HCFL/C - SHCFL/C



Waterproof housing

Grub screws or eccentric collar shaft locking

PA FV polyamide housing

High mechanical and heat resistance. Proof to dust, humidity, washouts, steam, average aggressive chemical agents.

Solid flange bearings

They differ from standard flange versions for their closed surface structure, ideal for sanitation.

Material

PA FV polyamide housing

- Housing in reinforced polyamide PA FV resin (black)
- Protection cover in polypropylene PP (orange)
- Seal and O-Ring in NBR rubber (black)
- Ball type nickel plated brass greasing nipple
- Reinforcing bushings on mounting holes and washers in stainless steel AISI 304

Continuous operating temperature

in air: - 20 to + 60°C.

Maximum allowed misalignment: 2°.

Bearing



- Type A (grub screws shaft locking)
- Type D (eccentric collar shaft locking)
- Chrome alloy steel
- Supergriseal unit
- Prelubricated with lithium / calcium grease
- Can be relubricated.

• Series UCFL/C • Type A Grub screws shaft locking

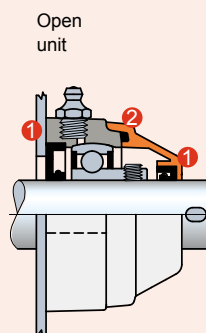
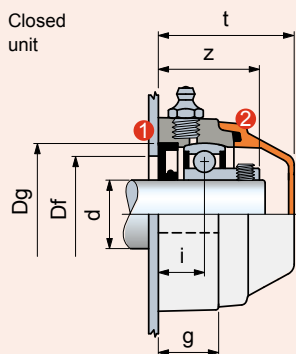

• Series HCFL/C • Type D Eccentric collar shaft locking

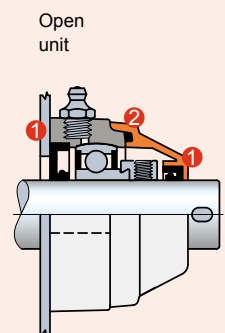
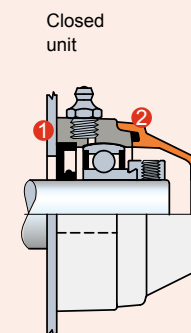

1 Seal.

2 O-Ring.

3 Only for series 206

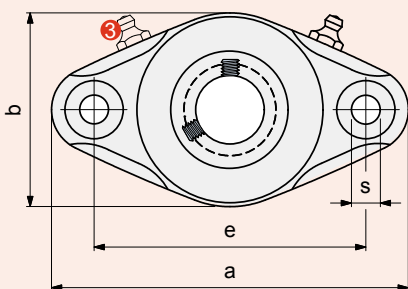

UCFL/C - SUCFL/C - HCFL/C - SHCFL/C

dia. d mm	Series	Housing material		Dimensions in mm										Bore in frame ²⁾ Df		Bearing	Weight Kg	Spare parts Cover orange	
		Polyamide PA FV Standard Flange (black) Cover (orange)	Code	e	a	b	s	g	i	z	t	Dg	max.	min.	Code			Code	
Grub screws shaft locking • Closed unit																			
20	UCFL 204 C	69016		90	116	62	11	20	15,2	33,2	46	47	45	40	Type A	0,25	681942		
25	UCFL 205 C	68523		99	130	71	11	22,5	16,8	36,3	49,5	52	50	45	Type A	0,33	681952		
30	UCFL 206 C	68399		117	148	85	11	26	20	42	56	62	60	50	Type A	0,42	63154		
35	UCFL 207 C	648131		130	162	93	11	26	19,5	43	59	72	70	55	Type A	0,65	682022		
40	UCFL 208 C	672411		144	176	102	11	30	22	47	65,5	80	78	65	Type A	0,90	63539		
40*	SUCFL 208 C	697712¹⁾		117	148	112	11	26	19	44	62	80	78	65	Type A	0,74	63539		
Grub screws shaft locking • Open unit																			
20	UCFL 204 C	69026		90	116	62	11	20	15,2	33,2	46	47	45	40	Type A	0,25	681962		
25	UCFL 205 C	68533		99	130	71	11	22,5	16,8	36,3	49,5	52	50	45	Type A	0,33	681972		
30	UCFL 206 C	68409		117	148	85	11	26	20	42	56	62	60	50	Type A	0,42	69965		
35	UCFL 207 C	648141		130	162	93	11	26	19,5	43	59	72	70	55	Type A	0,65	682032		
40	UCFL 208 C	672421		144	176	102	11	30	22	47	65,5	80	78	65	Type A	0,90	63549		
40*	SUCFL 208 C	697732¹⁾		117	148	112	11	26	19	44	62	80	78	65	Type A	0,74	63549		
Eccentric collar shaft locking • Closed unit																			
40*	SHCFL 208 C	697752¹⁾		117	148	112	11	26	19	51,7	68	80	78	65	Type D	0,93	600882		
Eccentric collar shaft locking • Open unit																			
40*	SHCFL 208 C	697772		117	148	112	11	26	19	51,7	68	80	78	65	Type D	0,93	600892		

* = Version with special fixing holes.

SUCFL206C/SHCFL206C: Assembly with cylindrical head screws.

¹⁾ = Solid flange.

²⁾ = Dimensions Df max / Df min must be respected to ensure positive retention of the seals and to allow air bleeding during lubrication.

Packaging: 4 pieces.

Oval flange bearing units

UCFL - SUCFL - HCFL - SHCFL



Accessories

- Material**
PA FV polyamide housing
 - Housing in reinforced polyamide PA FV resin (black)
 - Ball type nickel plated brass greasing nipple
 - Reinforcing bushings on mounting holes and washers in stainless steel AISI 304.
- Continuous operating temperature**
 in air: - 20 to + 60°C.
- Maximum allowed misalignment:** 2°.
- Bearing**
 - Type B (grub screws shaft locking, chrome alloy steel, Superagriseal unit plus centrifuging ring)
 - Type C (grub screws shaft locking, stainless steel AISI 420, Superagriseal unit plus rubberised centrifuging ring)
 - Type A (grub screws shaft locking, chrome alloy steel, Superagriseal unit)
 - Type D (eccentric collar shaft locking, chrome alloy steel, Superagriseal unit)
 - Prelubricated with lithium / calcium grease
 - Can be relubricated.

Grub screws or eccentric collar shaft locking

Version with bearing Type B

The double ring guarantees maximum protection against dust and non-corrosive substances.

Version with stainless steel bearing Type C

AISI 420 stainless steel bearing with 2 rubberised rings, provides excellent seal against humidity, steams, liquids, medium corrosive chemical agents. Maximum load ability is inferior.

Version with bearing Type A

The rubberised ring guarantees maximum protection against dusts.

Material

Polyamide PA FV guarantees maximum strength and high-temperature resistance.

Protection covers (accessories)

Closed cover

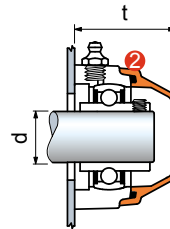

Open cover

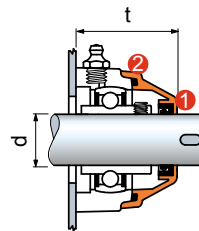

dia. d mm	Accessories	t mm	
	Cover orange Code	UCFL	HCFL
Closed cover supplied with seals			
17*	681942	46	49
20	681942	46	49
25	681952	49,5	49,5
25*	681952	49,5	49,5
30	63154	55	55
30*	63154	55	55
35	682022	59	59
40 ²⁾	600882	-	71
Open cover supplied with seals			
17*	696162	46	49
25	681972	49,5	49,5
25*	681972	49,5	49,5
30	69965	55	55
30*	69965	55	55
35	682032	59	59
35*	615692	62	62
40 ¹⁾	63549	65,5	-

- 1 Seals.
- 2 Seals O-Ring.
- 3 Only for series 206

* = Version with special fixing holes.

1) = Protection cover for bearing unit with grub screws shaft locking.

2) = Protection cover for bearing unit with eccentric collar shaft locking.

• Series UCFL • Type B
Grub screws shaft locking

• Series UCFL • Type C
Grub screws shaft locking

• Series UCFL • Type A
Grub screws shaft locking

• Series HCFL • Type D
Eccentric collar shaft locking

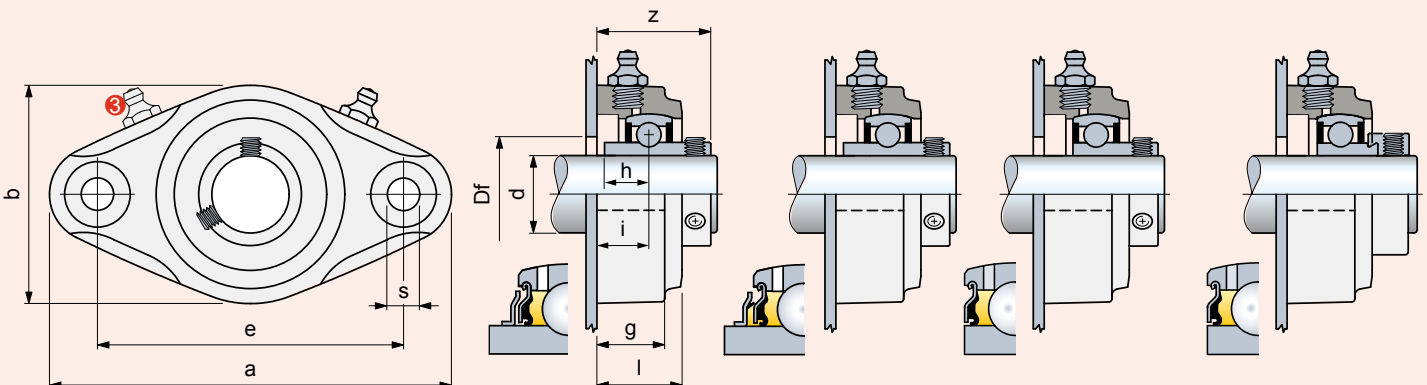

UCFL - SUCFL - HCFL - SHCFL

dia. d mm	Series	Housing material		Dimensions in mm									Bore in frame Df mm	Bearing	Weight Kg
		Polyamide PA FV Standard Flange (black)	Code	e	a	b	s	g	i	h	l	z			
Grub screws shaft locking • Version with bearing Type B															
20	UCFL 204	69056		90	116	62	11	20	15,2	12,7	25	33,5	24	Type B	0,25
25	UCFL 205	68563		99	130	71	11	22,5	16,8	14,3	27,5	36,5	29	Type B	0,31
30	UCFL 206	68439		117	148	85	11	26	19	15,9	32,5	42,2	34	Type B	0,44
Grub screws shaft locking • Version with stainless steel bearing Type C															
20	UCFL 204	646542		90	116	62	11	20	15,2	12,7	25	33,5	24	Type C	0,25
25	UCFL 205	646552		99	130	71	11	22,5	16,8	14,3	27,5	36,6	29	Type C	0,31
30	UCFL 206	646562		117	148	85	11	26	19	15,9	32,5	42,2	34	Type C	0,44
Grub screws shaft locking • Version with bearing Type A															
20	UCFL 204	655482		90	116	62	11	20	15,2	-	25	33,2	24	Type A	0,23
25	UCFL 205	655472		99	130	71	11	22,5	16,8	-	27,5	36,3	29	Type A	0,31
30	UCFL 206	666412		117	148	85	11	26	20	-	32,5	42	34	Type A	0,39
40*	SUCFL 208	602193¹⁾		117	148	112	11	26	19	-	33	44	44	Type A	0,91
Eccentric collar shaft locking • Version with bearing Type D															
40*	SHCFL 208	602213¹⁾		117	148	112	11	26	19	-	33	51,7	44	Type D	0,91

* = Version with special fixing holes.

SUCFL/SHCFL: Assembly with cylindrical head screws.

¹⁾ = Solid flange.

Packaging: 4 pieces.

Pillow block type bearing units

UCP/C - HCP/C



Waterproof housing

Grub screws or eccentric collar shaft locking

PA FV polyamide housing

High mechanical and heat resistance. Proof to dust, humidity, washouts, steam, average aggressive chemical agents.

PP FV polypropylene housing

Proof to highly aggressive chemical agents. Inferior loading ability.

Material

PA FV polyamide housing

- Housing in reinforced polyamide PA FV resin (black)
- Protection cover in polypropylene PP (orange)
- Seal and O-Ring in NBR rubber (black)
- Ball type nickel plated brass greasing nipple
- Reinforcing bushings on mounting holes and washers in stainless steel AISI 304
- Stainless steel AISI 303 safety ring.

Continuous operating temperature

in air: - 20 to + 60°C.

Maximum allowed misalignment: 2°.

Bearing



- Type A (grub screws shaft locking)
- Type D (eccentric collar shaft locking)
- Chrome alloy steel
- Superagriseal unit
- Prelubricated with lithium / calcium grease
- Can be relubricated.

• Series UCP/C • Type A Grub screws shaft locking

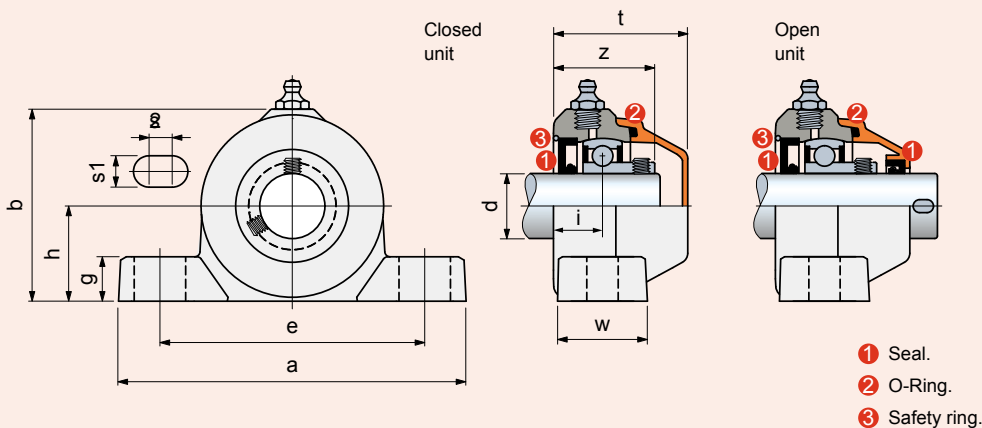

dia. d mm	Series	Housing material		Dimensions in mm												Bearing	Weight Kg	Spare parts	
		Polyamide PA FV Flange (black) Cover (orange)	Code	e	a	h	b	s1	s2	g	w	i	z	t	Code			Code	
Grub screws shaft locking • Closed unit																			
20	UCP 204 C	682941	96	128	33,3	67	12	10	17	30	18,9	36,9	49,7	Type A	0,27	681942			
25	UCP 205 C	646511	106	140	36,5	75	12	10	17	34,5	18,8	38,3	51,5	Type A	0,33	681952			
Grub screws shaft locking • Open unit																			
20	UCP 204 C	682931	96	128	33,3	67	12	10	17	30	18,9	36,9	49,7	Type A	0,27	681962			
25	UCP 205 C	646521	106	140	36,5	75	12	10	17	34,5	18,8	38,3	51,5	Type A	0,33	681972			

Packaging: 4 pieces.

Pillow block type bearing units

UCP - HCP



Accessories

Material

PA FV polyamide housing

- Housing in reinforced polyamide PA FV resin (black)
- Ball type nickel plated brass greasing nipple
- Reinforcing bushings on mounting holes and washers in stainless steel AISI 304.

Continuous operating temperature

in air: - 20 to + 60°C.

Maximum allowed misalignment: 2°.

Bearing

- Type B (grub screws shaft locking, chrome alloy steel, Superagriseal unit plus centrifuging ring)
- Type C (grub screws shaft locking, stainless steel AISI 420, Superagriseal unit plus rubberised centrifuging ring)
- Type A (grub screws shaft locking, chrome alloy steel, Superagriseal unit)
- Type D (eccentric collar shaft locking, chrome alloy steel, Superagriseal unit)
- Prelubricated with lithium / calcium grease
- Can be relubricated.

Grub screws or eccentric collar shaft locking

Version with bearing Type B

The double ring guarantees maximum protection against dust and non-corrosive substances.

Version with stainless steel bearing Type C

AISI 420 stainless steel bearing with 2 rubberised rings, provides excellent seal against humidity, steams, liquids, medium corrosive chemical agents. Maximum load ability is inferior.

Version with bearing Type A

The rubberised ring guarantees maximum protection against dusts.

Material

Polyamide PA FV guarantees maximum strength and high-temperature resistance.

Protection covers (accessories)

Closed cover

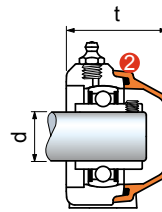

Open cover

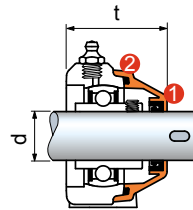

1 Seals.

2 Seals O-Ring.

dia. d mm	Accessories	t mm	
	Cover orange Code	UCFL	HCFL
Closed cover supplied with seals			
20	681942	49,7	52
25	681952	51,5	51,5
30	63154	55	55
35	682022	61	61
40 ²⁾	600882	-	72
Open cover supplied with seals			
25	681972	51,5	51,5
30	69965	55	55
35	682032	61	61
40 ¹⁾	63549	66,5	-

¹⁾ = Protection cover for bearing unit with grub screws shaft locking.

²⁾ = Protection cover for bearing unit with eccentric collar shaft locking.

• Series UCP • Type B
Grub screws shaft
locking

• Series UCP • Type C
Grub screws shaft
locking

• Series UCP • Type A
Grub screws shaft
locking

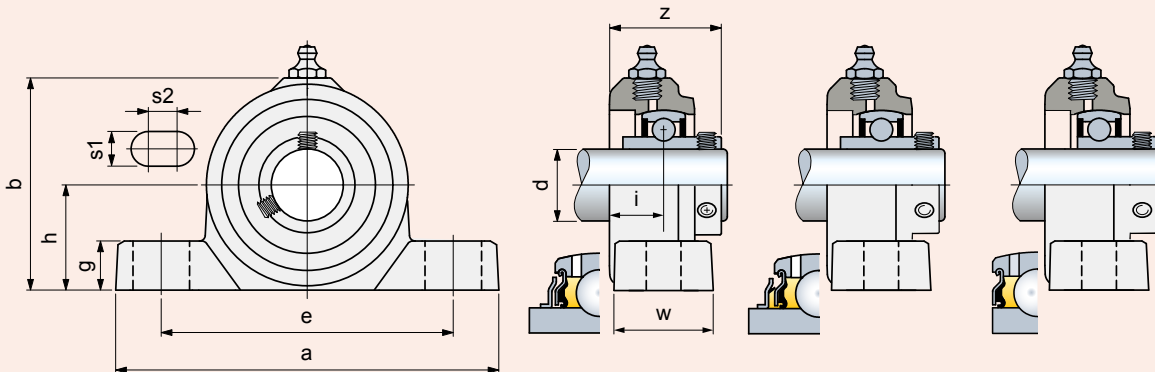

dia. d mm	Series	Housing material	Dimensions in mm											Bearing	Weight Kg
		Polyamide PA FV Flange (black) Code	e	a	h	b	s1	s2	g	w	i	z			
Grub screws shaft locking • Version with bearing Type B															
25	UCP 205	648781	106	140	36,5	75	12	10	17	34,5	18,8	38,5	Type B	0,33	
Grub screws shaft locking • Version with stainless steel bearing Type C															
25	UCP 205	646502	106	140	36,5	75	12	10	17	34,5	18,8	38,6	Type C	0,33	
Grub screws shaft locking • Version with bearing Type A															
25	UCP 205	678562	106	140	36,5	75	12	10	17	34,5	18,8	38,3	Type A	0,30	

Packaging: 4 pieces.

Compact pillow block

UCPA/C - HCPA/C



Waterproof housing

Grub screws or eccentric collar shaft locking

PA FV polyamide housing

High mechanical and heat resistance. Proof to dust, humidity, washouts, steam, average aggressive chemical agents.

Material

PA FV polyamide housing

- Housing in reinforced polyamide PA FV resin (black)
- Protection cover in polypropylene PP (orange)
- Seal and O-Ring in NBR rubber (black)
- Ball type nickel plated brass greasing nipple
- Nickel plated brass threaded bushings.

Continuous operating temperature

in air: - 20 to + 60°C.

Maximum allowed misalignment: 2°.

Bearing



- Type A (grub screws shaft locking)
- Chrome alloy steel
- Superagriseal unit
- Prelubricated with lithium / calcium grease
- Can be relubricated.

• Series UCPA/C • Type A Grub screws shaft locking

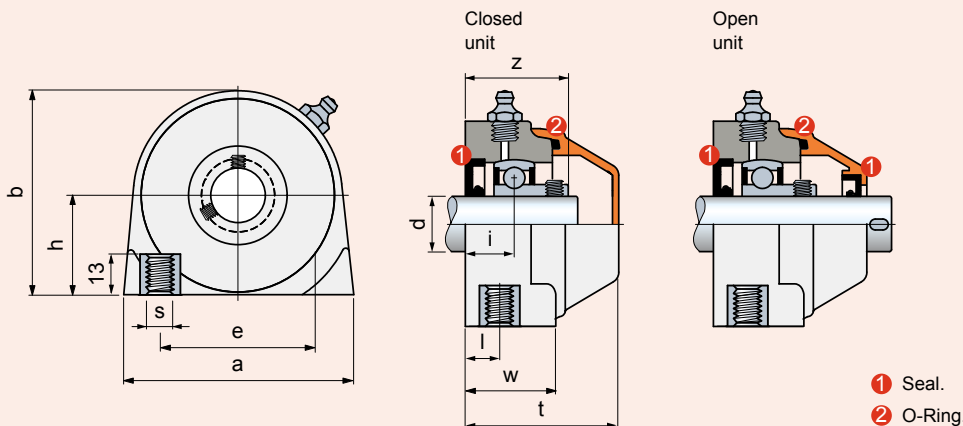

dia. d mm	Series	Housing material	Dimensions in mm											Bearing	Weight Kg	Spare parts Cover orange
		Code	e	a	h	b	s	w	i	l	z	t	Code			
Grub screws shaft locking • Closed unit																
25	UCPA 205 C	696202	50,8	75	36,5	72	M10	30	16,8	12	36,3	52	Type A	0,29	681952	
Grub screws shaft locking • Open unit																
25	UCPA 205 C	696232	50,8	75	36,5	72	M10	30	16,8	12	36,3	52	Type A	0,29	681972	

Packaging: 4 pieces.

Side flange bearing units

UCFB/C - HCFB/C



The picture shows
d. 20 - 25 version.

For other versions please
see the technical drawing.

Waterproof housing

Grub screws or eccentric collar shaft locking

PA FV polyamide housing

High mechanical and heat resistance. Proof to dust, humidity, washouts, steam, average aggressive chemical agents.

Solid flange bearings

They differ from standard flange versions for their closed surface structure, ideal for sanitation.

Material

PA FV polyamide housing

- Housing in reinforced polyamide PA FV resin (black)
- Protection cover in polypropylene PP (orange)
- Seal and O-Ring in NBR rubber (black)
- Ball type nickel plated brass greasing nipple
- Reinforcing bushings on mounting holes and washers in stainless steel AISI 304

Continuous operating temperature

in air: - 20 to + 60°C.

Maximum allowed misalignment: 2°.

Bearing



- Type A (grub screws shaft locking)
- Chrome alloy steel
- Superagriseal unit
- Prelubricated with lithium / calcium grease
- Can be relubricated.

• Series UCFB/C • Type A Grub screws shaft locking

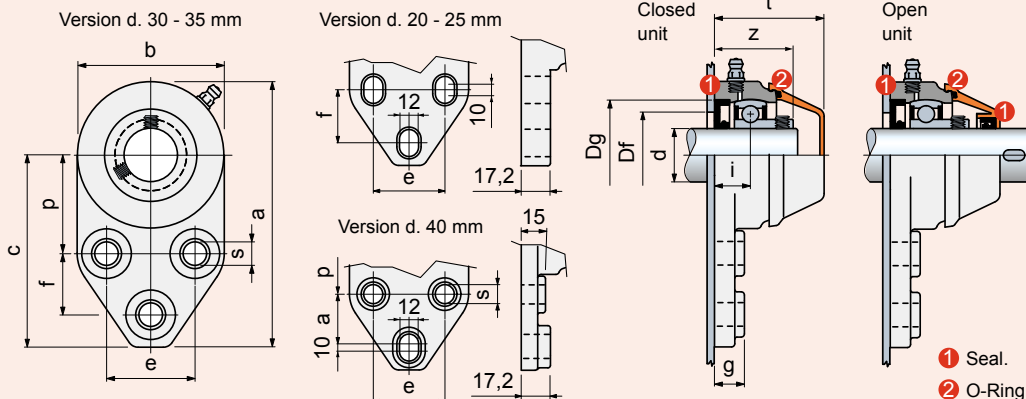

UCFB/C - HCFB/C

dia. d mm	Series	Housing material		Dimensions in mm														Bore in frame ¹⁾ Df		Bearing	Weight Kg	Spare parts Cover orange	
		Polyamide PA FV Standard Flange (black) Cover (orange)	Code	a	b	c	p	e	f	s	g	i	z	t	Dg	max.	min.	Code	Code				
Grub screws shaft locking • Closed unit																							
25	UCFB 205 C	656542N	124,2	68,8	89,8	46	41,3	28,6	11	17,2	17,8	37,3	52	52	50	45	Type A	0,32	681952				
30	UCFB 206 C	656562	138,6	81,3	97,9	52,4	47,6	31,7	11	14	20	42	55	62	60	50	Type A	0,47	63154				
Grub screws shaft locking • Open unit																							
25	UCFB 205 C	656552N	124,2	68,8	89,8	46	41,3	28,6	11	17,2	17,8	37,3	52	52	50	45	Type A	0,32	681972				
30	UCFB 206 C	656572	138,6	81,3	97,9	52,4	47,6	31,7	11	14	20	42	55	62	60	50	Type A	0,47	69965				

¹⁾ = Dimensions Df max / Df min must be respected to ensure positive retention of the seals and to allow air bleeding during lubrication.
Packaging: 4 pieces.

Side flange bearing units

UCFB - HCFB



The picture shows
d. 20 - 25 version.

For other versions please
see the technical drawing.



Accessories

Material

PA FV polyamide housing

- Housing in reinforced polyamide PA FV resin (black)
- Ball type nickel plated brass greasing nipple
- Reinforcing bushings on mounting holes in stainless steel AISI 304.

Continuous operating temperature

in air: - 20 to + 60°C.

Maximum allowed misalignment: 2°.

Bearing

- Type B (grub screws shaft locking, chrome alloy steel, Superagriseal unit plus centrifuging ring)
- Type C (grub screws shaft locking, stainless steel AISI 420, Superagriseal unit plus rubberised centrifuging ring)
- Type A (grub screws shaft locking, chrome alloy steel, Superagriseal unit)
- Prelubricated with lithium / calcium grease
- Can be relubricated.

Grub screws or eccentric collar shaft locking

Version with bearing Type B

The double ring guarantees maximum protection against dust and non-corrosive substances.

Version with stainless steel bearing Type C

AISI 420 stainless steel bearing with 2 rubberised rings, provides excellent seal against humidity, steams, liquids, medium corrosive chemical agents. Maximum load ability is inferior.

Version with bearing Type A

The rubberised ring guarantees maximum protection against dusts.

Material

Polyamide PA FV guarantees maximum strength and high-temperature resistance.

Protection covers (accessories)

Closed cover

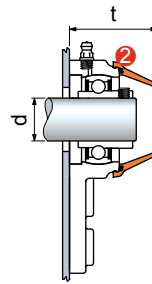

Open cover

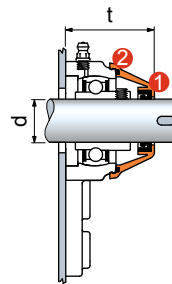

- ① Seals.
- ② Seals O-Ring.

dia. d mm	Accessories	t mm	
	Cover orange Code	UCFL	HCFL
Closed cover supplied with seals			
20	681942	49	49
25	681952	52	57
30	63154	55	60
35	682022	59	64,5
40	600882	72	72
Open cover supplied with seals			
25	681972	52	57
30	69965	55	60
35	682032	59	64,5

• Series UCFB • Type B Grub screws shaft locking

• Series UCFB • Type C Grub screws shaft locking

• Series UCFB • Type A Grub screws shaft locking

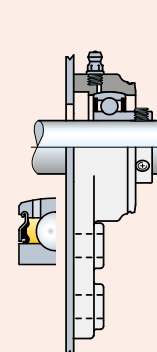
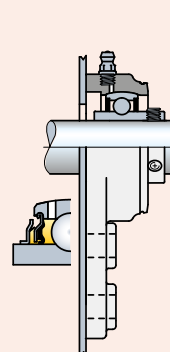
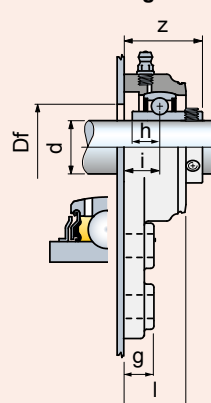
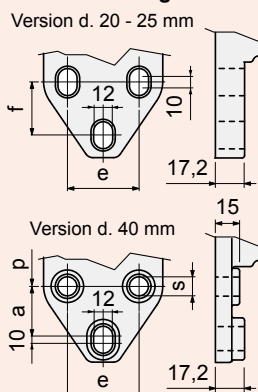
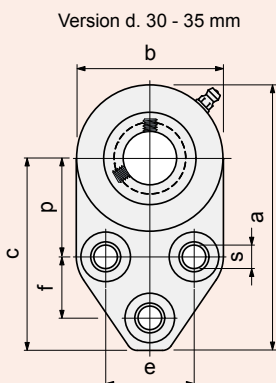

dia. d mm	Series	Housing material		Dimensions in mm												Bore in frame Df mm	Bearing	Weight Kg
		Polyamide PA FV Solid Flange (black)	Code	a	b	c	p	e	f	s	g	i	h	l	z			
Grub screws shaft locking • Version with bearing Type B																		
25	UCFB 205	663912N		124,2	68,8	89,8	46	41,3	28,6	11	17,2	17,8	14,3	29	37,5	29	Type B	0,33
30	UCFB 206	663922		138,6	81,3	97,9	52,4	47,6	31,7	11	14	20	15,9	31,5	42,2	34	Type B	0,50
Grub screws shaft locking • Version with stainless steel bearing Type C																		
25	UCFB 205	663942N		124,2	68,8	89,8	46	41,3	28,6	11	17,2	17,8	14,3	29	37,6	29	Type C	0,33
30	UCFB 206	663952		138,6	81,3	97,9	52,4	47,6	31,7	11	14	20	15,9	31,5	42,2	34	Type C	0,50
Grub screws shaft locking • Version with bearing Type A																		
25	UCFB 205	663672N		124,2	68,8	89,8	46	41,3	28,6	11	17,2	17,8	-	29	37,3	29	Type A	0,30
30	UCFB 206	663682		138,6	81,3	97,9	52,4	47,6	31,7	11	14	20	-	31,5	42	34	Type A	0,45

Packaging: 4 pieces.

Side flange bearing units

SQL/C



Grub screws shaft locking

PP FV polypropylene housing

Proof to highly aggressive chemical agents.

Inferior loading ability.

Solid flange bearings

Closed surface structure, ideal for sanitation.

Material

PP FV polypropylene housing

- Housing in reinforced polypropylene PP FV resin (black)
- Protection cover in polypropylene PP (orange)
- Seal and O-Ring in NBR rubber (black)
- Ball type stainless steel AISI 316 greasing nipple
- Washers in stainless steel AISI 304.

Continuous operating temperature

in air: - 20 to + 60°C.

Maximum allowed misalignment: 2°.

Bearing



- Grub screws shaft locking
- Chrome alloy steel
- Superagriseal unit
- Prelubricated with lithium / calcium grease
- Can be relubricated.

**• Series SQL/C • Type A
Grub screws shaft locking**

Closed unit Right

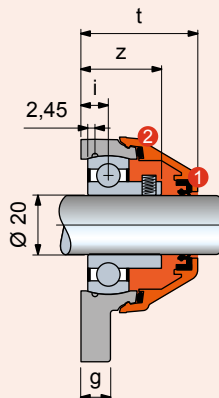
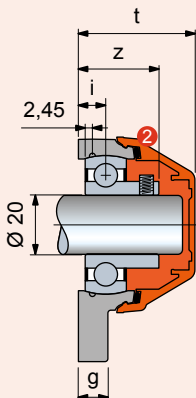
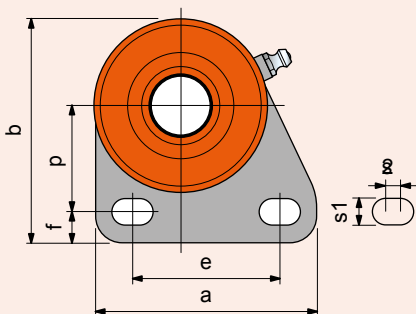

Open unit Left

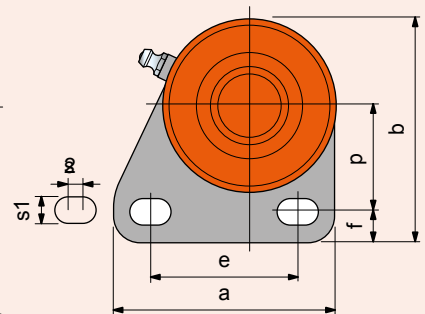

- 1 Seal.
- 2 O-Ring.

dia. d mm	Series	Housing material	Dimensions in mm												Bearing	Weight Kg	Spare parts Cover orange
		Polypropylene PP FV Solid Flange (black) Cover (orange)	Code	e	a	b	s1	s2	g	i	z	t	f	p			Code
Closed unit Left																	
20	SQL 204 C	656263	50	75	76	9	5	10	9,3	27,3	39,5	10,5	36	Type A	0,20	681942	
Open unit Left																	
20	SQL 204 C	656273	50	75	76	9	5	10	9,3	27,3	39,5	10,5	36	Type A	0,20	681962	
Closed unit Right																	
20	SQL 204 C	656283	50	75	76	9	5	10	9,3	27,3	39,5	10,5	36	Type A	0,20	681942	
Open unit Right																	
20	SQL 204 C	656293	50	75	76	9	5	10	9,3	27,3	39,5	10,5	36	Type A	0,20	681962	

Packaging: 4 pieces.

Side flange bearing units

SQL



Accessories

Grub screws shaft locking

PP FV polypropylene housing

Proof to highly aggressive chemical agents.

Inferior loading ability.

Solid flange bearings

Closed surface structure, ideal for sanification.

Material

PP FV polypropylene housing

- Housing in reinforced polypropylene PP FV resin (black)
- Ball type stainless steel AISI 316 greasing nipple
- Washers in stainless steel AISI 304.

Continuous operating temperature

in air: - 20 to + 60°C.

Maximum allowed misalignment: 2°.

Bearing



- Grub screws shaft locking
- Chrome alloy steel
- Superagriseal unit
- Prelubricated with lithium / calcium grease
- Can be relubricated.

**• Series SQL • Type A
Grub screws shaft locking**

Right unit

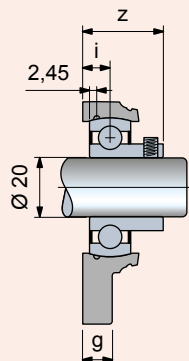
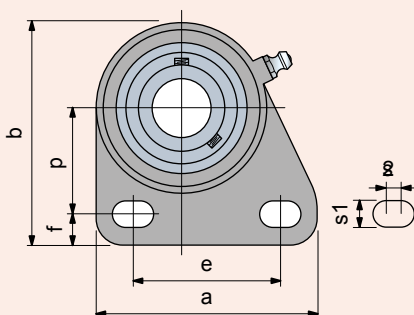

Left unit

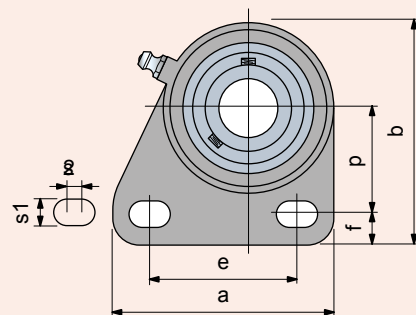

dia. d mm	Series	Housing material	Dimensions in mm											Weight Kg
		Polypropylene PP FV Solid Flange (black) Code	e	a	b	s1	s2	g	i	z	f	p	Bearing	
Left unit														
20	SQL 204	656303	50	75	76	9	5	10	9,3	27,3	10,5	36	Type A	0,18
Right unit														
20	SQL 204	656313	50	75	76	9	5	10	9,3	27,3	10,5	36	Type A	0,18

Packaging: 6 pieces.

Take-up bearing units

UCT/C - HCT/C



Waterproof housing

Grub screws or eccentric collar shaft locking

PA FV polyamide housing

High mechanical and heat resistance. Proof to dust, humidity, washouts, steam, average aggressive chemical agents.

Material

PA FV polyamide housing

- Housing in reinforced polyamide PA FV resin (black)
- Protection cover in polypropylene PP (orange)
- Seal and O-Ring in NBR rubber (black)
- Ball type nickel plated brass greasing nipple
- Threaded insert in nickel plated brass.

Continuous operating temperature

in air: - 20 to + 60°C.

Maximum allowed misalignment: 2°.

Bearing



- Type A (grub screws shaft locking)
- Chrome alloy steel
- Superagriseal unit
- Prelubricated with lithium / calcium grease
- Can be relubricated.

Assembly

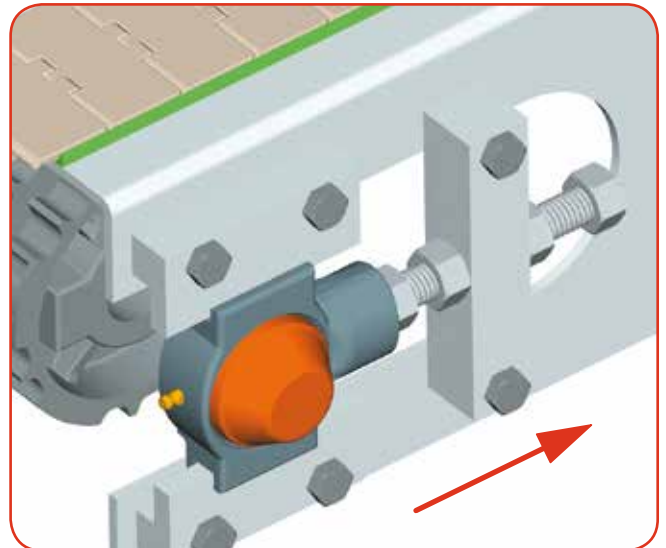

Working load allowed only in this direction.

• Series UCT/C • Type A Grub screws shaft locking

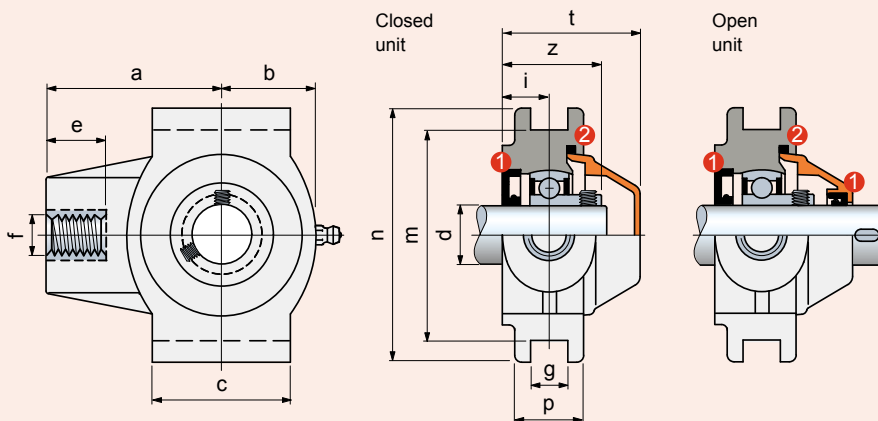

dia. d mm	Series	Housing material		Dimensions in mm												Bearing	Weight Kg	Spare parts	
		Polyamide PA FV Flange (black) Cover (orange)	Code	a	b	c	e	f	g	i	m	n	p	z	t			Code	Code
Grub screws shaft locking • Closed unit																			
25	UCT 205 C	666962	68,5	39,5	50	28	M20	13,5	17	76,2	92	25	36,5	52	Type A	0,39	681872		
Grub screws shaft locking • Open unit																			
25	UCT 205 C	666992	68,5	39,5	50	28	M20	13,5	17	76,2	92	25	36,5	52	Type A	0,39	681892		

Packaging: 4 pieces.

Round flange bearing units

UCFC/C



Waterproof housing

Grub screws shaft locking

PA FV polyamide housing

High mechanical and heat resistance. Proof to dust, humidity, washouts, steam, average aggressive chemical agents.

Material

PA FV polyamide housing

- Housing in reinforced polyamide PA FV resin (black)
- Protection cover in polypropylene PP (orange)
- Seal and O-Ring in NBR rubber (black)
- Ball type nickel plated brass greasing nipple
- Reinforcing bushings on mounting holes and washers in stainless steel AISI 304

Continuous operating temperature

in air: - 20 to + 60°C.

Maximum allowed misalignment: 2°.

Bearing



- Type A (grub screws shaft locking)
- Chrome alloy steel
- Superagriseal unit
- Prelubricated with lithium / calcium grease
- Can be relubricated.

• Closed unit

• Open unit

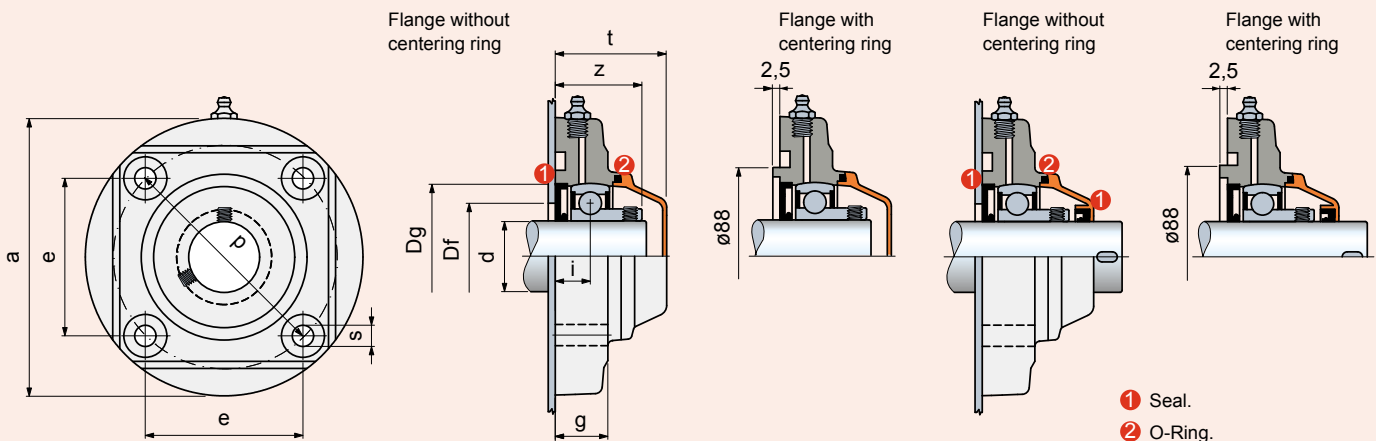

Housing material

dia. d mm	Flange	Series	Polyamide PA FV Standard Flange (black) Cover (orange)		Dimensions in mm										Bore in frame ¹⁾ Df		Bearing	Weight Kg	Spare parts Cover orange	
			Code		e	a	p	s	g	i	z	t	Dg	max.	min.	Code			Code	
Closed unit																				
35	Without centering ring	UCFC 207 C	683921		77,8	137	110	11	26	17,3	40,8	55	72	70	55	Type A	0,75	603772		
	With centering ring	UCFC 207 C	624772		77,8	137	110	11	26	17,3	40,8	55	72	-	-	Type A	0,75	603772		
Open unit																				
35	Without centering ring	UCFC 207 C	683931		77,8	137	110	11	26	17,3	40,8	55	72	70	55	Type A	0,75	603792		
	With centering ring	UCFC 207 C	624782		77,8	137	110	11	26	17,3	40,8	55	72	-	-	Type A	0,75	603792		

¹⁾ = Dimensions Df max / Df min must be respected to ensure positive retention of the seals and to allow air bleeding during lubrication.

Packaging: 4 pieces.

Round flange bearing units

UCFC



Material

PA FV polyamide housing

- Housing in reinforced polyamide PA FV resin (black)
- Ball type nickel plated brass greasing nipple
- Reinforcing bushings on mounting holes and washers in stainless steel AISI 304.

Continuous operating temperature

in air: - 20 to + 60°C.

Maximum allowed misalignment: 2°.

Bearing

- Type B (grub screws shaft locking, chrome alloy steel, Superagriseal unit plus centrifuging ring)
- Type C (grub screws shaft locking, stainless steel AISI 420, Superagriseal unit plus rubberised centrifuging ring)
- Type A (grub screws shaft locking, chrome alloy steel, Superagriseal unit)
- Prelubricated with lithium / calcium grease
- Can be relubricated.

Grub screws shaft locking

Version with bearing Type B

The double ring guarantees maximum protection against dust and non-corrosive substances.

Version with stainless steel bearing Type C

AISI 420 stainless steel bearing with 2 rubberised rings, provides excellent seal against humidity, steams, liquids, medium corrosive chemical agents. Maximum load ability is inferior.

Version with bearing Type A

The rubberised ring guarantees maximum protection against dusts.

Material

Polyamide PA FV guarantees maximum strength and high-temperature resistance.

dia. d mm	Accessories Cover orange Code	t mm
Closed cover supplied without seals		
35	63232	50
Open cover supplied with seals		
35	604042	50

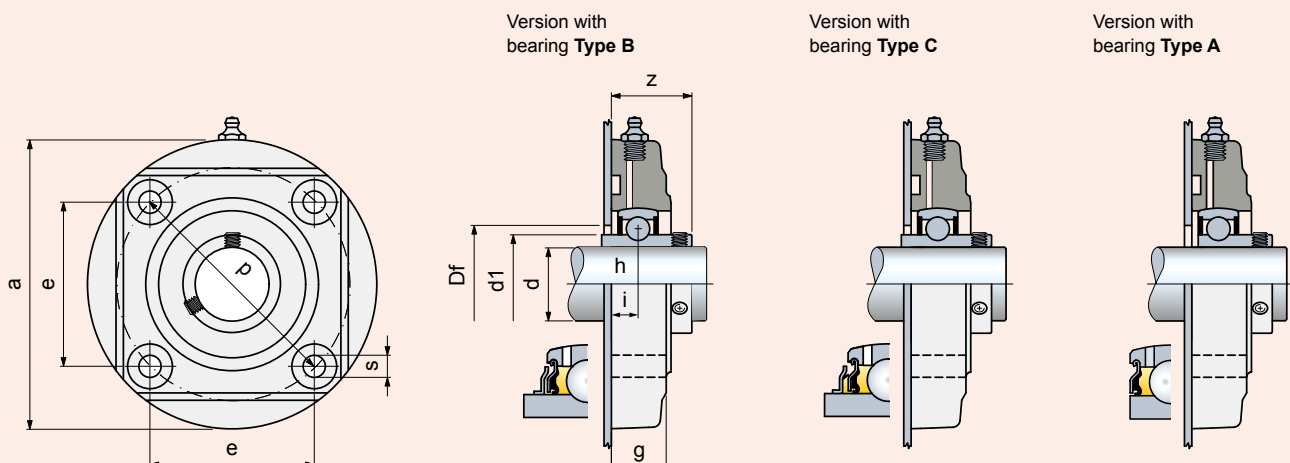

dia. d mm	Series	Housing material		Dimensions in mm										Bore in frame Df mm	Bearing	Weight Kg
		Polyamide PA FV Standard Flange (black)	Code	e	a	p	s	g	i	h	z	d1				
Version with bearing Type B																
35	UCFC 207	60752		77,8	137	110	11	26	12,3	17,5	37,7	46,1	50	Type B	0,75	
Version with stainless steel bearing Type C																
35	UCFC 207	646652		77,8	137	110	11	26	12,3	17,5	37,7	46,1	50	Type C	0,75	
Version with bearing Type A																
35	UCFC 207	681822		77,8	137	110	11	26	17,3	17,5	40,8	46,1	50	Type A	0,75	

Item code for order = B0000 + Code

Packaging: 6 pieces.

Round flange bearing units

SBF



Stainless steel AISI 304 flange

Stainless steel bearing Type C

AISI 420 stainless steel bearing with 2 rubberised rings, provides excellent seal against humidity, steams, liquids, medium corrosive chemical agents.

Load capacity

The pressed steel flanged support is suitable for light duties.

Material

Pressed stainless steel AISI 304 flanges.

Continuous operating temperature

in air: - 20 to + 60°C.

Maximum allowed misalignment: 5°.

Bearing



- Type C (grub screws shaft locking)
- stainless steel AISI 420
- Superagriseal unit plus rubberised centrifuging ring
- Prelubricated with lithium / calcium grease
- Can be relubricated.

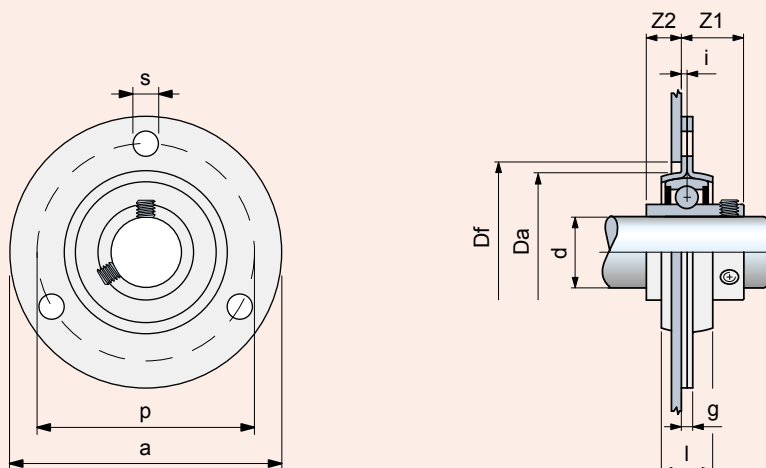

dia. d mm	Series	Housing material		Dimensions in mm									Bore in frame Df mm	Bearing	Weight Kg
		Stainless Steel AISI 304	Code	p	a	s	g	i	l	Z1	Z2	Da			
25	SBF 205	Stainless Steel AISI 304	604562	76	95	8,7	4	2	18	21,8	12,3	56	60	Type C	0,35

Packaging: 4 pieces.

Technical information

Bearing unit max. static load

B68

Bearings

- Bearings with grub screw locking system B72
- Bearings with self locking eccentric collar B72
- Seals B73
- Maximum velocities B73
- Axial load capacities B73
- Self aligning ball bearings, holding by shoulders on shaft B73

Calculation data

- Definition of bearing dimensions B74
- Calculation method for self-aligning bearings B74
- Life B74
- Life expectation calculation B74
- Equivalent dynamic load calculation B75
- Static load capacity control B76
- Equivalent static load calculation B76

Lubrication

- Prelubrication B77
- Lubrication grease B77
- Relubrication B77
- Relubrication intervals B77

Grease life in bearings lubricated for life

- Formula to calculate grease life B78
- Diagram 1 grease nominal life B78
- Diagram 2 correction factor B79
- Example of calculation B79

Shaft tolerances

- Shaft tolerances for bearings with grub screws or eccentric collar locking system B80
- Shaft tolerances for bearings with shoulders type holding system B80



Mounting

- Mounting recommendations B81
- Bearing locking by grub screws B81
- Bearing locking by eccentric collar B81
- Installation/removal of covers B81

Bearing unit max. static load

**UCF/C - SUCF/C - HCF/C - SHCF/C - UCF/CL - SUCF/CL
HCF/CL - SHCF/CL - UCF - SUCF - HCF - SHCF**





Shaft dia. d mm				
	PA FV N	PP FV N	PA FV N	PP FV N
25	19550	13800	20700	11500
30	19550	13800	20700	11500
35	20700	13800	25300	13800
35*	19550	13800	20700	11500
40	20700	14375	25300	13800
40*	19550	13800	20700	11500
45*	32000	24000	35000	26000
50*	32000	24000	35000	26000

* = Version with special fixing holes

UCFS/C - SUCFS/C - HCFS/C - SHCFS/C





Shaft dia. d mm				
	PA FV N	PP FV N	PA FV N	PP FV N
30	20700	25300		
35*	20700	25300		
40*	20700	25300		

* = Version with special fixing holes

F - SF



Shaft dia. d mm						
	PA FV N	PP FV N	PA FV N	PP FV N	PA FV N	PP FV N
30	21850	16100	17250	13800	8050	5750
35	21850	16100	17250	13800	18400	10350
40	21850	17250	17250	13800	19550	13800
40*	21850	16100	17250	13800	18400	10350
45	23000	17250	18400	14350	19550	13800
45*	21850	16100	17250	13800	18400	10350

* = Version with special fixing holes

Bearing unit max. static load

UCFLN/C - SUCFLN/C - HCFLN/C - SHCFLN/C UCFLN/CL - SUCFLN/CL - HCFLN/CL - SHCFLN/CL



Shaft dia. d mm				
	PA FV N	PP FV N	PA FV N	PP FV N
17	9775	6325	9775	6900
20*	9775	6325	9775	6900
25*	10925	7475	11500	7475
30	14950	9200	14375	11500
30*	14950	9200	14375	11500

* = Version with special fixing holes

UCFLN - SUCFLN - HCFLN - SHCFLN



Shaft dia. d mm				
	PA FV N	PP FV N	PA FV N	PP FV N
17	9775	6325	9775	6900
20*	9775	6325	9775	6900
25*	10925	7475	11500	7475
30	14950	9200	14375	11500
30*	14950	9200	14375	11500

* = Version with special fixing holes

UCFL/C - SUCFL/C - HCFL/C - SHCFL/C - UCFL/CL - SUCFL/CL HCFL/CL - SHCFL/CL - UCFL - SUCFL - HCFL - SHCFL



Shaft dia. d mm				
	PA FV N	PP FV N	PA FV N	PP FV N
17	9775	6325	9775	6900
20	9775	6325	9775	6900
25	10925	7475	11500	7475
25*	10925	7475	11500	7475
30	14950	9200	14375	11500
30*	14950	9200	14375	11500
35	14950	9200	13225	10925
35*	14950	9200	14375	11500
40	14950	9775	14950	10925
40*	14950	9200	14375	11500

* = Version with special fixing holes

UCFLS/C - SUCFLS/C - HCFLS/C - SHCFLS/C



Shaft dia. d mm		
	PA FV N	PP FV N
30	14950	14375
35*	14950	13225
40*	14950	14950

* = Version with special fixing holes

FL



Shaft dia. d mm						
	PA FV N	PP FV N	PA FV N	PP FV N	PA FV N	PP FV N
25	9200	6900	11500	8625	12650	5750
30	11500	6900	12650	9200	13800	5750
35	11500	9200	12650	9200	9200	4600
40	12650	9200	12650	9200	13800	6900
45	12650	9200	13800	9775	17250	12650

Bearing unit max. static load



UCFX/T - SUCFX/T - HCFX/T- SHCFX/T



Shaft dia. d mm		
	PA FV N	PA FV N
30	45000	45000
35	45000	45000
40	45000	45000





UCP/C - HCP/C - UCP - HCP



Shaft dia. d mm						
	PA FV N	PP FV N	PA FV N	PP FV N	PA FV N	PP FV N
20	4600	2070	20700	5750	5750	3450
25	6900	2070	20700	5750	6900	3450
30	8050	2300	28750	8050	9200	4600
35	9200	2530	31050	8625	11500	4830
40	9200	2530	31050	8625	11500	4830



UCPA/C - HCPA/C - UCPA - HCPA



Shaft dia. d mm								
	PA FV N	PP FV N	PA FV N	PP FV N	PA FV N	PP FV N	PA FV N	PP FV N
17	2500	1500	8000	3750	1500	1100	1250	1000
20	2500	1700	6750	4300	2300	1200	1100	750
25	3000	1700	10500	5200	2600	1750	1100	900

UCFB/C - HCFB/C - UCFB - HCFB



Shaft dia. d mm				
	PA FV N	PP FV N	PA FV N	PP FV N
20	3000	1700	1000	650
25	3500	2000	1000	650
30	3500	2000	1000	650
35	4000	2500	1000	650
40	5200	3000	1000	650

UCT/C - HCT/C - UCT - HCT





Shaft dia. d mm	
	PA FV N
20	16000
25	24000
30	27000

Bearing unit max. static load



UCFC/C - UCFC



Shaft dia. d mm				
	PA N	FV N	PA N	FV N
35	19550	12650	23000	11500

FC



Shaft dia. d mm						
	PA N	FV N	PA N	FV N	PA N	FV N
35	17250	11500	17250	11500	23000	12650

Bearings

■ Bearings with grub screw locking system

Prelubricated with long lasting lithium/calcium grease • Can be rilubricated

Type A

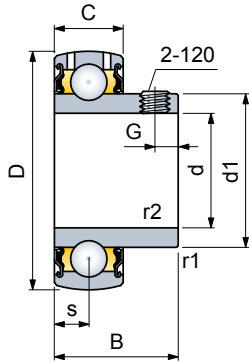

d mm	Dimensions in mm							Load coefficient		Weight Kg	
	d1	D	B	C	s	G	r1, r2 min.	Grub screws	dyn. ¹⁾ C N		stat. Co N
17	24,6	40	22	12	6	4	0,3	M5x0,8	9500	4750	0,07
20	29	47	25	14	7	5	0,6	M6x1	12700	6550	0,11
25	34	52	27	15	7,5	5,5	0,6	M6x1	14000	7800	0,14
30	40,3	62	30	16	8	6	0,6	M6x1	19500	11200	0,23
35	48	72	32	17	8,5	6,5	1	M6x1	25500	15300	0,31
40	53	80	34	18	9	7	1	M8x1	30700	19000	0,43
45	57,2	85	41,2	19	10,2	8,2	1	M8x1	33200	21600	0,48
50	61,8	90	43,5	20	10,9	9,2	1	M8x1	35100	23200	0,54

Chrome alloy steel.

¹⁾ = Values are valid for applications with ≤ h 6 shaft tolerance.

Time 0.77 values must be considered in all other cases.

Type B

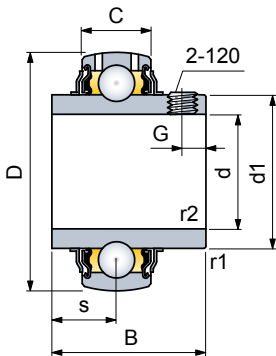

d mm	Dimensions in mm							Load coefficient		Weight Kg	
	d1	D	B	C	s	G	r1, r2 min.	Grub screws	dyn. ¹⁾ C N		stat. Co N
17	24,2	40	27,4	12	11,5	3,5	0,3	M6x0,75	9500	4750	0,09
20	29	47	31	16	12,7	4,7	0,6	M6x1	12700	6550	0,14
25	34	52	34,1	17	14,3	5,5	0,6	M6x1	14000	7800	0,17
30	40,3	62	38,1	19	15,9	5,5	0,6	M6x1	19500	11200	0,28
35	48	72	42,9	20	17,5	6,5	1	M8x1	25500	15300	0,41
40	53	80	49,2	21	19	8	1	M8x1	30700	19000	0,55
45	57,2	85	49,2	22	19	8	1	M8x1	33200	21600	0,60
50	61,8	90	51,6	23	19	9	1	M10x1	35100	23200	0,69

Chrome alloy steel.

¹⁾ = Values are valid for applications with ≤ h 6 shaft tolerance.

Time 0.77 values must be considered in all other cases.

Type C stainless steel

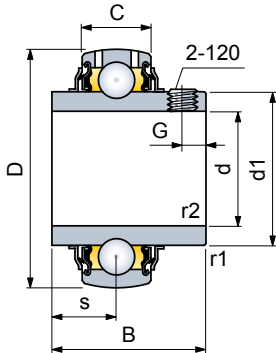

d mm	Dimensions in mm							Load coefficient		Weight Kg	
	d1	D	B	C	s	G	r1, r2 min.	Grub screws	dyn. ¹⁾ C N		stat. Co N
20	29	47	31	17	12,7	5	0,6	M6x1	10800	6550	0,14
25	34	52	34,1	17	14,3	5	0,6	M6x1	11900	7800	0,18
30	40,3	62	38,1	19	15,9	6	0,6	M6x1	16250	11200	0,29
35	48	72	42,9	20	17,5	6	1	M6x1	21600	15300	0,42
40	53	80	49,2	21	19	8	1	M8x1	26000	19000	0,56

Stainless steel AISI 420.

¹⁾ = Values are valid for applications with ≤ h 6 shaft tolerance.

Time 0.77 values must be considered in all other cases.

■ Bearings with self locking eccentric collar

Prelubricated with long lasting lithium/calcium grease • Can be rilubricated • Higher resistance to vibrations • Suitable for single directional travel (cannot reverse the sense of rotation) • Locking of the bearing is achieved by rotating the eccentric collar. The grub screw holds the collar and avoids rotation.

Type D

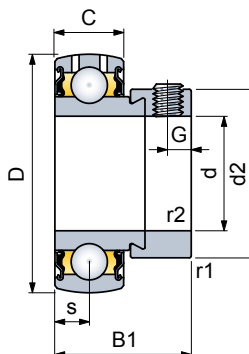

d mm	Dimensions in mm							Load coefficient		Weight Kg	
	d2	D	B1	C	s	G	r1, r2 min.	Grub screws	dyn. ¹⁾ C N		stat. Co N
17	28,6	40	28,6	12	6,5	4,75	0,3	M6x0,75	9500	4750	0,10
20	33,3	47	30,9	14	7,5	5	0,6	M6x1	12700	6550	0,16
25	38,1	52	30,9	15	7,5	5	0,6	M6x1	14000	7800	0,18
30	44,5	62	35,7	16	9	6	0,6	M6x1	19500	11200	0,30
35	51,9	72	38,9	17	9,5	6,5	1	M8x1	25500	15300	0,49
40	60,3	80	43,7	18	11	6,5	1	M8x1	30700	19000	0,62
45	63,5	85	43,7	19	11	6,5	1	M8x1	33200	21600	0,65
50	69,9	90	43,7	20	11	6,5	1	M8x1	35100	23200	0,70

Chrome alloy steel.

¹⁾ = Values are valid for applications with ≤ h 6 shaft tolerance.

Time 0.77 values must be considered in all other cases.

Bearings

Seals

Type A - D. The system consists of a metallic ring fitted with a low friction rubber sealing lip.

Type B. The system is further equipped with a metallic protection ring providing a centrifugal sealing action.

Type C inox. The upper lip of the centrifuging ring together with the grease trapped between the base seal and the ring it self guarantees maximum sealing capacity.

Type A - D

Metal ring with sealing lip



Type B

Centrifuging ring

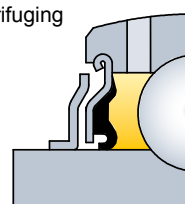

Type C Inox

Rubberised centrifuging ring

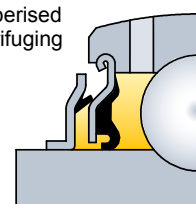

Maximum velocities

The table indicates the values for **A, D, B** series bearings • Stainless steel bearings of the **C** Type (rubberised centrifuging ring) must not be operated at velocities in excess of 60% of the values indicated • The maximum velocity is dependant of the shaft tolerances. Higher tolerances require lower speed

Int. dia. bearing d mm	Shaft tolerance				
	h6	h7	h8	h9	h11
	Speed (RPM)				
17	9500	6000	4300	1500	950
20	8500	5300	3800	1300	850
25	7000	4500	3200	1000	700
30	6300	4000	2800	900	630
35	5300	3400	2200	750	530
40	4800	3000	1900	670	480
45	4300	2600	1700	600	430
50	4000	2400	1600	560	400

Axial load capacities

The bearing locking systems by grub screws/eccentric collars, allow axial loads up to 20% of the dynamic load coefficient (only with non hardened shafts and grub screws tightened as recommended) • For bearings of the **A, D, B, C**, series it is not recommended to exceed the value of: 0,25•C

Self aligning ball bearing holding by shoulders on shaft

The bearings have double row of balls running on a spherical outer race This configuration renders the bearing self aligning • The bearings are supplied without sealing units • They are held into position by shoulders on the shaft.

Type 1200

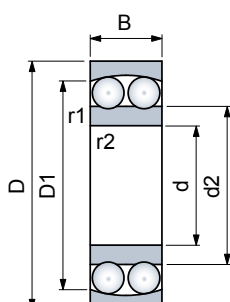

d mm	Bearing type	Dimensions in mm					Load coefficient		Revolutions RPM	Weight Kg
		D	B	d2	D1	r1, r2 min.	dyn. C N	stat. Co N		
20	1204	47	14	28,9	41	1	12700	3400	15000	0,12
25	1205	52	15	33,3	45,6	1	14300	4000	13000	0,14
30	1206	62	16	40,1	53	1	15600	4650	10000	0,22
35	1207	72	17	47	62,3	1,1	19000	6000	9000	0,32
40	1208	80	18	53,6	68,8	1,1	19900	6950	8500	0,42

Calculation data

■ Bearing dimensioning

The bearing dimensions, for a given application, should be chosen on the basis of the loads to be supported, expected service life and reliability. In most cases the reason for choosing a bearing is the fact that the shaft has already been sized during the design of the plant.

■ Calculation procedures for self-aligning bearings

The calculation procedure for self-aligning bearings consists in ensuring a satisfactory operating life of the unit:

- 1) The nominal service life is calculated using the formulas indicated below, keeping in mind the type of stress on the bearing (dynamic or static).
- 2) The nominal life of the bearing should reflect the expected service life of the plant as indicated in Table 1 hereunder.

■ Service life

The dimensioning of the bearing requires the knowledge of the appropriate life expectancy of the project in relation to the specific application. This depends on the type of plant, daily/yearly working hours and on the required reliability. In the absence of practical experience Table 1 gives our recommendations of the average expected plant life under various conditions.

Table 1 - Recommended plant expected life L_{10h} for MB support bearings

Plant type	Plant expected life L_{10h} hours
Seasonal Operation plants	4000 ÷ 8000
Daily operated plant, 8 hours/day, not completely utilised	10000 ÷ 20000
Daily operated plant, 8 hours/day, completely utilised	20000 ÷ 30000
Daily operated plant, 24 hours/day	40000 ÷ 80000

Dynamically stressed bearings

Bearings which rotate under load are considered dynamically stressed (one ring of the bearing makes one full rotation against the other). In most cases, self-aligning supports are dynamically stressed.

■ Expected life calculation formula

The service life of a bearing is expressed in the number of revolutions or hours of operations which can be expected without breakdown (erosion or laminations of the bearing revolving parts).

The calculating procedure for nominal duration is valid whatever the type of bearing:

$$L_{10} = \left(\frac{C}{P}\right)^3 \text{ Life in Millions revolutions.}$$

When bearings rotate at constant speed it is more practical to calculate the life in number of hours:

$$L_{10h} = \frac{16666}{n} \cdot \left(\frac{C}{P}\right)^3 \text{ Life in hours.}$$

L_{10} = life in millions of revolutions.

L_{10h} = life in hours.

C = dynamic load coefficient (N). Values are indicated in the support dimensional tables.

P = equivalent dynamic load (N). See calculation formula on Table 2.

n = revolutions (RPM).

■ Correct expected life

In the majority of cases, for self aligning MB bearings, it is sufficient to calculate L_{10} , L_{10h} using the formula indicated above. The new theory of life calculation permits to establish the correct life expectancy keeping into consideration the effects of lubrication, pollution of solid particles and of the fatigue limit load P_u (values are reported in the bearing tables). The calculation of the correct expected life requires therefore the assistance of the technical commercial staff.

Calculation data

Equivalent dynamic load P calculation

Table 2 - Equivalent dynamic load P calculation

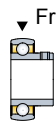
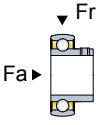
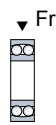
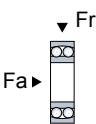
Bearing Type	Load direction on the bearing	Equivalent dynamic load P (N) calculation formula
A B C D		$P = Fr$
		$P = X \cdot Fr + Y \cdot Fa$
1200		$P = Fr$
		$P = Fr + Y1 \cdot Fa$ with $\frac{Fa}{Fr} \leq e1$ $P = 0,65 \cdot Fr + Y2 \cdot Fa$ with $\frac{Fa}{Fr} > e1$

- P** = equivalent dynamic load (N).
- Fr** = radial load acting on the bearing (N).
- Fa** = axial load acting on the bearing (N).
- x, Y** = load factors. See Table 3.
- e1, Y1, Y2** = factors. See Table 4.

Table 3 - Load factors x, y

Ratio $\frac{Fa}{Co}$	e	With: $\frac{Fa}{Fr} \leq e$		With: $\frac{Fa}{Fr} > e$	
		x	y	x	y
0,025	0,22	1	0	0,56	2
0,04	0,24	1	0	0,56	1,8
0,07	0,27	1	0	0,56	1,6
0,13	0,31	1	0	0,56	1,4
0,25	0,37	1	0	0,56	1,2
0,5	0,44	1	0	0,56	1

Table 4 - Factors e1, Y1, Y2, Yo

Int. dia. bearing mm	e1	Y1	Y2	Yo
20	0,30	2,1	3,3	2,2
25	0,28	2,2	3,5	2,5
30	0,25	2,5	3,9	2,5
35	0,23	2,7	4,2	2,8
40	0,22	2,9	4,5	2,8

Co = Static load coefficient (N).
The values are indicated in the support dimensional tables.

Operating conditions coefficients

It should be common practice to include operational factors when calculating bearing dimensions to allow for load variations which may happen during running of the plant. The coefficients given here under are indicative only and are based on actual operational experience.

- With steady loads/light impacts: multiply the equivalent dynamic load P by: 1,2 ÷ 1,5
- With loads and medium impacts: multiply the equivalent dynamic load P by: 1,7 ÷ 2,0

Calculation data

Static load capacity control

Statically stressed bearings

In rolling-contact bearing technology the condition of static load is considered to exist when:

- The bearing does not rotate and is subjected to permanent loads or intermittent ones (impacts).
- The bearing is subjected to loads and slow oscillating movements.
- The bearing rotates under load at a very low speed and for short periods.
- The bearing rotates under load and must withstand strong impacts acting in the course of one revolution.

The static safety coefficient f_s must not exceed the recommended values given in Table 5 in order to obtain a satisfactory performance of the bearings. Coefficient f_s gives the safety margin against excessive permanent deformation of the revolving parts of the bearing.

$$f_s = \frac{C_o}{P_o}$$

f_s = static safety coefficient.
 C_o = static load coefficient (N). The values are given in the support dimensional tables.
 P_o = equivalent static load (N). See calculation formula given below.

Table 5 - Static safety coefficient f_s for MB bearings

Type of operation	Revolving bearings			Non revolving bearings
	Noise level not important	Normal noise level operation	Low noise level operation	
Smooth operation without vibration	5	1	2	0,4
Normal operation	0,5	1	2	0,5
Impact loads operation	$\geq 1,5$	$\geq 1,5$	≥ 2	≥ 1

Equivalent static load P_o calculation

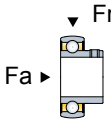
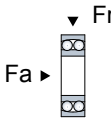
Bearing type	Load direction on the bearing	Equivalent dynamic load P (N) calculation formula
A B C D		$P_o = 0,6 \cdot Fr + 0,5 \cdot Fa$ If $P_o < Fr$, then assume $P_o = Fr$.
1200		$P_o = Fr + Y_o \cdot Fa$

P_o = equivalent static load (N).
 Fr = radial load on the bearing (N).
 Fa = axial load on the bearing (N).
 Y_o = see table 4.

Lubrication

■ Prelubrication

All self-aligning bearings are supplied factory lubricated.

Warning

The first lubrication must be carried out only for bearings of the series FL - F - FC held by the shaft shoulders.

■ Lubricating grease

Bearings are prelubricated with long lasting lithium/calcium grease.

Technical data	NLGI consistency:	2
	Emulsifier:	lithium/calcium
	Base oil:	mineral
	Base oil viscosity:	165 mm ² /s at 40°C
	Operating temperature:	- 20°C to +120°C
	Water resistance:	Recommended
	Antioxidant properties:	Recommended

■ Relubrication

All self-aligning bearing units are equipped with a grease nipple of the ball type to allow periodical relubrication of the bearing.

Warning

- Do not grease at first assembly.
- The first lubrication must be carried out only for bearings of the series FL - F - FC held by the shaft shoulders.
- Stainless steel pressed metal supports of the series SBF are not relubricatable.
- Use only grease of same characteristics as indicated.
- Clean greasing nipple before each greasing operation.
- Inject grease slowly until it comes out from the bearing.
Keep the bearing rotating and do not apply excessive pressure which could damage the sealing units.
- More frequent greasing operations with smaller quantities of grease are to be preferred.

■ Relubrication intervals

Relubrication intervals vary according to actual operating conditions. Very often during operation, load, speed, temperature and ambient conditions (humidity, dust) may vary making it difficult to establish exact rules. Experience once again gives the best answer:

- Light operating conditions: relubricate every 6 months.
- Normal operating conditions: relubricate every 1÷3 months.
- Heavy operating conditions: relubricate every 2 weeks.

Grease life in bearings lubricated for life

(dry use recommended)

■ **Formula to calculate grease life in bearings lubricated for life**

This procedure allows to calculate the grease life as a function of its quality and bearing type, dimension, rotating speed, applied loads and working temperature.

$$L_h = L_{10} \times F_c \text{ Grease life (hours)}$$

- L_h = Grease life (hours).
- L_{10h} = Grease nominal life (hours). See Diagram 1.
- F_c = Correction factor. See Diagram 2.

■ **Diagram 1**

- Grease nominal life L_{10h}

This diagram allows to determine the nominal grease life L_{10h} (hours), as a function of rotating speed n (rpm), mean diameter dm (mm), bearing working temperature ($^{\circ}C$). Greases are classified by a factor GPF (Grease Performance Factor), related to their temperature performance. In this table we consider a grease with GPF = 1, which is the grease used in all Marbett LifeLube bearings.

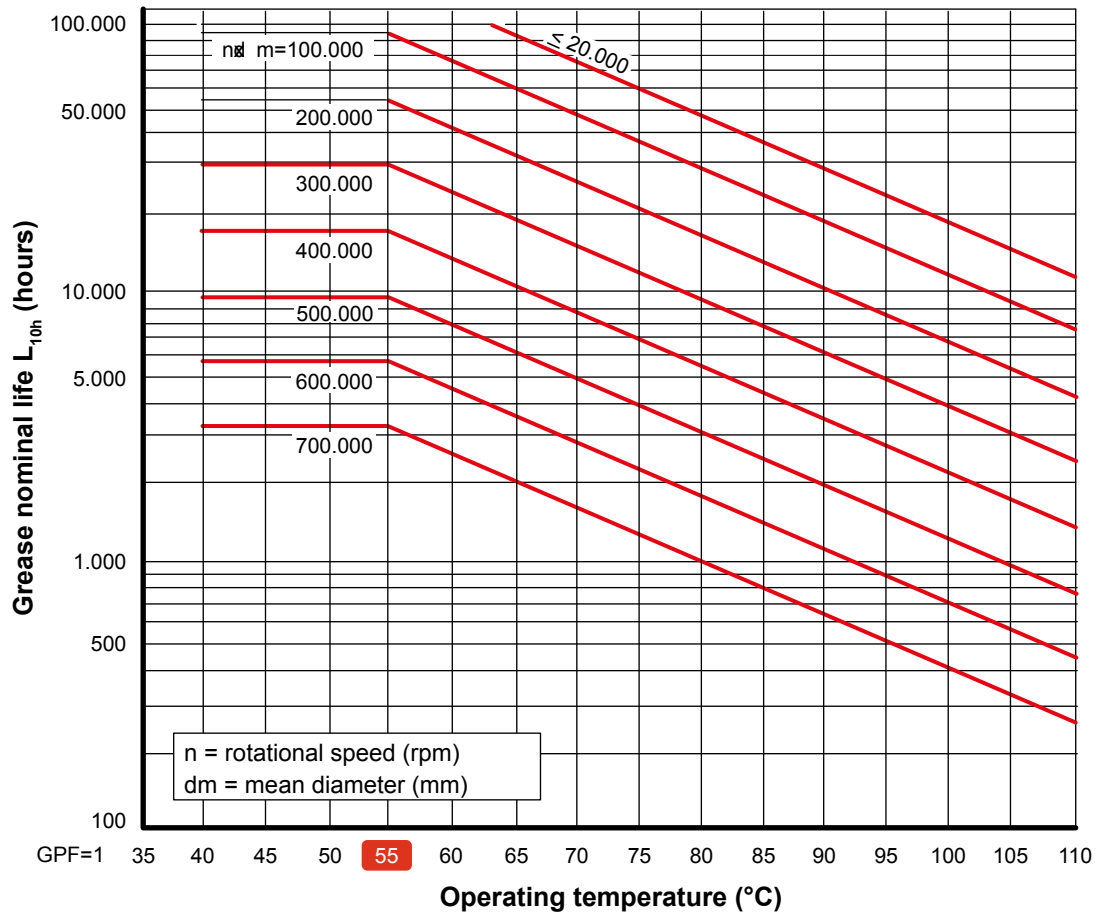

dm (mm) = mean diameter.

Type A

Type D

dia. d mm	dia. dm mm
17	28,5
20	33,5
25	38,5
30	46
35	53,5
40	60
45	65
50	70

55 = At room temperature, with normal working conditions, the grease works at a temperature lower than 55°C.

Grease life in bearings lubricated for life

(dry use recommended)

■ **Diagram 2 - Correction factor Fc**

The corrective factor Fc, keeps into consideration the influence of load applied on bearings as a function of load ratio C/P. With low loads (C/P ≥ 15) the duration of the grease is not influenced by load values.

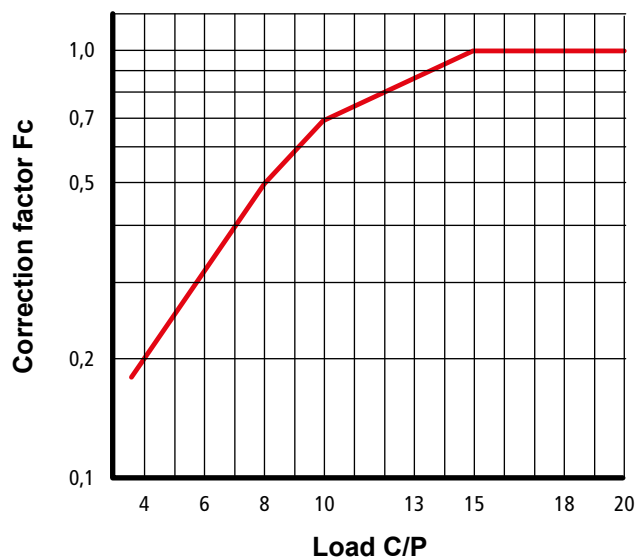

C = Dynamic load coefficient (N).
Values are indicated in the bearings dimensional tables.
P = Equivalent dynamic load (N).
See Table 2.

■ **Example of calculation**

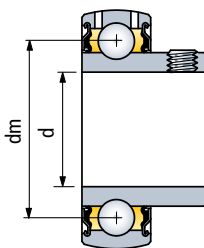

- Data:
- Bearing Type **A**.
 - $d = 40$ mm (shaft dia.).
 - $dm = 60$ mm. (bearing mean dia.).
 - $n = 300$ rpm. (rotational speed).
 - 55 °C (grease operating temperature).
 - $C = 23600$ N (Dynamic load coefficient).
 - $P = 3000$ N (equivalent dynamic load).
- From Diagram 1, as a function of:
 $n \times dm = 300 \text{ rpm} \times 60 \text{ mm} = 18000$
we read a nominal grease life of:
 $L_{10h} = 100000$ hours.
 - From Diagram 2, as a function of:
 $C/P = 23600 \text{ N} : 3000 \text{ N} = 7,8$
we read a corrective factor of:
 $F_c = 0,5$.
 - Calculation of estimated grease life:
 $L_h = L_{10h} \times F_c = 100000 \text{ hours} \times 0,5 = 50000$ hours.

Shaft tolerances

Tolerances for grub screws/ eccentric collar locked bearings

- The tables indicate shaft diameter tolerances.
- Shaft ends must be rounded off in order to:
 - ease assembly and avoid bearing jamming.
 - avoid damages to the rubber parts of the sealing units.
- The shaft surface for the portion in contact with the sealing gaskets must be smooth and free of defects (scratches etc.).

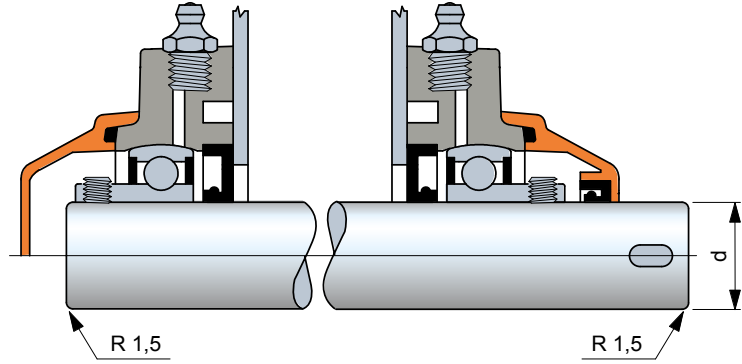

ISO shaft tolerance

Shaft dia. d mm	Heavy loads High speed		Normal operation		Light loads Low speed		Simple applications					
	h 6		h 7		h 8		h 9		h 10		h 11	
	plus	min.	plus	min.	plus	min.	plus	min.	plus	min.	plus	min.
17	0	-11	0	-18	0	-27	0	-43	0	-70	0	-110
20 ÷ 30	0	-13	0	-21	0	-33	0	-52	0	-84	0	-130
35 ÷ 50	0	-16	0	-25	0	-39	0	-62	0	-100	0	-160

Tolerances in μm

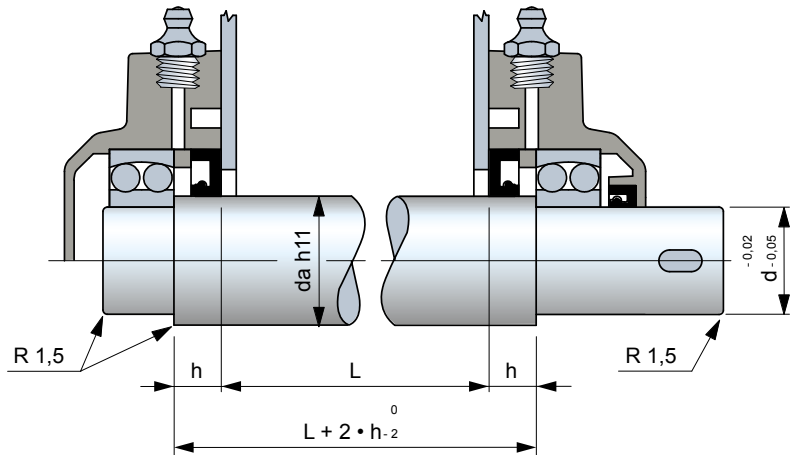

h values are given in the support dimensional tables

Tolerances for shaft shoulders locked bearings

- Shaft ends must be rounded off in order to:
 - ease assembly and avoid bearing jamming.
 - avoid damages to the rubber parts of the sealing units.
- The shaft surface for the portion in contact with the sealing gaskets must be smooth and free of defects (scratches etc.).
- The mounting shaft/bearing is free to facilitate assembly. For heavy radial loads conditions it is recommended a slightly tight mounting.

Mounting

■ Assembly instructions

1 - With waterproof bearings the rubber sealing units must be greased before mounting to avoid initial dry running on the shaft. The grease must fill only the space in between the two sealing lips.

2 - The bearing must be locked onto the shaft after the support mounting flange has been fully tightened. This is necessary to allow the bearing to assume its correct alignment on the shaft without undue axial stresses. Always tighten the screws diagonally.



■ Locking of the bearing by grub screws

3 - The table gives the recommended maximum tightening couples for the grub screws and the size of the hexagonal to use.



Int. dia. bearing mm	Sc. driver size mm			Max. tightening couple Nm		
	Bearings A C		Bearings D	Bearings A C		Bearings D
	A	A C	D	A	A C	D
17	2,5	3	3	3,5	4	4
20	3	3	3	4	4	4
25	3	3	3	4	4	4
30	3	3	3	4	4	4
35	3	4	4	4	6,5	6,5
40	4	4	4	6,5	6,5	6,5
45	4	4	4	6,5	6,5	6,5
50	4	5	4	6,5	16,5	6,5

■ Locking of the bearings by eccentric collar

4 - Tighten the collar by turning it with a punch in the same direction as the rotation of the shaft.

5 - Hand tighten the grub screw. The screw driver dimension and the tightening couple are given in the table above (Ref. D series bearings).



■ Assembly / removal of the protection cover

6 - Assembly. The sealing unit of open end covers must be greased to avoid initial dry running on the shaft. The grease must fill only the space in between the two sealing lips.

7 - Removal. Insert a screw driver into the groove provided for and force the cover out.



Resistance against chemical agents	POLYAMIDE PA	POLYPROPYLENE PP	POLYETHYLENE PE	ACETAL POM	AISI 303 AISI 304	AISI 316	NICKEL PLATED BRASS	NBR RUBBER	VITON RUBBER
	Conc.% 23°C	Conc.% 23°C	Conc.% 23°C	Conc.% 23°C	Conc.% 23°C	Conc.% 23°C	Conc.% 23°C	Conc.% 23°C	Conc.% 23°C
PHENOL	-	+			10 +	+		-	+
PHOSFORIC ACID	10 -	85 +	95 +	10 -	10 -	50 /	-	20 /	85 +
POTASSIUM HYDROXIDE	10 +				50 +	50 +		/	+
SEA WATER	+	+	+	/	+	+	+	+	+
SILICONE OIL	+	+						+	+
SILVER NITRATE	+	20 +			60 /			/	+
SOAP AND WATER	+	+	+	+	+			+	
SODIUM CARBONATE	10 +	Sat. +	+	+	5 +	100 +		+	+
SODIUM CHLORIDE	10 +	Sat. +	+	+	5 +	/	+	+	Sat. +
SODIUM HYDROXIDE	10 +	30 +	+	10 +	-		+	/	
SODIUM HYPOCHLORITE	+	20 +	+	-	-			-	5 +
SODIUM SILICATE	+				100 +	100 +		+	
SODIUM SULPHATE	10 +	Sat. +	+	+	5 +	100 +		+	+
SOFT DRINKS	+	+	+	+	+		+	+	
SUDS	+	+						+	+
SULPHURIC ACID	10 -	98 +	40 /	40 -	10 -	100 +	+	-	95 +
TARTARIC ACID	+	10 +	+	30 /	10 +	50 +	-	+	+
TETRALINE	+	-						-	+
TINCTURE OF IODINE	-	+	+	+			-	/	
TRANSFORMER OIL	+	/						+	+
TRICHLORETHYLENE	/	/	+	-	+		+	-	+
TURPENTINE	/	-	-	-	+			-	
VASELINE	+	+	/	+				+	+
VEGETABLE JUICES	+	+	+	+	+			+	
VEGETABLE OILS	+	+	+	+	+			+	
VINEGAR	+	+	+	+	+		+	/	-
WHISKY	+	+	+	+	+		+	+	+
WINE	+	+	+	+	+		+	+	+
XILOL	+	-	/	+	+		/	-	+
ZINC CHLORIDE	10 /	20 +			10 -	/		+	Sat. +

Abbreviations: Sat. = saturated.

Legend..

- + = Good resistance.
- / = Fairly good resistance (limited use depending on working conditions).
- = Poor resistance (not recommended).
- N.B. Where tests have not been carried out the spaces are left blank.

The data shown in this table..

are taken from laboratory tests, performed on unstrained test samples. It should be considered as purely indicative since material behaviour under real working conditions depends on different factors: temperature, concentration of the chemical agent, quick or long-lasting effect of the chemical agent.

Operating temperatures

Operating temperatures (°C)

Material	Description	contact with air		contact with hot water
		Min	Max	Max
PA	Polyamid	0	+ 80	+ 65
PA FV	Reinforced polyamid	- 5	+ 120	+ 100
PP	Polypropylene	+ 5	+ 105	+ 105
PP FV	Reinforced polypropylene	+ 5	+ 115	+ 115
PE (UHMWPE)	Polyethylene	- 40	+ 80	+ 70
POM	Acetal	- 40	+ 80	+ 65
Rex-LF®	Acetal	- 40	+ 80	+ 65
AISI 303 - AISI 304	Austenitic stainless steel (18/8)	- 70	+ 430	+ 120
Fe Zn	Zinc plated steel	- 40	+ 180	-
OT	Nickel plated brass	- 40	+ 180	+ 120

	Page.		Page.		Page.		Page.
Part. S0000	S109	Part. S0275	S025	Part. S0580	S064	Part. S0766	S022
Part. S0050	S098	Part. S0275	S087	Part. S0581	S060	Part. S0767	S020
Part. S0061	S110	Part. S0280	S125	Part. S0581	S061	Part. S0767	S052
Part. S0063	S083	Part. S0296	S058	Part. S0594	S045	Part. S0768	S020
Part. S0070	S096	Part. S0298	S101	Part. S0599	S103	Part. S0768	S052
Part. S0071	S096	Part. S0303	S143	Part. S0611	S127	Part. S0770	S051
Part. S0073	S028	Part. S0308	S046	Part. S0612	S152-S153	Part. S0771	S043
Part. S0075	S154	Part. S0317	S048	Part. S0613	S033	Part. S0782	S030
Part. S0082P	S094	Part. S0337	S140	Part. S0614	S033	Part. S0784	S007
Part. S0107	S103	Part. S0338	S113	Part. S0615	S126	Part. S0786	S121
Part. S0126	S028	Part. S0339	S120	Part. S0616	S129	Part. S0787	S030
Part. S0128	S082-S083	Part. S0340	S118	Part. S0617	S104	Part. S0814	S010
Part. S0137	S132	Part. S0341	S136	Part. S0618	S127	Part. S0822	S004
Part. S0140	S104	Part. S0342	S136	Part. S0619	S128	Part. S0825	S004
Part. S0153	S027	Part. S0346	S050	Part. S0632	S105	Part. S0826	S031
Part. S0159	S095	Part. S0356	S021	Part. S0634	S010	Part. S0827	S031
Part. S0174	S118	Part. S0362	S007	Part. S0637	S106	Part. S0837	S156
Part. S0182	S144	Part. S0366	S014	Part. S0642	S056	Part. S0840	S006
Part. S0183	S144	Part. S0367	S014	Part. S0643	S056	Part. S0846	S148
Part. S0184	S100	Part. S0368	S015	Part. S0645	S057	Part. S0847	S148
Part. S0185	S145	Part. S0369	S012	Part. S0654	S045	Part. S0848	S148
Part. S0190	S100	Part. S0369	S054	Part. S0657	S035	Part. S0849	S148
Part. S0191	S058	Part. S0371	S017	Part. S0661	S116	Part. S0850-S0865	S148
Part. S0192	S108	Part. S0372	S138	Part. S0662	S097	Part. S0852	S081
Part. S0198	S124	Part. S0378	S059	Part. S0672	S146	Part. S0854	S081
Part. S0199	S122	Part. S0387	S008	Part. S0674	S011	Part. S0856	S078
Part. S0210P	S086	Part. S0393	S047	Part. S0685	S135	Part. S0857	S079
Part. S0211	S087	Part. S0421	S029	Part. S0686	S134	Part. S0858	S016
Part. S0213	S088	Part. S0422	S054	Part. S0692	S114	Part. S0862	S107
Part. S0213	S088	Part. S0518	S139	Part. S0694	S090	Part. S0864	S148
Part. S0215	S025	Part. S0523	S037	Part. S0698	S097	Part. S0868	S070
Part. S0215	S091	Part. S0523	S037	Part. S0699	S115	Part. S0868	S072
Part. S0217	S090	Part. S0524	S036	Part. S0708	S102	Part. S0869	S071
Part. S0218	S085	Part. S0533	S039	Part. S0715	S043	Part. S0869	S073
Part. S0219	S049	Part. S0535	S065	Part. S0725	S111	Part. S0885	S013
Part. S0223	S023	Part. S0537	S065	Part. S0729	S036	Part. S0885	S015
Part. S0223	S048	Part. S0539	S057	Part. S0732	S116	Part. S0902	S024
Part. S0226	S112	Part. S0550	S018	Part. S0736	S089	Part. S0903	S024
Part. S0237	S092	Part. S0554	S032	Part. S0737	S089	Part. S0903	S091
Part. S0241	S003	Part. S0555	S034	Part. S0754	S075	Part. S0905	S150-S151
Part. S0243	S003	Part. S0556	S032	Part. S0755	S067	Part. R0098	R10-R11
Part. S0244	S006	Part. S0557	S062	Part. S0755	S069	Part. R0133	R14-R15
Part. S0247	S049	Part. S0562	S130	Part. S0756	S074	Part. R0134	R20
Part. S0247	S092	Part. S0563	S130	Part. S0756	S076	Part. R0173	R08-R09
Part. S0251	S005	Part. S0564	S131	Part. S0757	S066	Part. R0180	R40
Part. S0256	S107	Part. S0565	S042	Part. S0757	S068	Part. R0224	R41
Part. S0260	S140	Part. S0567	S146	Part. S0758	S034	Part. R0297	R21
Part. S0261	S005	Part. S0568	S147	Part. S0760	S080	Part. R0323	R12-R13
Part. S0262	S002	Part. S0569	S147	Part. S0763	S117	Part. R0349	R34
Part. S0272	S142	Part. S0570	S063	Part. S0765	S021	Part. R0406	R39
Part. S0273	S053	Part. S0580	S062	Part. S0765	S053	Part. R0408	R35

	Page.		Page.
Part. R0479	R16-R17	Part. UCF/C	B04
Part. R0622	R26-R27	Part. UCF/CL	B06
Part. R0623	R28-R29	Part. UCFB	B30
Part. R0626	R22-R23	Part. UCFB/C	B28
Part. R0627	R23-R25	Part. UCFC	B40
Part. R0628	R30-R31	Part. UCFC/C	B38
Part. R0629	R32-R33	Part. UCFL	B20
Part. R0747	R36	Part. UCFL/C	B18
Part. R0747F	R37	Part. UCFLN	B16
Part. R0748	R36	Part. UCFLN/C	B14
Part. R0748F	R37	Part. UCFS/C	B10
Part. R0749	R36	Part. UCP	B24
Part. R0750S	R38	Part. UCP/C	B22
Part. R0750SF	R38	Part. UCPA/C	B26
Part. R0869	R18-R19	Part. UCT/C	B36
Part. F	B12		
Part. HCF	B08		
Part. HCF/C	B04		
Part. HCF/CL	B06		
Part. HCFB	B30		
Part. HCFB/C	B28		
Part. HCFL	B20		
Part. HCFL/C	B18		
Part. HCFLN	B16		
Part. HCFLN/C	B14		
Part. HCFS/C	B10		
Part. HCP	B24		
Part. HCP/C	B22		
Part. HCPA/C	B26		
Part. HCT/C	B36		
Part. SBF	B42		
Part. SF	B12		
Part. SHCF	B08		
Part. SHCF/C	B04		
Part. SHCF/CL	B06		
Part. SHCFL	B20		
Part. SHCFL/C	B18		
Part. SHCFLN	B16		
Part. SHCFLN/C	B14		
Part. SHCFS/C	B10		
Part. SQL	B34		
Part. SQL/C	B32		
Part. SUCF	B08		
Part. SUCF/C	B04		
Part. SUCF/CL	B06		
Part. SUCFL	B20		
Part. SUCFL/C	B18		
Part. SUCFLN	B16		
Part. SUCFLN/C	B14		
Part. SUCFS/C	B10		
Part. UCF	B08		

Why Choose Rexnord?

When it comes to providing highly engineered products that improve productivity and efficiency for industrial applications worldwide, Rexnord is the most reliable in the industry. Commitment to customer satisfaction and superior value extend across every business function.

Delivering Lowest Total Cost of Ownership

The highest quality products are designed to help prevent equipment downtime and increase productivity and dependable operation.

Valuable Expertise

An extensive product offering is accompanied by global sales specialists, customer service and maintenance support teams, available anytime.

Solutions to Enhance Ease of Doing Business

Commitment to operational excellence ensures the right products at the right place at the right time.

REXNORD

Rexnord Company Overview

Rexnord is a growth-oriented, multi-platform industrial company with leading market shares and highly trusted brands that serve a diverse array of global end markets.

Process & Motion Control

The Rexnord Process & Motion Control platform designs, manufactures, markets and services specified, highly engineered mechanical components used within complex systems where our customers' reliability requirements and the cost of failure or downtime are extremely high.

Water Management

The Rexnord Water Management platform designs, procures, manufactures and markets products that provide and enhance water quality, safety, flow control and conservation.